



This is a digital copy of a book that was preserved for generations on library shelves before it was carefully scanned by Google as part of a project to make the world's books discoverable online.

It has survived long enough for the copyright to expire and the book to enter the public domain. A public domain book is one that was never subject to copyright or whose legal copyright term has expired. Whether a book is in the public domain may vary country to country. Public domain books are our gateways to the past, representing a wealth of history, culture and knowledge that's often difficult to discover.

Marks, notations and other marginalia present in the original volume will appear in this file - a reminder of this book's long journey from the publisher to a library and finally to you.

Usage guidelines

Google is proud to partner with libraries to digitize public domain materials and make them widely accessible. Public domain books belong to the public and we are merely their custodians. Nevertheless, this work is expensive, so in order to keep providing this resource, we have taken steps to prevent abuse by commercial parties, including placing technical restrictions on automated querying.

We also ask that you:

- + *Make non-commercial use of the files* We designed Google Book Search for use by individuals, and we request that you use these files for personal, non-commercial purposes.
- + *Refrain from automated querying* Do not send automated queries of any sort to Google's system: If you are conducting research on machine translation, optical character recognition or other areas where access to a large amount of text is helpful, please contact us. We encourage the use of public domain materials for these purposes and may be able to help.
- + *Maintain attribution* The Google "watermark" you see on each file is essential for informing people about this project and helping them find additional materials through Google Book Search. Please do not remove it.
- + *Keep it legal* Whatever your use, remember that you are responsible for ensuring that what you are doing is legal. Do not assume that just because we believe a book is in the public domain for users in the United States, that the work is also in the public domain for users in other countries. Whether a book is still in copyright varies from country to country, and we can't offer guidance on whether any specific use of any specific book is allowed. Please do not assume that a book's appearance in Google Book Search means it can be used in any manner anywhere in the world. Copyright infringement liability can be quite severe.

About Google Book Search

Google's mission is to organize the world's information and to make it universally accessible and useful. Google Book Search helps readers discover the world's books while helping authors and publishers reach new audiences. You can search through the full text of this book on the web at <http://books.google.com/>

NEDL TRANSFER



HN 3R15 7



Age 633.11

7-0-00-00

(KF373)

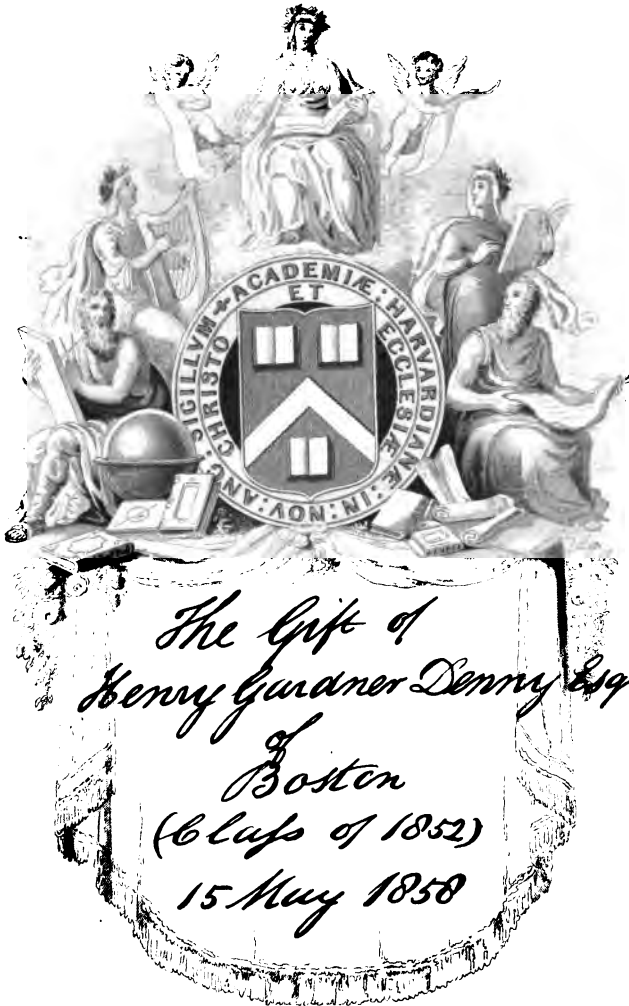



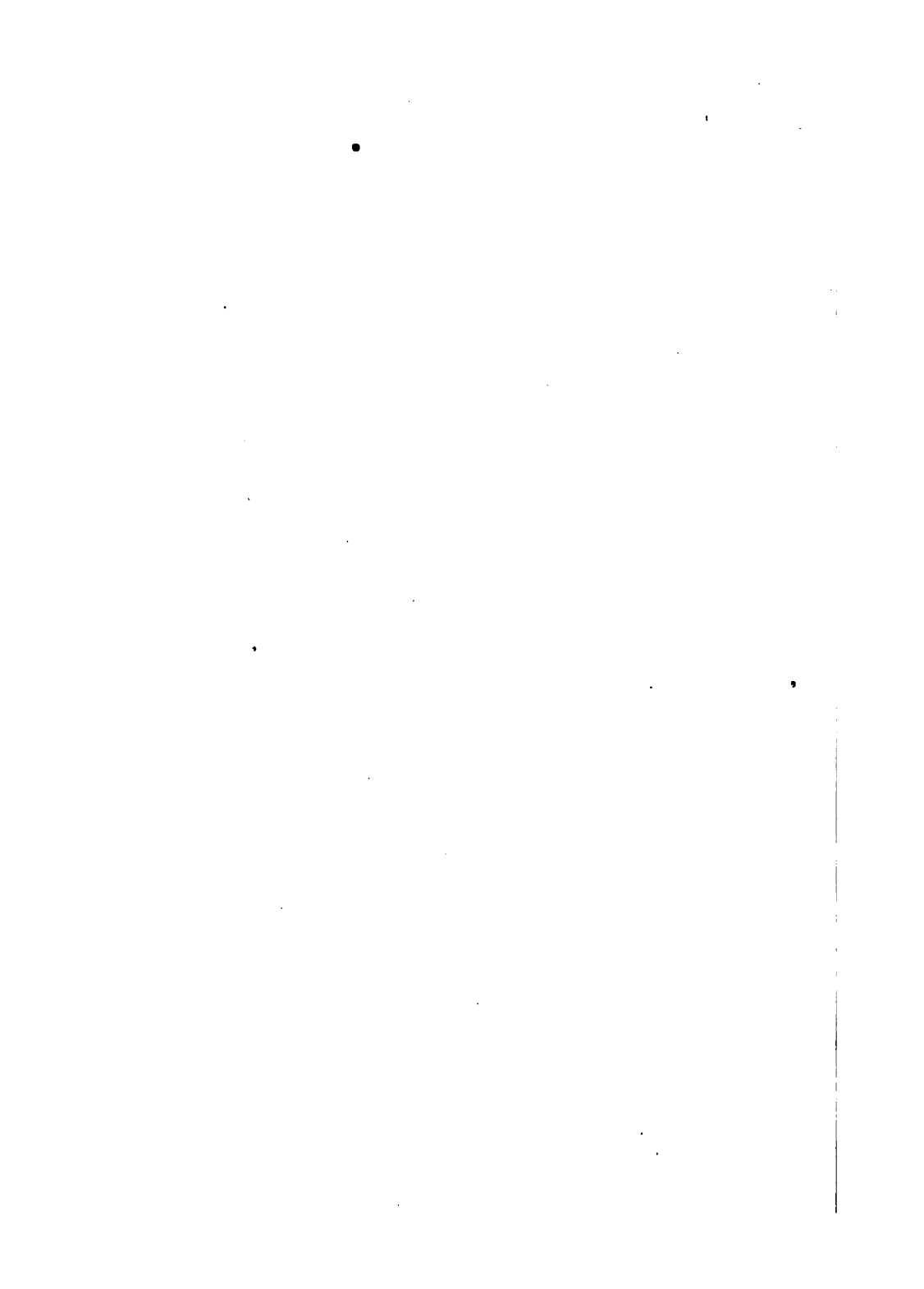

A. O. Love

Reading,

Reading,

Mass.

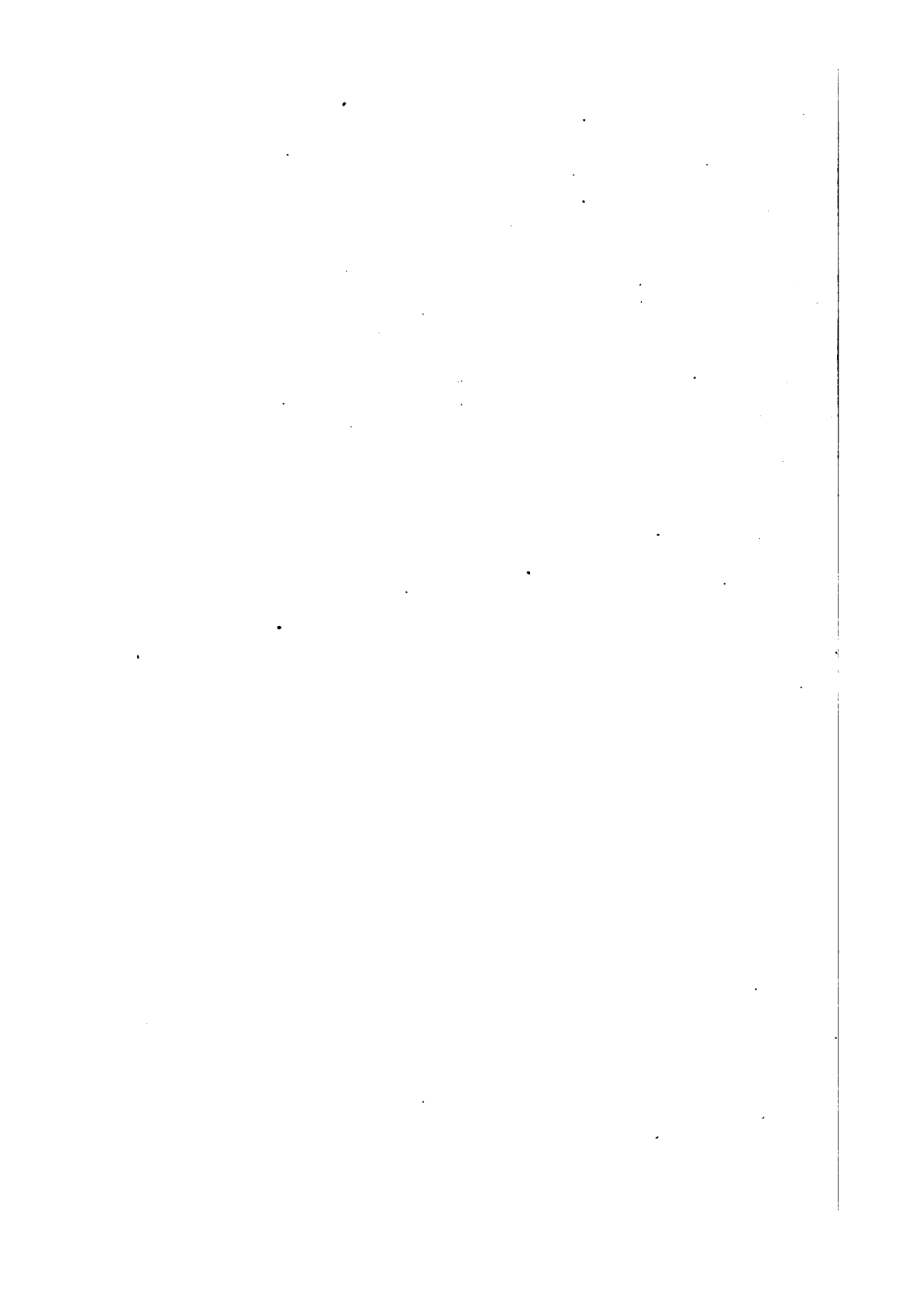

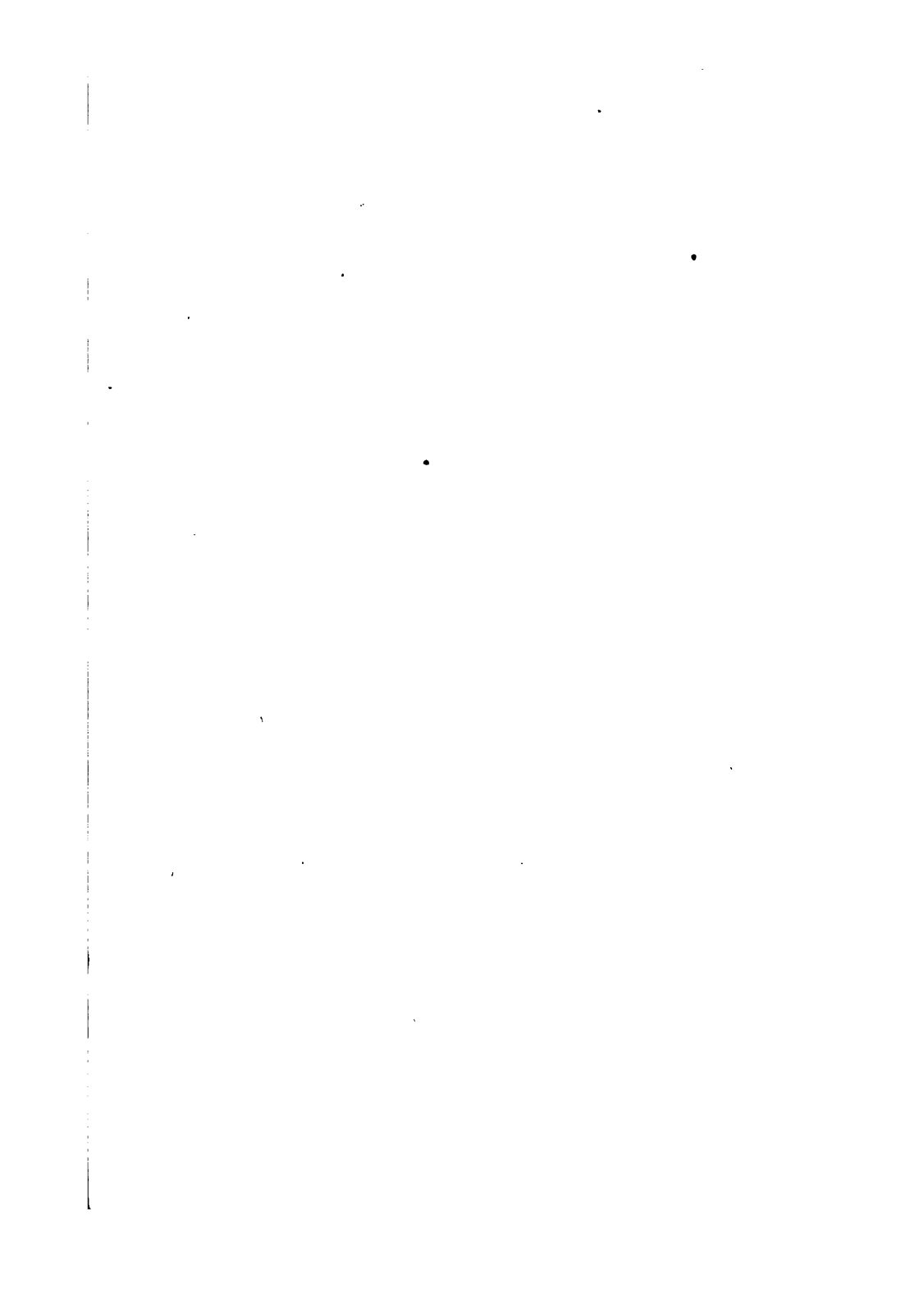

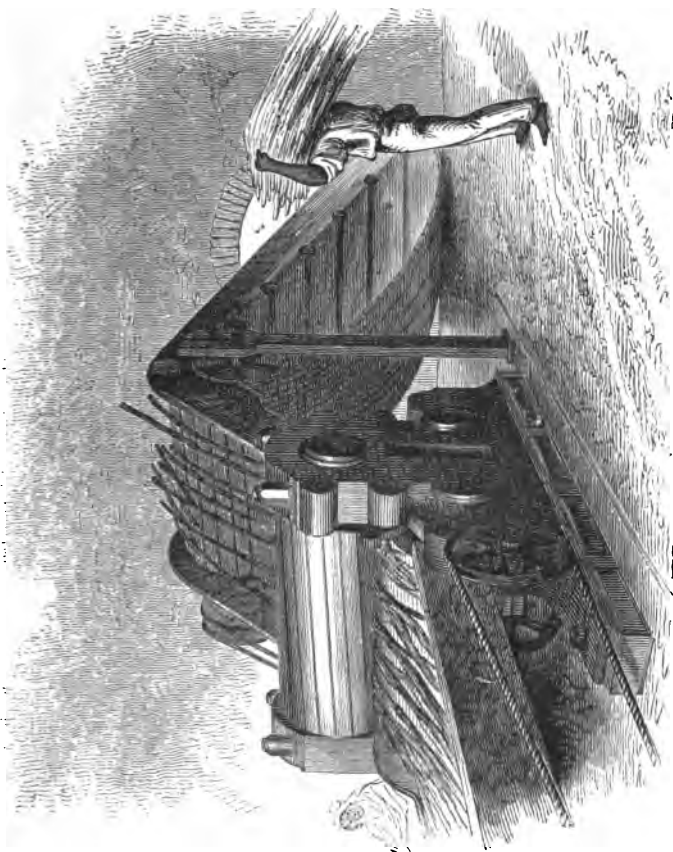

THREE ROLLER HORIZONTAL CANE MILL.

SORGHO AND IMPHEE,

THE

NOTICE.

THE PUBLISHER would announce, that owing to the unusual backwardness of the present season, the crops of sorgho and imphee, even at the South, are not in a sufficiently advanced state to admit of obtaining in time for the first edition of this work, the results of the experiments of 1857.

To delay, even for one week, the publication of the work, would be to deprive a large number of those whose crops are now ripening, of the valuable instructions and suggestions contained in the book, at the time they most need them.

The Author, Mr. H. S. Olcott, is now engaged in visiting the extensive plantations of Governor Hammond of South Carolina, and Richard Peters, Esq. of Georgia, and finds there the highest satisfaction with the appearance of the crop, which is nearly ready for the mill, and the greatest enthusiasm every where prevails as to the value of these *new Sugar Canes*.

As soon as the results of the experiments for the present year are satisfactorily known, a full account will be published in circular form, and transmitted, post paid, to all purchasers of the book, who will send us their names and post office address.

New York, August 28th, 1857.

A. O. MOORE,

AGRICULTURAL BOOK PUBLISHER,

140 Fulton Street, New York.

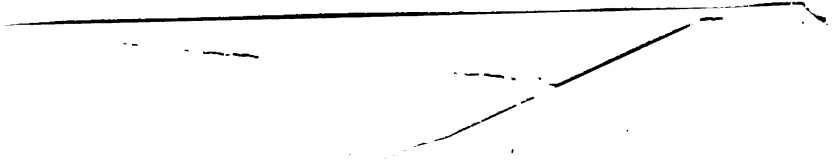

SORGHO AND IMPHEE,

THE

CHINESE AND AFRICAN SUGAR CANES.

A TREATISE UPON THEIR

ORIGIN, VARIETIES AND CULTURE;

THEIR VALUE AS A FORAGE CROP; AND THE MANUFACTURE OF SUGAR,
SYRUP, ALCOHOL, WINES, BEER, CIDER, VINEGAR, STARCH AND DYE-
STUFFS; WITH A PAPER BY LEONARD WRAY, ESQ., OF
CAFFRARIA, AND A DESCRIPTION OF HIS PATENTED
PROCESS FOR CRYSTALLIZING THE
JUICE OF THE IMPHEE.

TO WHICH ARE ADDED,

COPIOUS TRANSLATIONS OF VALUABLE FRENCH PAMPHLETS.

BY HENRY S. OLCOTT.

Fully Illustrated with Drawings of the best Machinery.

;

NEW YORK:

A. O. MOORE, AGRICULTURAL BOOK PUBLISHER,

(LATE O. M. SAXTON & CO.)

No. 140 FULTON STREET.

1857.

~~46.11.16~~
Apr 633.11 HARVARD COLLEGE LIBRARY
1858. May. 15.

Gift of
Henry S. Jenna Esq.
of Boston.

Entered according to Act of Congress, in the year 1857, by
AUGUSTUS O. MOORE,
In the Clerk's Office of the District Court of the United States, for the
Southern District of New York.

~~~~~  
EDWARD O. JENKINS,  
Printer and Stereotyper,  
26 Frankfort St.  
~~~~~

P R E F A C E .

So many wonderful discoveries and inventions have, from time to time, been brought before the American public, and have been so puffed and belauded by their sanguine and imaginative introducers, that a really cautious and sober minded man, mindful of these constantly recurring illusions, is not unnaturally prone to receive with suspicion and even to disbelieve statements, however true they may be, should they seem to promise more than ordinary advantage and profit from the cultivation of a new crop.

As I am well aware of this existing feeling, I am the more anxious to lay before my readers the fact, that the subject of this work, the Chinese Sugar Cane, has been fairly before the scientific world for some three or four years past ; and its various claims have been submitted to most rigid scrutiny.

In Europe it has engaged the attention of the most eminent agriculturists, chemists, sugar makers, and other competent authorities ; whilst in our own land it has been made the study of some of our most respected and trustworthy citizens, who have made fair trial of it, under various circumstances, and have stated the results obtained in various sections of the country, attaching to these statement their names, as a guaranty of their rigid exactness. So vouched for, then, the value of the "*Holcus saccharatus*" cannot reasonably be considered a doubtful fact, nor one fostered by sanguine minds for inter-

ested purposes. I have therefore addressed myself to the task of compiling all the evidence as yet placed at our disposal, strengthening it by such new facts as have reached me, and thus completed down to the latest moment, present it to the public, in the confident hope that it may prove of some interest.

Since the commencement of our existence as a nation, there has been no time more propitious to the introduction of a new sugar bearing plant, nor in which a more generous welcome would have been afforded to it, than the present; for not only are our planters filled with apprehensions because of the rapid decline of the Antilles sugar cane in the southern states, but the article of sugar has become so generally an actual necessary of life, and the number of consumers is increasing in such accelerated ratio, as to cause the demand to far exceed the supply, and thus produce a very considerable enhancement in its price. Under the stimulus of this condition of affairs, the manufacture of sugar from the sap of the maple tree, has this year been largely increased; and official statistics at the end of the year will undoubtedly show a crop of maple sugar to have been produced, such as was never before obtained in this country. But, although this crop will possibly amount to sixty millions of pounds, yet when we come to consider that in the year 1855, the amount of cane sugar consumed in the United States was *nine hundred and nineteen millions of pounds*, we are made sensible of the national interest in procuring an undiminished annual source of supply, beyond any that could be afforded by a natural increase in the yield of maple sugar.

The sugar crop of 1855, as compared with that of the previous year, showed a decrease of nearly two per cent., and the evil has since then assumed such magnitude as to influence our General Government to appropriate a large sum of money, and to send a ship to the West Indies and other adjacent tropical countries, for the purpose of pro-

curing a stock of cuttings to renew the exhausted plantations of Louisiana.

It can scarcely be a matter of surprise, therefore, that when it became bruited abroad, through our public press, that there had been introduced from France, through the United States Patent Office, a new plant, which was said to have been in common use in North China for the production of sugar, and to be capable of immediate acclimation, even in our more northern states, one simultaneous desire should have possessed the farmers of all portions of the country to experiment for themselves with the precious seed, and produce, if not for sale, at least for themselves and their families, a supply of the agreeable sugar.

Thus, then, we have seen the news passed with rapidity, from paper to paper, throughout the land ; enterprising seedsmen have imported large quantities from France, issued their advertisements, and orders and letters of inquiry poured in upon them in one unbroken stream, until the season of planting had passed. The United States Patent Office has itself distributed one hundred thousand papers of the seed ; the large crop of Colonel Richard Peters, of Georgia, has been disposed of in a similar manner ; and considering the other amounts distributed, I think to be entirely within the bounds of moderation in stating, that there are now under cultivation in the United States, *fifty thousand acres* of Chinese Sugar Cane.

The interest in the question has been materially heightened, and the hopes of success considerably increased by the arrival in this country, from Europe, of Mr. Leonard Wray, formerly a planter at Natal. This distinguished sugar planter discovered, on the south eastern coast of Africa, fifteen varieties of the *Holcus saccharatus*, cultivated by the Zulu Kaffirs, under the name Im-Fè, or Imphee, from which he made sugar in large quantities ; and which, after considerable difficulty and expense, he succeeded in introducing to the notice of European agri-

culturists. Having discovered an entirely new method, and the only practicable one, of making crystallized sugar from the juice of the im-
phee, or African sorgho, he patented his process in Europe, and came to this country with the same object in view, and has recently obtained his letters patent from the Government Office at Washington. To Mr. Wray I am indebted for the very interesting treatise* upon the imphee, which will be found in the body of this work, as also for the letters and historical matter, which will be found accredited to him at the proper place.

The success of the plant being no longer problematical then, there is immediately created a demand for some critical work upon its origin, culture, and uses; and to carry on its varied phases of manufacture will call into activity a large amount of capital and industry that has heretofore been diverted in other channels. With no hope of completely filling the existing hiatus, but as having arranged all the available materials to be found in our own, or French publications, this volume is offered to the public. The basis of it is derived from a lecture, written by myself, at the request of a distinguished friend, and delivered, on invitation, at agricultural meetings of the Legislatures of Massachusetts, New York, and Ohio, during the past winter. The flattering reception which it met, and the paucity of information as yet made public in this country, suggested the idea that, perhaps, if enlarged and illustrated with appropriate engravings, it might be of value in the present stage of our experience.

In the Appendix will be found copious extracts, translated from French pamphlets, which were placed at my disposal by Messrs. Hedges, Free, & Co., of Cincinnati and Philadelphia; and, accompanying them, the interesting correspondence between their house and the

* This treatise was printed, for private circulation, in London, 1854.

Hon. John Y. Mason, our Minister at Paris. To Mr. John W. Reid of this city, I am indebted for electrotypes of the cuts of sugar and distilling apparatus, and for much valuable information. D. Jay Browne, Esq., of the United States Patent office, has kindly sent me an article on the crystallization of the juice of the sorgho, written by him for the next volume of the Agricultural Report, and furnished for this work, in advance of its publication ; and at various times he has assisted me, with advice and information.

The Complete History of the Culture of the Chinese Sugar Cane in the Southern States, is from the pen of D. Redmond, Esq., Editor of the "Southern Cultivator," to whose labors the American public are in a great measure indebted for the successful introduction of the plant into general cultivation, and for the valuable experiments of Governor Hammond and Colonel Peters, which have so fully sustained the enthusiastic assumptions of its European friends, as to its ability to yield a large quantity of saccharine matter.

Mr. D. Jay Browne has also kindly placed at my disposal, the article containing the Chemical Researches on the Sorgho, by Dr. Charles T. Jackson, of Boston, one of the State Assayers. The analysis of Dr. Jackson will be of interest to scientific agriculturists, as affording a clue to the proper manner to apply to the sorgho fields when taken in comparison with the quantitative and qualitative analyses made at the Imperial School of Engineering.

The article by Aug. A. Hayes, Assayer to the State of Massachusetts, evinces an amount of research and scientific investigation into the composition of the sorgho, not previously equaled in this country, so far as I am aware of.

Thus aided and encouraged by gentlemen of the highest scientific and practical attainments in their several professions, the author presents this work to the agricultural public, in the sincere desire that

the plants of which it treats may prove to be what we are led to anticipate from the experience of Europe, most valuable acquisitions, and an enduring source of wealth to the American farmer.

WESTCHESTER FARM SCHOOL,
MOUNT VERNON, N. Y., 1857.

CONTENTS.

Part I.

CHAPTER I.

ORIGIN AND SUBSEQUENT HISTORY OF THE CHINESE SUGAR CANE.

The Cane in China—Accounts of Jesuit Missionaries—Extracts from Japanese Works—Its Exhibition at the Great Fair at Moscow—Introduction into Europe—The appearance of Mr. Wray's Imphee—Precarious position of the Sorgho—To whom is most Honor due—Sale of Eight Hundred Seeds to Vilmorin, Andrieux, & Co.—Various Experiments—Attempts of Pietro Arduino, in 1786—Mr. Leonard Wray—Introduction of the Sorgho into America—Sugar made by Professor Avequin, of Louisiana—How Patent Office Seeds should be used. 15-31

CHAPTER II.

DESCRIPTION OF THE PLANT.

The Confusion among Agricultural Writers—Appearance of the Plant—Height, &c.—Comparative Growth of the Sorgho and other similar Plants—Weight of the Stalk—Progressive Growth—Pulling out the Tufts—Ripening—Prostration by Wind Storms. 82-45

CHAPTER III.

SOIL REQUIRED—CULTURE—MANURING.

Should Hilling be Practiced?—Deep Culture—Subsoil Plow—Soaking Seed—Covering Lightly—Manures—Hybridization—Cultivation—Curing Fodder—Saving Seed—Stripping—Stacking. 46-56

CHAPTER IV.

VALUE AS A FORAGE CROP—TESTIMONY OF CULTIVATORS.

Sowing for Fodder—Rattooning—Cutting Fodder—Testimony of D. Jay Browne, Esq.—Testimony of Author—Testimony of Mr. Gratz, of Kentucky—Mr. Wray's Remarks at the Farmers' Club—Count Beauregard's Experience—Testimony of G. de Lacoste—Of Gov. Gardner, of Mass.—Experience of C. L. Flint, of Mass.—The Sorgho in Texas this year—Ability to withstand Drought—Curing—Its Nutritive Qualities—Size of Stalks in North Africa—Testimony of Doctor Turrel, and Lacoste—Coloring the Bones of Chickens—Yield per Acre of Seed and Forage—Should not be allowed to Grow more than one Year. 57-71

CHAPTER V.

SUGAR AND SUGAR MAKING—A WEST INDIAN SUGAR PLANTATION—CUTTING—CRUSHING—BOILING.

Apparatus Required, Fully Illustrated—A West Indian Steam Mill—Cattle Mill—Horse Mills—Stream Trains—Ordinary Trains—Vacuum Pan—Bascule Pan—Making a Small Crop of Sugar—The Cause for Present High Prices—The "African Apprentice" System. 72-128

CHAPTER VI.

SYRUP—BEST METHODS OF MAKING IT.

Experience of American Growers—The Seed obtained as well as Syrup Apparatus Necessary—M. d'Ivernois' Syrup made without a Mill—Iron

Rollers better than Wooden Rollers—Amount of Saccharine Matter
Varies in different Cases—Necessity of Cleanliness and System—Col.
Peters obtains 468 Gallons on an Acre. 129-140

CHAPTER VII.

ALCOHOLIC PRODUCTS.

Most Approved Method of Making Sorgho Alcohols—The French Experi-
ments—Brandies—The French Government Patronage—Enthusiasm
of Dr. Turrel—J. W. Reid's Experiments—Distillery—Apparatus Il-
lustrated with numerous Engravings. 141-168

CHAPTER VIII.

PAPER—VINEGAR—STARCH—DYE STUFFS—CEROSIE OR WAX.

The Quality of Vinegar—D. Jay Browne's Testimony—Count Moig-
nerie's Process Described—Dr. Sicard's Experiments, and his Method
of Vinegar Making—The Value of the Starch—Pearling and Hulling
the Seeds—The Flour—Author's Experiments in making the Dye
Stuff—Coloring Ribbons—Dr. Sicard's Samples of Colors—Chemical
Treatment to Procure the Tints—Pigments—Cerosie or Vegetable
Wax—Making Candles in China—Author's Experiments—Monsieur
Hardy's Calculations—Corn Stalk Paper—Duret's Specimens—Dr.
Sicard's Specimens—Process of Paper Making. 169-184

CHAPTER IX.

MR. WRAY'S PROCESS FOR MAKING EXCELLENT SUGAR FROM THE
IMPHEE, SORGHO, SUGAR MAPLE, BEET, AND ORDINARY SUGAR CANE
DESCRIBED.

Part II.

THE IMPHEE.

BY LEONARD WRAY, ESQ.

Discovery of the Plant in Caffraria—Previous attempts to Make Sugar
Unsuccessful—Botanical Position of the Imphee—The Different Vari-

tice—Their Description and Yields of Sugar—Cultivation—Manuring—
The Imphee Compared to the Sugar Beet and Sugar Cane.

193-228

A P P E N D I X.

Correspondence with the American Minister at Paris—Letters of Vil
morin and Vattemare, of Paris—Article by Mr. Browne, on Crystall
lizing the Juice of the Sorgho—Analysis and Chemical Researches, by
Charles T. Jackson, of Boston—French Analysis of Sorgho Stalks, Seed
and Soil—Paper by Dr. A. A. Hayes, of Boston—Mr. Wray's Letter
to Author—Author's Translations of Pamphlets of F. Bourdais—Count
Beauregard—Dr. Turrel—Paul Madinier—Duret—Louis Vilmorin—
The Reports to the French Minister of War, by Hardy and Dr. Turrel
—History of the Sorgho in the Southern States, by D. Redmond, Editor
of the "Southern Cultivator"—The Sorgho at the South. 231-350

PART I.

THE SORGHO,

OR

CHINESE SUGAR CANE.



PART I.

CHAPTER I.

ORIGIN AND SUBSEQUENT HISTORY OF THE CHINESE SUGAR CANE.

INQUIRIES into the early history of the Chinese Sugar Cane, disclose the fact that we are indebted for this new addition to our agricultural riches, (as for the ordinary sugar cane,) to that mysterious country whose name it bears, and whose agricultural products are only by slow degrees being placed in the possession of the civilized nations of the world. When we consider the jealous exclusion of foreigners, the difficulty of pursuing investigations into either the literature, manners, customs, or statistics of China, and the comparatively late date at which any communication has been opened with it, there will be little cause for wonder that the plant concerning which our investigations are about to be made, should have but just been placed within the reach of the American farmer. Nor can we consider the objection as valid, that if it really be rich in a product which at the present day bears a high commercial value, we should certainly have been made acquainted with it before; for our past experience with Chinese productions certainly warrants the belief, that not only may the Sorgho be

fully worthy of the encomiums which have been bestowed upon it by its various European cultivators, but that there may be in use in China other plants of inestimable value, which have not as yet been brought to our attention at all.

As a corroboration of this position, we have only to remember the early history of the sugar cane cultivated in our southern states. The art of cultivating the sugar cane was practiced in China from the highest antiquity; and yet, so moderate were the means of intercourse with that nation, that it was unknown to the ancient Egyptians, Jews, Greeks, or Romans; and it was not until the end of the thirteenth century that it passed into Arabia. From Arabia it was carried by the merchants to Egypt, Nubia, and Ethiopia. The Moors obtained it from Egypt, and the Spaniards from the Moors. In the fifteenth century the cane was introduced into the Canary islands by the Spaniards, and subsequently into Madeira by the Portuguese; thence it found its way into the West India Islands and the Brazils. Previous to the year 1466, sugar was known in Europe only as a medicine, brought, as were costly spices, from the East, and bearing the name of "Indian salt;" and though it was cultivated in a few places on the shores of the Mediterranean sea, still it was not more generally used on the Continent.

With these historical facts in view, how shall we be authorized in the assertion that the Chinese Sugar Cane should have of right been known to us before? The fact is, that were it not for the merest accident, even to this day we should not have been called upon to discuss its merits, or have been put in possession of its riches.

From the venerable Father Du Halde we learn that there existed, even in his time, in China, in the province of Se Chuen, situated in the western part of the Empire, a cane which produced excellent sugar, and it is supposed by Dr. Sicard that this is the same plant which has been brought to Europe. Léon de Rosny, a distinguished philologist of France, has, at the request of M. G. de Lacoste, searched the Chinese and Egyptian Archives in the Imperial Library at Paris, and speaks as follows concerning the Chinese Sugar Cane or Sorgho :

JAPANESE ACCOUNTS OF THE SORGHO.

“ The treatises on agriculture, and various other works, in the Chinese and Egyptian department of the Imperial Library, contain several chapters exclusively upon the sorghos; but their authors do not seem to have divided the varieties in such a manner as to make them correspond with those which we recognize in Europe. Besides the common Chinese and Japanese names, *Sorgho* is attached successively to other graminea which should not be, according to our system, embraced in this species. The Japanese, who, in respect to Agriculture, are eminently more advanced than all other people, even than the Chinese themselves, cultivate the sorgho *to extract from it sugar* and alcohol; but in the works which we possess, no mention is made of the coloring principle which is extracted from its seed. However, it is probable that it is not unknown to them, and that if we had at Paris a richer collection of Japanese books, we would find in them valuable and

interesting investigations on this head. We must remember, however, that the Chinese and Japanese synonyms of the *Holcus saccharatus* are not yet clearly established by botanists and orientalists. Nevertheless it seems certain that under the name of *Kibi* the Japanese designate several species of the sorgho; that the *Holcus sorghum* corresponds to 稷 (Tsi) of the Chinese, and that 蔗 (Chu) is probably a *Holcus saccharatus*.

ITS EXHIBITION AT THE FAIR AT MOSCOW.

We have a further evidence of the fact that it is cultivated in China in an article which we find in the journal "L'Utile et l'Agréable," in its number for the month of April, 1855. The writer says at Shanghae the plant is cultivated under the name of the North China Sugar Cane. The Chinese Tartars value it exceedingly; and at the Great Exposition at Moscow, in the year 1852, some of the stalks of this same species of sorgho were exhibited under the title "*Precieux Gaoullam de la Chine.*"

FIRST APPEARANCE IN EUROPE.

Its first appearance in Europe dates back no further than the year 1851, at which time the Count de Montigny, being at that time Consul of France at Shanghae, in China, sent, in compliance with official request, to the Geographical Society of Paris, a collection of plants and seeds which he found in China, and which he thought would succeed in his own country.

Among these was the celebrated Chinese Yam (*Dioscorea batatas*) and the *Holcus saccharatus*, under the name of "The Sugar Cane of the North of China."

THE APPEARANCE OF MR. WRAY'S IMPHEE.

Curiously enough, there was received in France at about the same time a quantity of seeds of a plant having apparently the same properties and almost the same appearance as the sorgho, which had been discovered on the south east coast of Africa, in the country of the Zulu Kaffirs, by Mr. Leonard Wray. The lucid, but truly surprising statements made concerning its virtues by this latter gentleman, at once stimulated in a most lively manner investigations into the properties of the Chinese Sugar Cane, and upon comparing the plants derived from these widely separate sources, the remarkable fact was made apparent, that in ability to yield crystallized sugar, to afford nourishment for stock, and in the requirements of cultivation, and other peculiarities, they were almost identical, and much surprise was created that from this double source, and as if corroborative the one of the other, a greatly needed sugar plant, and one apparently of high value, should have been given to French agriculture.

THE PRECARIOUS POSITION OF THE SORGHO.

It is a curious instance of how upon the slightest thread depend most momentous results, when we consider that, of the package of seeds sent by the Count

de Montigny to the Geographical Society of Paris, one only, one single seed, germinated in a garden at Toulon ; and if by any attack of insects, by injudicious planting or manuring, by careless cultivation, or by any one of a thousand possible mischances, the plant springing from this seed had been destroyed, France at this day would have been without the Chinese Sugar Cane, and it may be that the same opportunity would not have been again presented for a great number of years.

TO WHOM IS MOST HONOR DUE!

Much stress has been laid in the French works upon the fact that the Count de Montigny introduced the sugar cane into France, and the learned Dr. Turel, Secretary of the *Comice* of Toulon—struck with astonishment at the wonderful results which the sorgho can give in alcoholic products, its vast importance as filling a void made by the failure of the grape crop, and the governmental prohibition of the distillation of cereals—even goes so far as to claim that to the Count de Mortigny is due as much honor as is awarded to Jenner for his glorious discovery of Vaccination. Without wishing to detract from the honor due to the illustrious Ambassador, I would respectfully urge the fact that, so far as any account which we have at present goes, the Count sent the seed of the sugar cane as he sent other seeds, because they were said by the Chinese to be valuable, and because he supposed it possible that their excellences might be reproduced, upon experiment, in his own country. The gentlemen receiving the package of seeds planted them

as our American farmers receive and plant the packages sent to them by the Patent Office at Washington, oftentimes ignorant and skeptical as to their value. It chanced that into the hand of M. Robert, Director of the Marine Gardens at Toulon, were confided a few seeds of the sorgho, and he being an intelligent and enterprising gentleman and a careful observer, was desirous of knowing if, indeed, the plant would bear out the assumptions of its endorsers. He planted the seeds with care, but, to his chagrin, but one single tiny sprout appeared above the ground; and from the interest which he took in it, it is to be supposed that he continued its cultivation, and followed it through the phases of vegetation with no little apprehensions against the chances of failure. His labors were rewarded by a plant of good size, strong and vigorous, from the roots of which sprang up six ratoons or suckers. The seeds attained a complete maturity, and were distributed to the Agricultural *Comice* of Toulon.

SALE OF SEEDS TO VILMORIN, ANDRIEUX, & CO.

A gardener of Hyères, who had received part of these seeds, planted them with care, and the next year gathered *eight hundred* seeds, which were sold to the house of Vilmorin, Andrieux, & Co., seed merchants at Paris, for *eight hundred francs!* They had now come into the hands of men fully sensible of their value, capable both by education and opportunity of investigating their worth, and determined to make them available to the public. The seeds were planted by the senior partner of this house, the illustrious M. Louis Vilmorin, and numerous

experiments were made by him during the season of growth, the results of which fully established the expectations which he had been led to entertain, and gave him the basis for the work which was published by him in 1854, under the title of "Researches upon the Sorgho Sucré," or Chinese Sugar Cane.

VARIOUS EXPERIMENTERS.

Experiments were likewise instituted by members of the Imperial Acclimation Society; but by none were they more zealously pursued, nor more successfully carried on, than by the Comte de David Beauregard. This gentleman was so confident of its value, that he made strenuous efforts to increase his stock of seed, planted the greatest possible area of land with it, and succeeded so completely that it is from his third crop that has been derived the major portion of the immense amount that has been planted in the United States during the present year. In France we find it successively spreading in the provinces of la Drôme, les Pyrénées Orientales, la Haute-Marne, la Gironde, le Gers, etc., and everywhere exciting the greatest attention among the most distinguished agriculturists; and thence it quickly finds its way to that prosperous, albeit lately acquired French province of Algeria, where, according to M. Paul Madinier, a company with a capital of several millions of francs is about to be formed to cultivate and manufacture the sorgho. In 1852 there was imported into France from Russia, by M. Masson, the seed of another sugar sorgho, but the plants which sprung from them were much inferior in every respect to those sent by M.

Montigny. Dr. Sicard says that upon its appearance in Europe, the sorgho was supposed by various persons to be the millet of Caffraria, *Pain des Anges*, *Sorghum saccharatum* of Wil, *Holcus docna* of Forsk, *Holcus saccharatus* of Linnæus, *Andropogon saccharatus* of Kunth; and somewhat later Mr. Leonard Wray gave to it the name of Imphee.

THE ATTEMPT OF PIETRO ARDUINO.

Frequent reference is made in all the French works which I have translated, to the attempt made in 1786 by the Signor Pietro Arduino to introduce the *Holcus saccharatus* from Kaffirland into Italy; and to his published accounts of his experiments in sugar making. His son collected these fragments of writing, added to them his own reminiscences of his father's experiments, and issued them in a separate volume, in 1808; but at the present day it is almost a matter of impossibility to procure a copy of the work, it having passed out of print. Nothing is known, however, it seems to me, to distinctly show that the plants on which Dr. Arduino's experiments were undertaken were the same as the sorgho introduced from China; for he speaks of the seeds being of a clear light brown color, while the seeds of our Chinese variety are of a very deep purple, almost black. His description, nevertheless, exactly corresponds with the appearance of the seeds of Mr. Wray's imphee; and hence we are led to believe that it was in reality the African, and not the Chinese sugar cane which was cultivated by him at Florence. Whether it was be-

cause of the troubles which at that time convulsed Italy from one end to the other, because of want of means on his part for continuing the experiments, or because the plants were not adapted to the manufacture of sugar, I am not able to say; it is probable that all these conspired to militate against the prosecution of his studies. But I think it very possible that Dr. Arduino procured from Africa the seeds of some one of the varieties of the imphée, which required too long time to ripen to allow of its being grown in the climate of Italy; and that the small amounts of sugar obtained by him from the plants arose from the fact that the maximum of saccharine matter is only made present in the Chinese or African sugar canes at the moment of their complete maturity.

M. Louis Vilmorin, in his "Researches," mentions that in a package of seeds from Abyssinia, sent to the Museum in 1840, by M. D'Abadie, which contained about thirty species or varieties of the sorgho, he had noticed that some of the plants were particularly distinguished from the others by the sweet flavor of their stalks; but to all intents and purposes, and so far as any practical result has eventuated, from 1786 until the introduction of the Montigny seed and of that of Mr. Wray from Kaffirland, there is a complete void in European experience with the plant. Considering the question as to whom is due the honor of giving the plant to European agriculturists, there should be no cause for strife between the partisans of the Count de Montigny and Mr. Wray; for it appearing, upon the testimony of M. Vilmorin, Dr. Sicard, M. Lacoste, and Mr. Wray himself, that the sorgho and imphée are not different varieties of the same plant, but

two different species, the introducer of each plant may be duly credited without in the least depriving the other of appropriate honor. If indeed we base our gratitude upon the amount of research and labor given by the individual previous to the introduction of the plants, we certainly must agree that Mr. Wray is entitled to greater thanks at the hands of the agricultural world than the Count de Montigny, who took no great labor to discover the properties of the sorgho, but merely sent the seed, as he sent others, to be experimented upon in France.

MR. LEONARD WRAY.

Mr. Wray is widely known to the sugar planters of the world, from his authorship of the "Sugar Planters' Companion," published in Calcutta in 1843, and the "Practical Sugar Planter," published in London in 1848, and republished in French, Spanish, Portuguese, and Dutch. In 1850, he left the East Indies for the Cape of Good Hope, whence he went to Kaffirland, and found the Zulu Kaffirs cultivating the imphee around their huts, not for the purpose of manufacturing crystallized sugar or obtaining any other of its products with a commercial view, but merely for the purpose of chewing and sucking the stalks. He quickly saw of what value such plants were likely to become to Europe and America, and applied himself to their study, their culture, and manufacture into sugar, etc. After having fully satisfied himself on these points, he returned to Europe, and planted patches in England, France, and Belgium; applied for

patents in various countries; addressed the French government through Marshal Vaillant, Minister of War; exhibited specimens of sugar and the plants to Mr. Buchanan, then American Minister at London; and subsequently established the culture of the imphee in Turkey, Egypt, the West Indies, the Brazils, the Mauritius, Australia, and finally in this country. Instead of one variety as we have of the Chinese Sugar Cane, he has discovered among the Kaffirs no less than sixteen distinct kinds of imphee, of various degrees of saccharine richness, and differing very widely in the time required for their maturity.

The gift that he has thus made to our agriculture may be estimated when we reflect that we have almost every range of climate known in the world—from the torrid and fervent heats of the tropical zone to the most rigorous winters of the North; and his plants requiring in some instances but ninety days to run through the whole course of vegetation and ripen their seeds, others of greater saccharine richness requiring a more lengthened season than is necessary for the ordinary sugar cane, he has thus given to the farmers of every section of the country the opportunity to select from out his collection of varieties some one peculiarly adapted to the latitude in which he resides. Sugar, by this means, supposing his anticipations to be realized, and the experience of Governor Hammond and other southern gentlemen to be a prestige of what we can anticipate in future, will become no longer even such a luxury as it is at present, but rather will assume its proper position as a cheap, readily obtainable article of common use. It is well to remark in this place,

that in the year 1854, in the month of September, an application from Mr. Wray for a patent on his process was filed at our Government Patent Office by Charles F. Stansbury, Esq., acting in his name; but an error having been made in his application, it was withdrawn until a more favorable occasion should present itself. In the year 1856, Mr. Wray obtained the large silver medal of the *Exposition Universelle* at Paris, for his imphee sugar, alcohol, seeds, and plants, and the French government, moreover, granted to him twenty-five hundred acres of land in Algeria, to encourage in that colony the establishment of this important cultivation.

INTRODUCTION OF THE SORGHO INTO AMERICA.

In the month of November, 1854, D. Jay Browne, Esq., of the United States Patent Office, returned to America from Europe, bringing with him a quantity of the seed of the Chinese Sugar Cane, which he had procured from M. Vilmorin, the gentleman previously referred to. These seeds were distributed to various persons throughout this country; but the feeling of suspicion with which all new things are more or less viewed, tended to confine this experiment of cultivation to a few of the more enterprising farmers, until the formal report, addressed by Gen. J. H. Hammond, late Governor of South Carolina, to the Secretary of the Beach Island, South Carolina, Farmers' Club, awakened general attention, by showing the successful results of his own cultivation and manufacture. Upon its history, in the southern states, I do not propose to dwell at length, because the

full details are given in the excellent report which has been furnished to me, through the politeness of Mr. Redman. Suffice it to say, that upon the publication of a circular, containing the experiments of Colonel Peters, and the notice of the syrup which was exhibited by him at the Fair of the United States Agricultural Society, in October of the past year, the general excitement upon the subject was at once considerably augmented; and the subsequent appearance of the reports to the French Minister of War, the experience of American farmers in different parts of the country, the excellent pamphlets of Mr. J. F. C. Hyde, of Massachusetts, and Mr. Charles F. Stansbury of Washington, all have united in lending this increase to the all-prevalent interest; and the result has been, that during the present year, the seed of the Chinese Sorgho has been imported by the ton by different seedsmen, and by the agencies which we have heretofore mentioned, it has been scattered throughout the length and breadth of the land.

In 1855, I received from Paris, the "Researches on the Sugar Sorgho," by M. Vilmorin, and although at that time but very little attention had been directed to the plant, yet presuming, from a perusal of it, that it might have some future value, I translated it, entire, for the "Working Farmer."

SUGAR MADE BY PROFESSOR AVEQUIN OF LOUISIANA.

Whilst it was in course of publication, I corresponded with persons in different parts of the United States, desiring to call their attention to its merits; and having

ascertained from Messrs. Parker, White, & Gannett, seedsmen, of Boston, that the editors of the "New Orleans Bee" had received samples of sugar from Professor Avequin, of Louisiana, I opened a correspondence with that distinguished gentleman, and received from him the editorial notice of the "Bee," and an article, written by himself, for that paper, which I translated, and which will be found in subsequent pages of this work. The editors of the "Bee" clearly acknowledge the receipt of a loaf of sorgho sugar made by Professor Avequin; and I regret much at not having been able, during the past two years, to have communicated with this gentleman, and thus have been enabled to place my readers in possession of all the facts concerning his experiments.

HOW THE PATENT OFFICE SEEDS SHOULD BE USED.

We have thus narrowed down the circle of our inquiries to the introduction of the plant, and its domestication among us. In considering the slight contingency upon which hung the chance of its having been put in the possession of the French agriculturists, it seems to me a useful lesson may be derived to guide us in our practice at home. Although the General Government makes but very slight appropriations to the cause of agriculture, barely begrudging a miserable pittance out of the superfluous revenues which it has collected, yet it does appropriate a sum, however small it may be, for the purchase of seeds and cuttings for distribution to our farmers, and every year this service is performed by the department of the Patent

Office. Now if we really, as American farmers, desire to have the Government not only continue its present appropriations but increase them, we certainly should not take the seeds and cuttings which it now gives to us, and by the most culpable carelessness allow them to be utterly lost, thrown away, and rendered unproductive of any benefits to our farmers. In the majority of cases, seeds received from the Patent Office, with foreign names printed upon the packages, are looked at as curiosities, bitten to see how they taste, placed upon the mantelshelf for the examination of visitors, and subsequently put into the fire, or thrown into the top of some old closet, because the farmer cannot find time to plant them with care, and investigate their qualities. It is highly possible that among the seeds distributed for the last few years by the Patent Office, there may have been a number which, if they had been properly planted and taken care of, would have been productive of the greatest good to this country. Are we not confined as to cotton-growing to a small section of the southern states? Would it not be a source of immense wealth to our country if we could find some plant which would be a substitute for the cotton, and which could be produced in the northern and north-western states, as in this instance we have found a new sugar cane having a number of varieties, and some of them specially adapted to the cold climates of the north? and who can say but that among these seeds which have thus been lost to our farmers, there may not have been some one or more which would have produced a substitute for the cotton plant? Many of the seeds are brought home by the officers of our Exploring Expeditions, and

those connected with ships of war cruising in various parts of the world. They are sometimes obtained by them without the slightest knowledge of their properties or value; and it may be that from some distant island in the Pacific, or some rarely-visited portion of the African coast, seeds have been brought to this country which would have given us enduring sources of revenue.

CHAPTER II.

DESCRIPTION OF THE PLANT.

CONFUSION AMONG AGRICULTURAL WRITERS.

IN proceeding to consider the botanical rank of the Chinese Sugar Cane, we find ourselves at once involved in the midst of conflicting assumptions on the part of various investigators. So much confusion has arisen in regard to the plant, that M. Groenland, an associate of M. Vilmorin, has endeavored to extricate us from this confusion, and is at the present time engaged in the production of an agricultural work, which will set the matter at rest; in the mean time, from the testimony of all observers, we are authorized to accord to the plant the name *Holcus saccharatus*. Although, as M. Vilmorin says, it is inexact as to its generic character, yet it has the advantage of being known, and of not having been applied to other plants. Our seedsmen and agricultural writers seem bent upon not only maintaining this confusion of names, but also of increasing the list of synonyms, by giving to the Sorgho sucré in turn the names of half a dozen other plants. We must expect this, however; but in the meanwhile, and until the result of M. Groenland's labors are known, we are probably authorized to call it the *Holcus saccharatus*.*

* Since writing the above, we have received from Dr. Charles T. Jackson, one of the State Assayers to the State of Massachusetts, the



THE CHINESE SUGAR CANE.

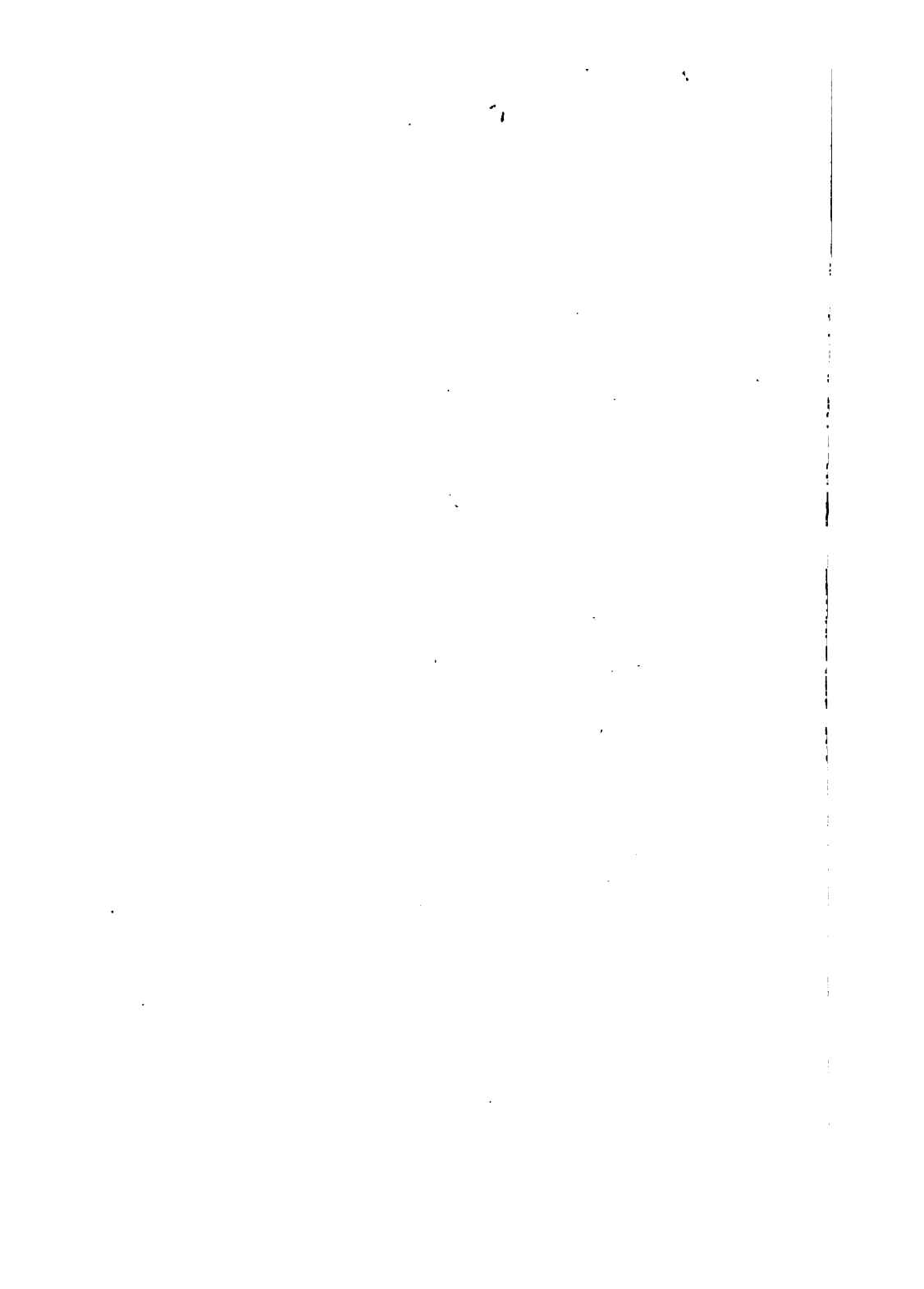

APPEARANCE OF THE PLANT.

In comparing the appearance of the sorgho with that of our common maize or Indian corn, we are struck with the superiority of the former, in respect to the exceeding grace of appearance which it presents. Like the latter,

following paper upon the botanical position of the plant, which was read by Mr. Charles J. Sprague, Botanist to the Boston Society of Natural History, at its meeting of April 15th. By it, it will be seen, that although the plant was by Linnæus termed the *Holcus saccharatus*, it had undergone subsequent subdivisions; and, as he says himself, the specific name is a matter of some doubt, so that it is as well, perhaps, to allow it to retain the name of *Holcus saccharatus*, until we obtain further advices.

“The plant was called *Holcus saccharatus* by Linnæus; but when this genus underwent a subdivision by subsequent botanists, this species was placed by some in that of *Andropogon*, by others in that of *Sorghum*. These two genera are closely allied. Some of the best authorities consider the difference so slight as to warrant their union into one. Steudel arranges *Andropogon*, *Sorghum*, and *Trachypogon* all under one head—*Andropogon*. Lindley italicizes *Sorghum* in the last edition of his “Vegetable Kingdom,” and places it beneath *Trachypogon*, evidently considering them equivalent. Dr. Gray retains *Sorghum* for our only native species (*S. nutans*) in his last edition of the Manual, considering the genus a good one.

“It is between *Andropogon* and *Sorghum*, therefore, that we must choose in reference to this particular species.

“The differences between them are these—

Andropogon.

“Inflorescence spicate.
Spikelets in pairs, only one being fertile.
Glumes herbaceous or membranaceous.
Rachis hairy.

Sorghum.

“Inflorescence paniculate.
Spikelets in twos or threes, central one only being fertile.
Glumes hard, coriaceous, or indurated.
Rachis smooth.

it presents a tall straight stalk, marked at intervals with knots or nodes, and from these, on alternate sides of the plant, spring long, spreading, tapering, and drooping leaves. The stalk very gradually decreases in diameter from the base to the top. Its outer coating is smooth and silicious, like the stalks of the maize, which becomes harder as the water and starch and the sugar of the plant become converted into woody fiber, and more silex is deposited on the outside. The seed grows upon the eight or ten separate stems which group together to form the tuft at the top of the plant; and, unlike the maize, this is the only fruit produced by the plant. When the tassel first emerges from its sheath, the seeds are nothing but a soft green husk, which by degrees, and in

“If these differences shall eventually render the genera sufficiently distinct to establish a universally recognized separation, then this plant must be placed under that of *Sorghum*.”

“The specific name is a matter of some doubt. Both *S. vulgare* and *S. saccharatum* are recorded as distinct species; but there is frequently a query appended to the latter. Some of our best authorities incline to the opinion that these two are identical, the differences between them being due to the long cultivation which the plant has undergone. We know that some of the grasses have sported into numerous varieties; and it is very probable that the Broom Corn, Doura or Guinea Corn, and the Chinese Sugar Cane, are all descended from one and the same stock.

“If we accept this as a fact, then the plant should be called *Sorghum vulgare*, Pers. var. *saccharatum*, L.; but as the latter name is so extensively known, and as there is still some doubt as to the identity, it may be as well to continue the name *Sorghum saccharatum*.”

“The true Sugar Cane, *Saccharum officinarum*, belongs to the same tribe of grasses, differing in the ample inflorescence, which is paniculate, and drooping with downy pedicles and florets.”

like manner to wheat, becomes filled with farinaceous matter, and the grains are plump and hard. The soft green pulp, as the plant approaches maturity, undergoes transitions in color, changing to violet, brown, and finally, to a purple, almost black. When this latter color appears, the plant has reached its last stage of vegetation, and will give its greatest amount of sugar. The stalk, as compared with that of the maize, is more slender and soft. The adhesion of the parts above and below the knots is not so firm, for I have found in the crops which we have cultivated at the Farm School, that a gust of wind would break the plants off at the knots when they attained considerable height, in a wet season. Another peculiarity distinguishing the sorgho stalk from that of the corn, is, that as the plant approaches maturity, we see a whitish efflorescence appear upon the parts underneath the foot-stalks of the leaf. This is a dry, hard powder, and is known to the French, under the name of *cerosie*, or vegetable wax. Of its uses and probable value, we will speak in the appropriate place.

HEIGHT, ETC.

The sorgho attains different heights as the circumstances controlling its growth are more or less favorable, and on some soils, the deep black loam for instance, grows to an enormous height, as high as sixteen or eighteen feet, while on poorer soils, on gravels or gravelly loams, or colder soils, it is shorter; but on dry, poor soils its juices have a greater tendency to crystallize. My own crop averaged the last season eleven feet in height. Some of the

stalks were full fifteen feet, and but a small proportion were nine and ten. The leaves of the plants being more slender than those of the corn, and the joints being farther apart, it will not give the same amount of green fodder to the acre, if the plants are allowed to attain their complete maturity; but this is only a comparative loss, for by suffering them to stand until this time, we procure what we cannot obtain from the corn—a full crop of sugar; therefore all the forage which we obtain is so much actual profit. The root of the sorgho is exceedingly hard and strong. Where the ground has been well disturbed, the roots run to a great depth, and acquire very great strength; so much so, that it was a matter of great difficulty for a man to pull up a stand of sorgho on our place, even after the plants had been cut off from it, and they had stood for a month or two. There is a very marked difference between the tuft of the Chinese Sugar Cane and some of the varieties of the Imphee; but there is a curious resemblance between the Shla-goo-va and the sorgho tufts. The stems of the tufts of the Chinese Sugar Cane are some of them four or five inches in length, and when covered with seeds, plump and ripe, by degrees, of course, droop over towards the ground, thus giving the tuft a feathery appearance; but the seed heads of the Vim-bis-chu-a-pa present a compact bunch of upright growing stems, albeit they are all laden with seeds, and resemble more the pompon of a military cap.

In judging of the ripeness of the imphee seed, of course the cultivator will not be misguided by any previous experience with the Chinese Sugar Cane; for while in one case he would wait for the seeds to turn

black before he would feel authorized to harvest the stalks, on the other hand, the seeds of some varieties of the African Sugar Cane, when they are fully ripe, are not darker in color than a light buff, and its only distinction then would be their plumpness and hardness.

It would be a matter of impossibility for any body but a most experienced hand to distinguish between a field of sorgho and one of ordinary broom corn in the early stages of its growth; for in appearance, size of leaves, covering, and general characteristics, it is identical. A difference will be found, however, if rows of corn and rows of sorgho should be planted together. So far as rapidity of growth is concerned, the sorgho is not a fast grower at first, and for this reason it would be very apt to discourage persons experimenting with it for the first time, as it did myself.

COMPARATIVE GROWTH OF THE SORGHO AND OTHER SIMILAR PLANTS.

An instance of the comparative rapidity of growth will be found at page 11 *et seq.* of the excellent work of Dr. Sicard.* We quote as follows :

‘ We sowed, in a warm bed, upon the same day, at the same hour, on the same kind of soil, seeds of the white sorgho, the Kaffir sorgho, broom corn, and the Chinese Sugar Cane. The seventh day the sorgho was out of the ground, the broom corn appeared in the afternoon of the same day. On the following morning we

* “ Monographie de la Canne a Sucre de la Chine, dite Sorgho a Sucre,” par le Docteur Adrien Sicard, Secretary of the Horticultural Society of Marseilles, etc. Marseilles, 1856.

saw appear the Kaffir sorgho ; and two days later the Chinese Sugar Cane."

Once out of the ground, the plants develop their leaves. It was not the same with the Chinese Sugar Cane. The latter remained for a long time before developing its leaves, its increase was very slow. Thus we see that, as compared with broom corn, the Chinese Sugar Cane requires three days more to make its appearance above the ground. A great difference is observable in the comparative flexibility of the leaves of the sugar cane and those of others of its congeners. The Chinese Sugar Cane leaves can be bent and rebent into perfect circles without breaking them, whilst the others will snap in two.

WEIGHT OF THE STALK.

Dr. Sicard, from a desire to relieve the questionings in regard to the comparative weight of the Chinese Sugar Cane and the broom corn, took from each one of these of the same length, about twenty-nine inches, and that there might be no mistake as to the identity of their period of development, measured their diameter. These precautions taken, he weighed them, and found that the broom corn weighed thirty-five grammes, and the sugar cane one hundred and thirty-seven grammes. Let those, then, who say that the Chinese Sugar Cane is no more than broom corn, that the juice of the one is as good as the other, compare this result, which, from our experience of the comparative weight of the two plants, (though we have made no precise experiment,) we should think would be a faithful indication of the differences, in the vast majority

of cases. Dr. Sicard gives in his book a very interesting and minute account of the growth of the sugar cane, from the putting forth of the first radicle until the complete maturity of the plant. Our space prevents our following him in detail, as we should be pleased to do.

PROGRESSIVE GROWTH.

The first effort at vegetation is, of course, the swelling of the seed, the separation of the valves enclosing the germ of the plant, and the putting forth of a little root. This root, unlike the others surrounding it, is of a violet hue. Its covering is impregnated with a tint on the inside of the hull. The surrounding roots are of a yellowish color. The plant rarely springs up on a single stalk. A short time after the appearance of the stalk, suckers are formed, which commence to grow upwards. The cane throws out in rudiments each one of the internodes that it must subsequently develop, and each one of these bears a leaf, which acquires dimensions larger or smaller, according to the soil upon which it is grown. The time required for the cane to acquire its full development, is about five months; but it will be more protracted or brief, as the soil is suited to its nature. In this respect, the planter will be subject to the same vicissitudes as he now has in the cultivation of the ordinary sugar cane; and we opine that, like this latter plant, the Chinese cane will be found to grow exceedingly well on the soil of a certain plantation, and on the one immediately adjoining it, give but meager results.

The present season is, perhaps, as unfavorable a one

for the institution of experiments with the new plants as we could have had; for, whereas, the plant requires a warm, dry, season to develop its excellences, and to attain a rapidity of growth, we have this year been subjected, since the earliest portion of spring, to a continued series of drenching rains and untimely showers. The soil, in consequence, has been kept cool and moist, and the temperature of the air has been so reduced that even the corn crop in the vicinity of our farm is very much more backward than it should be at this season of the year. One of the largest planters in the southern states informed me, a short time since, that he had frequently seen corn in the month of June, so tall that the tassels would be above his head when he rode through the field on horseback; but that in July of the present year, his crop was but four feet high.

There will, therefore, necessarily be much apprehension existing among the experimenters of the sorgho, as to its maturity, and it may even be that, in case the frosts set in earlier than usual in the fall, a large proportion of the plants throughout the United States will not ripen their seed-heads; but because they do not, it is no index of what we must expect, were the season but auspicious. The experiment has been tried in France of using excessive irrigation to produce an increased growth of stalks; and as in that case, although the growth was obtained, yet the proportion of the sugar in the juice was in consequence materially reduced, we may likewise expect that the rain of the present season will produce, should we have warm and favorable weather till the close of the season, a great growth of stalks, but a

diminished richness in the juice. When the panicle commences to put forth its flowers, the portion of the stalk, immediately under it, contains a quantity of sugar, equal to that which may be found later in the lower portions of the plant; but in ratio, as maturity of the seed is produced, this upper part of the stalk loses its sweet principle, which seems to descend by its specific gravity toward the root, slowly, it is true, but surely, and at the time of harvesting the cane, there is a marked difference between the comparative saccharine richness of the upper and lower portions. In noticing this fact, Dr. Sicard shows the analogy between it, and what occurs in the case of grapes. "The latter in fact commence by giving *verjuice*. In proportion as the ripening advances, they become more and more sweet; and if you only know enough to gather them at the proper epoch, and the temperature of the atmosphere is propitious, you will obtain wines of a quality; by as much more superior as the juices of the grape are more elaborated, that is to say, arrived at a more perfect maturity."

PULLING OUT THE TUPTS, ETC.—RIPENING.

It has been observed by Mr. Wray, as quoted by the French authors, that it is the practice among the Zulu Kaffirs to pull out the panicles on the stalk, at the time that they are appearing, for the purpose of concentrating the juices and obtaining more sugar; but upon this subject, Dr. Sicard says, that in taking off the panicle of the seed, when it commences to show itself, we will arrive

at an effect contrary to what is desired. He says, that he had some canes of which the stalk was broken, at different periods of its development, and that he had remarked, that according to the color of the seed, that is to say, according to the more or less continued progress of the process of ripening, the internodes the nearest to the upper portion of the plant, were more or less sweet. Thus, he says, the colors most removed from that of the ripe seed coincided with the greater quantity of sugar in the internodes nearest the panicle; but the more the plants approached the term of maturity, the more did the saccharine matter travel downwards in the stalk. In ripening, the Chinese sugar-cane takes on a yellowish tint, striped in places with red. Some of them continue to preserve an apple-green color, marked likewise with red. These colors generally indicate the term of maturity; if the red passes into carmine the cane is too ripe, and cultivators should notice this thing, in connection with the color of the seeds. At the commencement of our experience with this new plant, it is well to mention the fact, that it is subject to different maladies, some of which attack the root, and some the pith of the stalk. Dr. Sicard has made, upon this point, extensive investigations, and at page 65 of his book says, "The roots, especially the upper ones, those which we have called secondary, take on sometimes a deep violet color. If you cut these roots thus degenerated, they present in the interior the appearance of a purplish red color, which continues even as far as the radicles. The plants which have these roots, languish, take on a chlorotic tint, and end by their dying, or producing insignificant

panicles; they contain scarcely any sugar. If we express the juice from these canes, and allow it to stand for a while, there will be found at the bottom of the vessel a considerable portion of fecula, with a reddish tint, which subsequently passes into a violet tint by contact with the air. There is developed, sometimes, on the plant, much before its maturity, reddish points. If we cut into this part of the cane, it will be found to be passing from a red into a violet; having no more sweet juice, but a species of vinegar, of a very disagreeable flavor, (which is due to the ferments which are developed from the juice under the influence of the air). We have found, likewise, the larvæ of insects in the interior of the cane. Unfortunately they were lost before I could experiment upon them. We are in possession of a stalk which had received a bruise at the middle of one of its internodes. This wound, which only seemed to the naked eye a simple dot or point, controlled the violet color in all the internodes which had acquired the defects above indicated; but what is most remarkable is, that the principal nodes did not participate in any way in this alteration. This same coloring was observed upon all the canes injured by hailstones."

PROSTRATION BY WIND-STORMS.

It unfortunately happened to us, that as our crop of the last season was just approaching the time of the putting forth of the panicles, a violent storm prostrated the whole field. In our dilemma, ignorant of what was best to be done, we tried various methods of raising

them. We straightened up a number on opposite rows, inclined them towards the center, and bound them together by wisps of straw, or by strings, thinking that by treating the whole field in this manner, we might save a considerable portion of our crop; but we soon found that the knots on the canes were so tender that a very large number of them broke in two at the joints, and were thus rendered entirely useless. We discontinued the experiment, after having satisfied ourselves of its inefficacy. On the portions of the field which we left untouched, the plants were mingled together in much confusion upon the ground, and we found to our surprise, that no fermentation occurred; nor did the plants beneath die out because of the superincumbent masses, but like corn under similar circumstances, the stalks began to grow with a curve upward. In some cases, the upper ones partly elevated themselves. The ones beneath struggled to get to the light and air, in some cases protruding their panicles where an opening occurred. But Dr. Sicard, who met with a similar accident at the time when they had not thrown out their seed-heads, says, "At the end of several days they made efforts to raise themselves. The canes which were on top were nearly successful; but not so those which were buried. It seemed as if conscious that they could not overcome the weight which rested upon them, they twisted their stalks upwards, and in that prostrated condition developed their flowers in the usual way. One of them which was completely buried, and which could not reach the light, had thrown out from each one of its nodes, shoots which formed large panicles and yielded a rich harvest of

seeds. The canes have suffered nothing from this unpropitious position. It was only those which were completely flat upon the ground and in contact with the soil, which were unfit for the extraction of sugar. They had been almost completely converted into feculent matter. We should observe that we had taken the precaution to hill these sugar canes, which were thus thrown upon the soil by storm. It is to be remarked that the plants which were sown alone by themselves, which were not hilled, had not been thrown down by the wind, which corroborates the opinion previously advanced by us of the uselessness of hilling. It now seems to us proved that in letting the plant take care of itself, without coming to its aid by artificial appliances, the cultivation would be easier, and the harvest more sure. Too much care given to certain products of the soil are oftentimes more hurtful than useful." Unlike Dr. Sicard's plants, my own were not in hills, but were sown in drills at two, and two and a half feet apart. I find that some rows of canes which were planted at a distance of about a foot apart, in the row, in a more exposed position than the field which was prostrated, not only were not thrown down by the wind, but ripened their seed-heads; and from our own experience we learned the useful lesson that the Chinese Sugar Cane, like our common corn, should not be planted so near together, as, when they acquire their development, to partially exclude the free access of air and sunlight to every portion of the stalk. In fact the planting and cultivation should, in all their details, be similar to that given in the most approved practice to the corn crop.

CHAPTER III.

SOILS REQUIRED—CULTURE—MANURING.

WHEN we say that the Chinese Sugar Cane can grow upon all soils on which a fair crop of Indian corn can be raised, we have almost covered the entire question, and given the desired information; but inasmuch as upon certain soils only can the best results, so far as the production of sugar is concerned, be obtained, we deem it expedient to record a few facts which have been gathered from the observations of cultivators in all parts of the world. The experiments which have been made upon it in Algeria, France, and this country, have proved the fact that the best results are obtained on loose, deep soils; but it has been demonstrated that the juices of plants grown upon soils largely composed of vegetable *detritus*, is more abundant in fecula, and the sugar manifests a somewhat weaker propensity to crystallize than upon any others; but in such cases, as it contains a large quantity of fecula, it can be readily converted into alcohol. There seems to be a peculiar difference between the juices of the imphee and of the Chinese Sugar Cane, which is a fair representation of the difference between the juices of the Chinese Sugar Cane itself when produced under two different conditions of soil; and thus, for instance, in the Chinese Sugar Cane there is a larger proportion of fecula than in the imphee, and it is consequently necessary for the planter to take more care in his attempts to produce

the sugar. "The juice of the Imphee," says Mr. Wray, "is naturally more limpid, more free from extractive matter, and proportionably easier to defecate." In cases where the Chinese Sugar Cane has been grown on swampy land, very large plants have been produced; but the juice contains sometimes several per cent. less of crystallizable sugar, than when grown upon dry, warm uplands. The canes grown upon warm, dry soils, situated so that they can be irrigated at pleasure from a neighboring brook, according as the summer heat becomes more or less severe, will give the desired development of stalk, and they will also have much purer juices; and hence, as we before observed, the effects of the constant rains of this season will doubtless be to produce the results which have been mentioned by Professor Heuzé of Grignon, as resulting from the practice of excessive irrigation.

M. Paul Madinier says, in his little pamphlet, that for it are especially suitable light, sandy soils, and calcareous soils; but particularly those formed from alluvial deposits. That in nearly every case, especially in Algeria and the southern part of France, very excellent results will be attained by the employment of irrigation during the early stages of its growth, and when it is most rapidly developing itself; but that if employed at a later date, when it is approaching maturity, it proves deleterious, by impeding the elaboration of the saccharine principle, and rendering the canes too watery. M. Hardy, the intelligent director of the Government Nursery in Algeria, says that the sorgho flourishes extremely well on soils containing carbonate of lime, and he advises frequent liming

of such soils as are deficient in it. This recommendation finds its explanation in the astonishing success of the sorgho on the chalky soils of Champagne, where, otherwise, they obtained very mediocre results; but, says M. Madinier, if calcareous applications seem desirable, it is by no means the same of such other saline manures as have been found by experience to be unfavorable for the sugar cane and the sugar beet.

Lacoste urges upon his readers to avoid attempting the sorgho culture on soils where the soluble, inorganic matters are very abundant, because they would thus be exposed to the undesirable perplexity of producing juice in their plants of a saline character, and completely unsuitable to the extraction of sugar.

Count Beauregard says that the sorgho will flourish well on almost all soils, if they be underdrained and irrigated; but his experience shows him what would be supposed by any sensible man, that the best results are obtained on soils of the best quality that are best cultivated.

We may mention in respect to the soils, that one of the French writers speaks of having procured fine crops of sorgho from a soil on which he thinks he would not have have got a fair crop of any other forage plant; and the acre of plants which I raised myself last year, was on a coarse, gravelly loam, resting on a pure gravelly subsoil, so hard that it was a matter of difficulty to plow it, and subsoiling was almost impossible. From the experience of all the cultivators with whose writings I have met, I should advise the choice of land of medium quality, and between a black loam and a pure gravel, and of a moderate richness.

SHOULD HILLING BE PRACTICED?

There are in our own country, advanced by various cultivators, conflicting opinions relative to the practice of hilling corn. Some maintain its superior efficacy in causing the appearance of extra roots, which serve to protect the plants from prostration by storms, and others as strenuously urging that the very effort thus forced upon the plant is an unnatural one, and is met by the penalty of diminishing its strength. This same adversity of opinion has been manifested in respect to the sorgho culture. Mr. Hardy, of Algiers, hills his plants three feet apart, and irrigates them by making alongside each row a slight surface furrow with a corn plow, and turning in it a gentle streamlet of water from his brook or reservoir; but Dr. Sicard maintains that hilling is very inadvisable, because the Chinese Sugar Cane has need of roots commencing on the stalk above the surface of the ground; that, by their free contact with the atmosphere, there may be absorbed carbonic acid and other nutritive gases, and the just starting sap being thus early acted upon by gases and sunbeam, is made more prone to crystallize at a later period of its elaboration. His assumptions, he maintains, were fully borne out by the comparative experiments made on the hilled and flat cultivated plants on his field. Without assuming the right or ability to settle the vexed question as to the chemical principles involved, I would merely give my preference to the system of cultivating flat and in drills on fair soils, for with the improved implements which are so easily obtainable at this time, and without which no farmer can really

afford to cultivate his crops, the whole ground can be effectually stirred up to the very foot of each plant, and the double labor of turning at the end of rows crossing each other be avoided; the plants being spaced in the rows at a suitable distance apart, are not overcrowded as they are in hills, and they thus have greater tendency to ripen their seed-heads. I should recommend planting at three and a half feet apart, the plants in the row thinned out to twelve inches apart.

DEEP CULTURE.—SUBSOIL PLOWING.

The land should, of course, be well worked and deeply stirred, and the use of the subsoil plow has on our farm been attended with the happiest results. By its disturbing influence upon the subjacent particles of the soil, not only are spaces made through which in infinite numbers are insinuated the delicate radicles of the growing plant, but at the same time sunlight, and the trickling dew drops, and the gases of the atmosphere, descend through the interstices and conspire to assist the developments of vegetable life. To a plant which is so tardy in acquiring a rapidity in growth as the sorgho, it is especially desirable to give assistance in its early stages. The swelling of the parent seed, the putting forth of the first radicle, and the progressive accretions of matter, are all expedited by a sufficient contact with air, heat, light, and moisture. When the soil remains quite compact, by reason of much moisture present, the air, and consequently warmth, is to a great extent excluded, and the seed lying in the soil is not brought in contact with

the degree of warmth which is necessary to aid the process of germination, and thus, in many cases, will rot in the ground. The subsoil plow, running as it does deep beneath the surface, disturbs the relations of the particles from the lowest portion of its path of travel up to the topmost layers, and if its aid be called in when the seed is first germinating, or when the tiny shoot is but first above ground, the air, the dew, and the sunlight are enabled to act directly upon its roots, and they acquire great vigor and strength.

It is our practice at the Farm School to use a small subsoil plow, *with one horse*,* to mark out our rows of sorgho and corn in place of the small plow, marker, or chain commonly employed. By so doing, we thoroughly loosen the soil directly under our row of plants, and prepare for the deposit of the seed in a most thorough and excellent manner. If the subsoil plow be subsequently run *between* the rows once or twice during the season, the whole ground will have been disturbed.

SOAKING SEED.

I think very favorably of the practice of soaking the seed of the sorgho for twenty-four hours before planting. It has been found by direct experiment that seeds deprived of the hulls will germinate much sooner than those planted at the same time but not so treated. Dr. Sicard, to try the experiment, planted two lots of seed, one with, the other without the hulls, and the latter were out of the

* This admirable instrument is manufactured by Nourse, Mason, & Co., of Boston, from plans furnished by Professor J. J. Mapes.

ground in ten days, five days before the other. This method of procedure will be specially commendable in those latitudes where the warmth of summer is of brief duration, and every day that can be saved in the earlier stages of growth is highly valuable. In warm soils, which are likewise moist, the greatest rapidity of germination will be observed, and it behoves us to in some manner imitate these desirable conditions by soaking the seed for twenty-four hours in tepid water, to which is added a small quantity of saltpeter, say about one ounce to six gallons of water. Previous to sowing, it should be rolled in plaster.

COVERING LIGHTLY.

It is a well known fact that it is highly unadvisable to cover the seeds of certain of our vegetables, the carrot for instance, too deeply, lest they rot. The sorgho is not an exception to the rule, and the planter should beware lest his hands carelessly cover the seed with more than a light covering of earth; for if continued moist weather follows the planting, the seed will certainly rot in the ground.

MANURES.

In considering the question as to which manure is most suitable for the sorgho, we must recall the fact previously noticed in this work, that if the canes be grown on soils in which either naturally or by artificial application there are present excessive quantities of soluble saline matter, so much will be absorbed by the plant as

to seriously impair the crystallizability of the sap. Horse manure being violent in its action, and yielding a large proportion of ammonia, is more unsuitable than that of horned cattle, but the latter, even, is inferior to the plowing in of clover, and other green crops. From the analysis given by M. Avequin, of New Orleans, which will be found in the Appendix, it will be seen that the most important ingredients in the ash of the sorgho are the phosphates of lime and magnesia, acetate, muriate, and sulphate of potash, together with hydrated silica and oxides of iron and manganese.

Lacoste gives in his pamphlet the following analysis by M. Hetet, from the "Revue Coloniale," 1856, page 164.

Water,	70·000	} The 0·537 contains		
Salts,	0·537		Silica,	0·062
Sugar,	} 29·463	Chlorine,	} 0·475	
Woody fibre,		Sulph. Acid,		
Albumen,		Phosph. "		
Fatty matter,		Carbonic "		
Cerosie,		Potash,		
	—	Lime,		
	100·000	Magnesia,		

The water given in the Sorgho analysis, he thinks somewhat less than it should be, say two per cent.

The *bagasse*, or crushed canes that have passed through the mill, should be returned to the field and plowed under, for like those of ordinary sugar cane they will prove highly advantageous. Sicard mentions the fact that one M. Lautier sowed some Chinese Sugar

Cane in a field of potatoes, and with good results so far as obtaining a crop of large canes was concerned. Each potato had received, when planted, a handful of pigeon's dung, and the sugar canes were planted when the potatoes had attained the size of a pigeon's egg. The canes given to the Doctor were of a fine size and appearance, but he found their juices quite unfit for sugar making, because of the presence of foreign matters therein contained; thus clearly demonstrating the injurious effects of an application of ammoniacal manure. We have reason to regret that in sending the seed from Shanghae, the Count de Montigny was not at the same time able to advise us as to the details of cultivation and manuring practiced by the Chinese. Probably no country in the world can show such scientifically pursued agriculture as China, and it is a most untoward circumstance that during the present year anything should have occurred in our relations with that country to retard a closer intimacy with her people. It would confer great riches upon our farmers if some explorers could but report in detail upon the systems of husbandry employed in China, for they would be shown so superior to our own practices that they should necessarily be imitated to a considerable extent.

CULTIVATION.

As soon as the rows can be seen—and this would be hastened by dropping a radish seed in each hill of sorgho—the cultivator, or horse-shoe, should be run through the piece, to destroy any weeds while they are

small and tender. As soon after this as it is possible to spare time, we run the one horse subsoil plow twice between the rows, going up alongside one row, and down by the other. The subsequent cultivation is only a repetition of this practice.

HYBRIDIZATION.

It must be remembered, that the Chinese Sugar Cane is a congener to broom corn, Guinea or chocolate corn, Doura and Egyptian millet, and must not be planted anywhere near any one of these, for in such case it would most undoubtedly hybridize with them and lose a great part of its sugar-bearing qualities. It is thought by many extremely probable that the above varieties are only hybridizations of the same original plant.

CURING FODDER.

Considerable care should be taken in curing the fall crop for stacking. Mr. D. Jay Browne recommends cutting the stalks when the thermometer stands at 40 to 50 degrees Fahr., for it is then less likely to sour. The method of cutting practiced by Dr. Robert Battey, of Georgia, is as follows: "The fodder (leaves) should be stripped, as is corn, by the first set of hands; another set cut off one and a half to two feet of the top of the stalk with the seed, while others cut the cane at the ground and throw it into piles, from whence it is hauled to the press." It will scarcely be necessary, I trust, to urge the necessity of having got the mill and boilers in readi-

ness to crush and boil, before commencing the harvest of the crop. The canes should be allowed to lie but a short time before being worked up, and hence it will be advisable to commence by cutting and crushing the canes which ripen before the major part of the crop, and each day cutting up only as much as can be disposed of conveniently.

SAVING SEED.

The seed heads, with the two feet of stalk attached, should be made into small bundles, and laid up or hung up in the loft to dry. At a convenient season, the seed should be stripped off with a broom-corn machine, a comb, or by some other good method.* Mr. Wray has removed his seed by putting the heads into a bag, and threshing it with flails. There is a demand now created for a sorgho seed threshing machine, and it will not be long before it is supplied. The seed may be cleaned by rubbing briskly between the hands, and winnowing in a strong wind. The leaves stripped from the canes should be cured and stored for fodder.

* A suggestion for a cylinder-hatchel, for stripping the seed, will be found in the Appendix, in letter of Hedges, Free & Co.

CHAPTER IV.

VALUE AS A FORAGE CROP—TESTIMONY OF CULTIVATORS.

THE plan I purpose to pursue in discussing the claims of the sorgho to the attention of our farmers, is entirely different from those of other investigators who have preceded me; for I shall at first consider its value as a *forage crop* and a cereal, and endeavor to show that, even if we could not make from it sugar, syrup, alcohol, or any other of its products, we still have reason for congratulating ourselves upon its introduction. If this be successfully accomplished, it is plain that, whatever may be the fluctuations in its other yields of profit, it will have a regular commercial value as a means of fattening stock, and in this single department be a source of large wealth to the nation. It may possibly be that some of my more speculative readers may prefer to omit the sober considerations of this chapter, and at once pass over to the more alluring phases of the following one; but I have too vivid a recollection of former vegetable wonders not to seek to prove to our farmers that, in cultivating the Chinese Sugar Cane, they will be more fortunate than they were with the *Morus multicaulis*, which, after the subsidence of the silk fever, was found to be unfit for anything, except an application of the pick ax and plow. Although I think the sorgho is destined to rank alongside the sugar cane, Indian corn, cotton, and hemp, in the list of our industrial plants, I firmly believe that it will be con-

demned and abused by hundreds who are cultivating it this year. Not because of any fault in the plant, but because the most extravagant notions of turning a small garden patch into a rich sugar plantation have been entertained, and the hope has been unwisely put forth by some, that, without any of the proper apparatus, even without the necessary conditions of growth, large quantities of crystallized sugar could easily be obtained. As I know by personal communication, in many instances these dreams of inordinate wealth have been cherished by persons of considerable intelligence, and I sincerely trust that should these lines fall under the notice of any such, they will not intemperately throw aside a really wonderful plant after a single year's imperfect trial, but with me be content to assume more conservative grounds.

SOWING FOR FODDER.

In cultivating the sorgho for its forage, it should be sown in drills two feet apart, letting fall about fifteen to twenty seeds to the foot. I think this method much preferable to sowing broadcast, for whilst I believe the aggregate weight of fodder would be more considerable, it gives a marked superiority in allowing a "root cleaner" to be run between the drills, and the growth of enormous crops of weeds, which might spring up in broadcast sorgho, would be entirely prevented. In addition to this, the field presents a more regular and orderly appearance, the crop is easier to cut, not so liable to lodge, and in cutting off a first crop, the sunlight and air is more freely admitted to the roots and stubble, and the second crop of *rattoons*, or new shoots, is more likely to be a full one.

RATTOONING.

In speaking of ratooning, we have touched upon a property of the sorgho, which materially distinguishes it from corn fodder, and shows its superiority. The life-principle of the sorgho is so active, that if the plants be cut down when they are either small or large, and the stubble is suffered to remain undisturbed, there will immediately spring up from the old stocks a new set of canes, or *rattoons*, and if the season be long enough, the new plants will, like their predecessors, run through all the phases of growth, *and bear and ripen seed.*

CUTTING FODDER.

Hence, when cultivated for fodder, the crop should be mowed down as soon as it is large enough to feed to stock; and according to the length of the season, two, three, four, and even *five crops can be obtained.* Mr. D. Jay Browne speaks of having known of five cuttings for fodder, in Florida, last year; *the last crop perfecting its seed.*

M. Ch. d'Ivernois says, in a letter addressed to the President of the Imperial Zoölogical Acclimation Society, that the result of his extended experiments satisfies him that the sorgho is a plant of immense value. He has taken at Hyères, during the last season, five abundant cuttings on a soil light and fertile, but not capable of being irrigated, and upon which he claims that scarce any other forage crop would have given a result at all analogous. The fodder was greedily eaten by all his cattle. He thinks that the sorgho will be an acquisition of surprising value as a fodder crop for the district of

Provence, where so very few fodder plants can withstand the four and a half months of absolute drought. He believes that, as to the crop of seed, the more northern districts of France cannot hope to compete with the southern, but that it would be profitable if cut for fodder before the ripening of the grain, as a cheap and abundant supply of seed could always be obtained from more southern latitudes.

TESTIMONY OF D. JAY BROWNE, ESQ.

Mr. Browne, at the last meeting, at Washington, of the United States Agricultural Society, being called upon by the Chair, gave a most interesting history of his investigations and experience with the plant. He mentioned that in Kentucky, he knew of nine tons of fodder being raised on an acre, the weight taken after three months drying. As a fodder crop, he thought its geographical range would correspond to Indian corn, as it had been grown as far north as St. Paul, Minnesota, and fully ripened its seeds in Massachusetts and Illinois. He cited instances of cows which had been fed upon this cane exclusively, giving a diminished quantity of milk, but of increased richness of quality. He had seen two stock cows, not giving milk, which had subsisted entirely upon it for six weeks, and were in good condition for the butcher. Animals fed upon it in the green state thrive remarkably well, affording excellent milk, without exhibiting symptoms of "hoven," or flatulency, which are sometimes produced by feeding upon succulent clover or corn.

TESTIMONY OF ASA WHITNEY.

Mr. Whitney, "the Railroad Napoleon," whose dairy farm is near the city of Washington, found that if the morning's milk of cows fed upon the sorgho were put in a bottle or laid on the ice to keep it cool, by night it would have become so thickened with cream as to be removed from the bottle with some difficulty. A gentleman in Massachusetts informed me that he had experimented with sorgho in feeding a number of cows, and that it not only augmented the richness of the milk, but the *quantity* likewise.

TESTIMONY OF AUTHOR.

We have on our farm a pair of large Conestoga horses, which are kept constantly at hard work throughout the season. Last year we fed them for about six weeks on sorgho stalks, with nothing else except a little timothy hay; and we found that, although they were continually plowing, hauling stones and lumber, and performing such laborious duty, yet at the end of the time they were as sleek and fat as could be desired.

TESTIMONY OF MR. GRATZ, OF KENTUCKY.

Benjamin Gratz, Esq., of Lexington, Kentucky, President of the County Agricultural Society, informs me in a recent letter, that his son, a large planter, tried some experiments in feeding his mules on sorgho, and that "they consumed it with great avidity, leaving no residue. He also gave a portion to his hogs, with the same result.

He is under the impression that it will prove very valuable for stock generally."

Mr. J. F. C. Hyde, of Newton Centre, Massachusetts, says at page 32 of his book, "I used the seed cane stalks and leaves for fodder; cut up the stalks and fed to horses, cows, and swine, and they would eat it with the greatest avidity, even like shelled corn."

Doctor Bowman, of Illinois, has fed the stalks to his horses, and writes me in the most enthusiastic manner of its value for forage.

MR. WRAY'S REMARKS AT THE FARMERS' CLUB.

At a recent meeting of the Farmers' Club of the American Institute, Mr. Wray gave some account of his discovery of the imphee, and, among other things of his experience, mentioned the fact that it had been his practice to feed the green plants to his animals. He cuts them into pieces and sprinkles upon each mess a handful of salt. Under this treatment he finds all descriptions of stock to keep in good working condition, and increase in fat. The Kaffirs told him not to feed to his animals the bagasse; and, disregarding their advice, he lost several head of cattle, from the fact, as he learned by opening their bodies after death, that the bagasse when taken into the stomach formed itself into large balls, from the successive accumulations of which death had ultimately been caused. This undesirable result is not attained when the planter takes the precaution of adding to the bagasse the scum removed from the boilers.

COUNT BEAUREGARD'S EXPERIENCE.

The illustrious President of the Agricultural Assembly of Toulon, Count Beauregard, mentions the fact that he had "sustained for a month and a half sixty head of stock with the produce of a hectare (about two acres), which had yielded sugar sorgho the previous year, and which, by a circumstance independent of my wish, had not been resown this year, and had received but one light plowing, and no manure. This hectare was so well provided with vigorous plants springing from the seeds which had been spilled at the harvest, that I did not feel willing to turn them under, and thus we were enabled throughout the entire month July and half of August, to give to our animals an excellent nourishment, and one on which they thrive marvelously well." And, furthermore, he says, "The only thing which my very considerable experience of the past three years constrains me to add is, that this plant, contrary to what might be feared, robs and deteriorates the soil to a much less extent than many others with which I am acquainted; for I have harvested three crops in three consecutive years from the same field, with but a slight manuring in each case, and the yields have been more and more excellent."

TESTIMONY OF G. DE LACOSTE.

Lacoste says, p. 26 of his book, that if fed green to cows, the sorgho will cause an increased flow of milk, and that every portion of the saccharine stalk is eaten with avidity by cattle, and that it seems specially adapted to nourishing them.

GOVERNOR GARDNER, OF MASSACHUSETTS.

Hon. H. J. Gardner, Governor of Massachusetts, in a letter to Mr. J. F. C. Hyde, enumerates the following facts :

“As a green fodder it produces more food for cattle on the same space, and at the same cost as corn. Cattle prefer it to corn fodder; for I repeatedly gave it mixed with corn stalks to cows, and it was amusing to see them carefully select the sugar canes from the other. It is more juicy and nutritious for milch cows than any other fodder, for it is well known that sugar contains more nourishment than almost any other vegetable production in daily use.”

EXPERIENCE OF C. L. FLINT, OF MASSACHUSETTS.

Chas. L. Flint, Esq., Secretary of the Massachusetts State Board of Agriculture, in his letter to Mr. Hyde, says that he knows instances where cattle picked it out, stalk by stalk, from bundles of corn stalks; and further, “there seems every reason to believe that, as a forage plant, it will very rapidly come into general favor, and help us essentially through our summer drouths.”

CURING.

Any one of my readers who has grown our common corn for fodder, will understand that considerable care must be taken in curing the green succulent stalks of the sorgho. It should be cut in the morning, when the dew is off the plants, and suffered to lie on the ground and

become well dried before it is bound up. The bundles should be small, and before putting them in stack, or in the barns, should be set up in groups in the field to cause a further quantity of water to be evaporated. The stack should, of course, be built on rails or other convenient poles, to allow of a circulation of air beneath, and to carry out this requisition to a greater extent, it is well to build the stack around rails set up on end, and leaning inwards towards the center; by which plan, of course, the interior of the stack is in direct contact with the atmosphere, and thus heating will not so soon occur. The extra trouble of curing is repaid by the increased quantity of product, as compared with hay; but even taking considerable precautions, it may occur that an inexperienced person will not be able to save his crop in good condition on a first trial.

THE SORGHO IN TEXAS THIS YEAR.

The newspaper accounts from Texas, which have recently appeared, state the fact, that in all parts of that state the Chinese Sugar Cane has manifested its superiority to sowed corn in withstanding the drouth.

ITS ABILITY TO WITHSTAND DROUTH.

This entirely agrees with my experience of it last summer; for the sorgho did not manifest its real rapidity of growth until the commencement of the two months "heated term" which we endured. When our corn plants drooped and curled their leaves, the sorgho was not only unaffected by the heat, but daily grew in beauty

of appearance and height. When the great profits of sowing a piece of corn for fodder, to be cut up and fed to the stock in their stalls, shall have become generally appreciated, we may confidently look for the universal practice of replacing it in great part by the sorgho, both because of its multiplied cuttings, its nutritive properties, and its superior ability to withstand the scorching suns of midsummer.

ITS NUTRITIVE QUALITIES.

It may perhaps be well in this connection to refer to the fact that in Cuba the negroes, and the animals employed on the sugar plantations, are at no time of the year compelled to undergo more unremitting toil than during the boiling season; they are compelled to keep mills and boilers at work night and day, for the season allowed them to work up the crop of canes is brief, and they must employ their time to the best advantage. It is customary to work the hands in "gangs," who relieve each other alternately, one gang being at work while the other rests. Yet with all this it is a fact evident to every one who has visited an "Ingenio," or sugar plantation, that both negroes and animals, by reason of drinking the juice, and eating the stalks of the cane, are more sleek and healthy than at any other season of the year. Now this increase in fat is chemically explained by the presence of large quantities of carbon in the form of sugar, and as every one knows, sugar and fat are made of ingredients entirely the same, viz., carbon, oxygen, and hydrogen. If this be borne in mind, then it will be no more than fair to anticipate

what is really the fact, that animals fed upon the sorgho stalks, should be quickly brought into a sleek, fat condition.

SIZE OF STALKS IN NORTH AFRICA.

F. Bourdais, the distiller, at Constantine, Algeria, says, and he calls upon Mr. Hardy to testify to the fact, that on his place he has had a number of sorgho plants which sent up sixteen and eighteen suckers to a height of twelve feet, and measured four inches and three quarters in circumference at the base. Numbers of others sent up ten and twelve shoots; and the average of his field was six and seven shoots from a single seed.

TESTIMONY OF DR. TURREL AND LACOSTE.

Dr. Turrel, in his article to the *Bulletin Mensuel de la Société Imp. Zoöl. d'Acclimation*, says, that his pigs crunch the succulent and sweet stalks of the sorgho with delight. They devour the seeds, and thrive on them. Grellet Balquerie maintains that sorgho seed can be fed to horses in place of oats.

Lacoste, in a letter to the Imperial Society, says, that "the seeds fattened poultry, and for feeding to horses, will profitably replace barley; and for this one thing, pay all costs of cultivation." According to Professor Thompson,* of Glasgow, the barley contains 11.31 per cent of nutritive matter.

* Thompson's "Food of Animals." N. Y., C. M. Saxton & Co.

THE VOTE OF THE JURY OF ANIMALS.

Animal instinct is, after all, the best test of the comparative value of different substances for forage; and, taking this view of the case, we can establish beyond cavil the fact that sorgho seed is good feed for poultry and birds of all descriptions. Sundry of the French experimenters lament their inability to protect their sowings of seed from the voracious attacks of sparrows; and in one of our southern states the entire crop of seed, on a small plot in a gentleman's garden, was made way with by his chickens and pigeons.

THE COLORING MATTERS IN THE SEED.

The coloring matter in the hulls is so easily separated, and carried with the fluids of the animal body, that the flesh, and even the minute cellular structure of the bones of poultry, fed upon sorgho seed, becomes actually *dyled purple*. Mr. Wray says, he has seen in Count Beauregard's poultry-yard, the droppings of chickens fed on the seeds, that could at once be distinguished, by their purplish hue, from those of the other inmates of the yard. I have been shown, by that gentleman, a piece of pigeon's dung that had, by accident, been packed in a case of his sorgho seed-heads, and been received in this country, direct, from Hyères, which was as purple as a mulberry stain. Of course it will be understood, that this coloring matter is entirely without taste, and no injury is done to the fowl. In fact, it may become a fashionable thing to pay extra for *purple broiled chicken*.

YIELD PER ACRE OF SEED AND FODDER.

In respect to the yield of seed per acre, the north, says M. d'Ivernois, cannot hope to equal the south, where sixty bushels are produced. This result was obtained in the neighborhood of Hyères. In our own country, Col. Peters, of Georgia, obtained twenty-five bushels per acre, of thirty-six pounds per bushel. Gov. Hammond, of South Carolina, weighed a peck after three days' drying in the sun, and found the weight to be thirty-eight pounds per bushel. I have weighed several lots from Vilmorin, Andrieux, & Co., of Paris, and Count Beauregard, and found the weight to vary from forty to forty-eight pounds. Mr. Hyde says the yield is from twenty-five to fifty bushels to the acre.

Thus we see that on partially exhausted wheat soils, or alluvial soils, both of which are specially adapted to the sorgho, instead of a poor yield of wheat, we may plant the former, and, not taking anything else into consideration, obtain a crop of from twenty-five to sixty bushels of seed.

In the early portion of this chapter, I mentioned that Mr. Brown said that nine tons of dry fodder had been cut in Kentucky last season: Hon. Marshall P. Wilder, president of the United States Agricultural Society, tells me that he knows one instance where 19,844 lbs. of fodder had been obtained, the weight taken after a three months' drying. The weight of the green stalks varies from seven to forty tons, according to circumstances. The Director of the Government Nursery at Hamma, Algiers, in his report to the Minister of War (*see*

appendix), says he got a result of 83,250 lbs. of green forage, per acre. Our own Patent Office Report, for 1855, says, "Aside from other economical uses, its value for feeding to animals alone, in every section of the Union where it will thrive, cannot be surpassed by any other crop, as a greater amount of nutritious fodder cannot be obtained so cheaply in a given space within so short a time; and without wishing to present the question in an extravagant light, it may be stated, that this crop is susceptible of being cultivated within the territory of the United States, to an extent equal to that of Indian corn, say 25,000,000 acres per annum; and estimating the average yield of dry or cured fodder to the acre at two tons, the yearly amount produced would be 50,000,000 tons, which, to keep within bounds, would be worth at least \$500,000,000, besides the profits derived from the animals in milk, flesh, labor, and wool."

SHOULD NOT BE ALLOWED TO GROW MORE THAN ONE YEAR.

It is not at all desirable to suffer the stubble of canes sown for fodder to remain all winter and throughout the subsequent summer, to raise a second year's crop of fodder or sugar; for the experience of Mr. Hardy shows that the shoots of the second year are not larger than one's little finger, and attain only a feeble growth, the third season they are contemptible in size. The farmer may well be contented with the fodder of the first year's production, for if it be thought profitable practice to keep land in grass that cuts only a ton or a ton and a half per acre, what should be our estimate of a fodder crop as

good as hay, and giving *ten* tons of dried nutritious matter, with but light manuring?

If a farmer has a field lying so that he can irrigate it by damming the waters of some small creek or brooklet, and by means of a flood-gate turning the water at will into small plow furrows, running alongside each row, it certainly would be very judicious practice to put it into sorgho fodder; for as his desire is not to make crystallized sugar, or other of the products of its sweet juices, excessive irrigation will not only do no harm to his crop, but will cause magnificent growths of plants in every way suitable for nourishing his stock.

It must not be supposed that because Monsieur Hardy and others have obtained ten tons of dried forage from an acre of sorgho, the labor of every farmer, without respect to peculiarities of practice, soil, or climate, will be rewarded to an equal extent. If the proper soils be selected, and the proper method of culture be pursued, it lies within the reach of all to duplicate his success. With this culture in all its phases, forage, syrup, sugar, or any other, good judgment and perseverance will always win the prize.

CHAPTER V.

SUGAR AND SUGAR MAKING.

A WEST INDIAN SUGAR PLANTATION—CUTTING—CRUSHING—BOILING.

It is useless to conceal the fact, that, despite its great excellence as a forage crop, and despite its other manifold uses, the public are looking to the sorgho as a SUGAR PLANT with more expectation and apprehension than in any other light. Until the present feverish excitement shall have subsided into more reasonable and practical channels, it must be expected that when the vivid dreams of sugar planting in garden spots and on five acre corn fields, now, alas, so prevalent, are dispelled, and men begin to realize that a good sugar plantation, with appropriate buildings and machinery, costs a vast deal of money, much dissatisfaction will be experienced and publicly manifested. For this reason, and to shield from blows and insults a promising agricultural staple, I have chosen to consider it, first, as a forage crop.

As yet, the sugar made from the juice of the sorgho has been in a very small way—not more than a few ounces, at most, at one time—and as this chapter is written before the earliest of this season's crops have been worked up, I cannot speak of sorgho sugar making on a large scale, but must defer such remarks to appear in the Appendix, after I have been to South Carolina and

witnessed the extensive operations on the place of Governor Hammond, which, I trust, will occur in time to permit their insertion in the first edition of this work. Should the season, however, continue as inauspicious as it has been heretofore, it may be necessary to issue the first edition to fill the numerous orders already received in advance, and defer until the second edition the report on the southern experiments.

I have given in this chapter full details for the best processes of sugar making, and engravings of suitable apparatus, furnished expressly for the work by Mr. John W. Reid, of No. 11 Old Slip, New York, and made from drawings of articles which he furnishes to planters, so that in case it is proved that on our soil and in our climate either the sorgho or the imphee may really rank as sugar-producing plants, our farmers and planters may be intelligently advised as to the steps necessary to pursue to institute sugar making experiments on a large or small scale.

THE CAUSE FOR PRESENT HIGH PRICES.

Speaking of the great need which is felt for a new sugar plant, the "New York Tribune" remarks as follows :

"The recent general enhancement of the current prices of sugars, though stimulated and swelled by speculation, has a genuine basis. In the first place, there is an increase of several per cent. in the population of the civilized world within the last quarter of a century, insuring a like increase in the natural demand for sugar. Then it is not doubtful that, in the general absence of wars, the

proportion of people able to purchase and consume sugar and other luxuries to the extent of their desires, has likewise increased. It is further true that the general manufacture and use of preserved fruits, &c., is rapidly increasing. But the successive failures of the grape for several years past has led to the diversion of the beet crop of France, which is very large and important, from the production of sugar to that of brandy—the French brandies, formerly made of the juice of the grape, bearing a reputation and a price throughout the world which render this conversion highly profitable. Hence France, which, from Napoleon's coronation to Louis Phillippe's dethronement, had been steadily advancing toward the point of producing her own sugar, has recently been falling rapidly back to a position of dependence for her supply on the tropical, cane-growing Indies. It is understood that the production of sugar in the British West Indies has fallen off since emancipation; the liberated negroes finding employment more to their taste than the severe labor of the cane-field and sugar-mill; though in British Guiana the production of sugar has recently been, and is still, rapidly increasing. California and Australia have had some part in producing the general result, those countries producing little or no sugar while consuming largely, and at the same time increasing the world's bullion, and thereby enhancing the prices of nearly everything but gold.

“It is clear that the annual production of sugar must be increased; but where, and how? The severe cold of last winter destroyed a great deal of cane, and practically diminished the area of tropical cane-growing soil.

India, and the adjacent regions of Southern Asia, might produce more sugar; but their people are very slow to change the direction of their industry, while those of Spanish America have little industry of any sort. There is more sugar land in the West Indies, but it is mainly wilderness, which can only be converted into cane fields at heavy cost and by severe labor—of course, quite slowly.

“In view of these facts, inquiry has very properly been made for saccharine plants adapted to the temperate zone, and which may be profitably employed in the production of sugar. Until some plant of this sort is found and extensively cultivated, it is not probable that the price of sugar, as measured by that of wheat, beef, and other edibles, will be essentially reduced. With the prospect of an active demand and a high price for sugar through several years ahead, it seems but reasonable that the sugar-producing area should be enlarged, if that be found practicable.

“That there is no lack of plants from which sugar may be made, is well known. Indian corn, the rock maple, and some other trees, the beet-root, and sundry other esculents, contain and yield sugar, but generally at a cost above that at which it can be extracted from the cane. There is, therefore, a real and realized demand for a sugar-producing plant which may be grown in temperate latitudes, and which will yield nearly or quite as bountifully, in view of their relative cost, as the cane.”

THE "AFRICAN APPRENTICE" SYSTEM.

There is another problem presented for solution to the world, through the Government of the Emperor Napoleon, and subsequently by the British Parliament, in which, it seems to me, the sorgho and imphee are destined to have an important influence. "This proposition, when calmly examined, turns out to be nothing more or less than a project for developing the resources of the French West Indian Colonies, by the immediate introduction of large bodies of negro laborers, to be engaged on terms similar to those under which the coolies of China are now, and have for some time, been transported in very considerable numbers to the colonial territories of Great Britain." The cause for this remarkable proposition, which in reality amounts to a revival of the African slave trade, under a white-washed exterior, is found in the greatly augmented demand for sugars; and the simple problem has been forced upon the world: in what way can a sufficient staff of producers be most speedily thrown upon the soil of the great sugar-growing countries? Now, if it can be demonstrated that by cultivating the imphee and the sorgho, the sugar fields can be so widened as to embrace the countries throughout the whole Temperate Zone, of course supply at once runs parallel with demand, and the present alarming scarcity gives way to plenteous abundance. Although it is warmly urged by sugar planters, that free labor cannot compete with slave labor in sugar growing, yet this assertion must be received *cum grano salis*, for whilst tropical climates may raise sugar to the exclusion of more northern ones, when prices

are so low as to make white labor more productive in other branches of industry, yet if put in possession of plants suited to their latitudes, the greatly augmented price of sugar, at any time, would withdraw these laborers from other employments to turn producers of sugar, for their families first, and, from their surplus, to supply neighbors and friends. Thus the strife between the two is no longer one of latitude, but has become one of prices.

The common sugar cane of the tropics, "*Saccharum officinarum*," being of the same family with the plant now treated of, and its juices for the manufacture of syrup, or sugar, requiring almost an identity of treatment, as illustrating this part of my subject I append the following description, with illustrations, of the mode of cultivating cane and manufacturing sugar on the island of Cuba, from the pen of Mr. Reid, who has become thoroughly conversant with the matter by a residence in those countries.

THE CULTIVATION OF SUGAR IN THE ISLAND OF CUBA.

On the island of Cuba, farms or plantations, are divided into three distinct classes: the "Ingenio," or sugar estate, (pronounced Inhaneo); the "Cafetal," or coffee and orange estate, (pronounced Cafal); and the "Potrero," or farm, where stock, grain, or vegetables are produced. It being with the first of these only that our subject has to do, I will confine my remarks to the "Ingenio" alone; and if, in the sequel, I should at any time mention the word "potrero," it is to be understood as referring,

not to an estate exclusively set aside for the purposes mentioned, but merely as relating to that portion of every sugar estate, necessarily set apart for the raising of cattle, and for such crops of grain or fodder as are intended for its own consumption.

There are about two thousand five hundred sugar estates, large and small, to be found on the island of Cuba, ranging in size from the one having only fifty, to the one with over fifteen hundred acres of cane field under cultivation. These are the extremes, however; the average of the whole island would not exceed one hundred and fifty to two hundred acres of growing cane to each estate; requiring to cultivate these, and carry on profitably the business of the plantation, without overworking the negroes, about one negro to every two acres. Many planters, however, manage to get along with fewer hands than this; but where a good field hand is worth from eight hundred to one thousand dollars, it must be evident that the over-work which ensues from planting more cane than the gang can conveniently handle, in the end proves the most *expensive* economy the planter can adopt.

SOIL.

The soil of Cuba has two marked characteristics of color, depending upon the locality where each is found: the one, and most striking, is of a deep red or *Spanish brown* hue, which pigment it much resembles, soiling every thing which it touches of a ruddy tint—the legs of the horses and cattle, as well as the clothes of the cultivators; the other soil is a rich black mould or humus,

evidently the remains of old swamp or morass. This latter is to be found chiefly in the valleys and level tracts, while the other occupies more elevated ground. The island is evidently of coral formation, upheaved by some convulsion of nature from the depths of the ocean; and the *red land*, as it is called in contradistinction to the *black land*, seems to consist of decomposed coral rock, mixed with vegetable carbon and a metallic oxide, probably iron, which gives it the appearance referred to. • Cubans do not show preference for either soil, but in my opinion, the black soil grows better sugar, the canes being in every way superior.

Although the soil of the island is wonderfully fertile, producing, without apparent diminution, crop after crop of sugar, without other manure than the cane trash left on the ground, yet even on "the ever faithful island" this exhausting process cannot and does not go on for ever. This is evidenced by the fact that the older plantations are no longer what they were in the memory of those still living; they are beginning to wear out; the canes are becoming short, thin, and sparse; and in a few years will no doubt cease to yield sugar at all, unless the proper remedy of manure be applied. But as an evidence of the wonderful fecundity of these estates, it may be interesting to know that some of them are over one hundred years old.

CULTIVATION.

As regards the agricultural processes followed by the Creole planters, they are of the simplest kind; for, al-

though a few of the most enterprising, as well as a few planters of foreign birth, use the subsoil plow and other labor-saving machines, yet the great bulk merely scratch the soil with hoes, or small, rude surface-plows; giving as a reason for going no deeper, that if the soil be turned up, it will produce fever and cholera to destroy their negroes. So strong is this belief, that when a friend of the writer, some years ago, imported subsoil plows from the United States for use on his plantation, his neighbors remonstrated, and threatened a law suit; he persisted, however; subsoiled an old patch nearly worn out, planted his seed, and was rewarded with the finest crop of cane that had been seen in the district for years; no fever or cholera resulted, and the prejudice was eradicated in that part of the country at all events.

PLANTING—RATTOONING.

It is not necessary in the West India Islands, as in Louisiana, to plant canes every year; there being no frost there to kill the roots, they continue to throw up fresh shoots for many years, which shoots are equally good, as if sprung from canes planted each season. This habit is called *rattooning*, the canes so growing are called *rattoons*, and the roots, in favorable soil, will continue to *ratoon* every season for a long time. As an instance of this, the writer on one occasion, in Cuba, was riding with a planter, viewing his estate; we came to a fine field of cane, each cane with at least seven to eight feet of sap, and thick in proportion. The planter drew up his horse, and, point-

ing to the field, asked me what I thought of it. I examined it more critically, and although the joints were pretty close, I came to the conclusion that it was cane of the third or fourth year, and very good at that. I said so to my friend, who commenced laughing, and told me to guess its age, assuring me that it was more than three years planted. I guessed seven, ten, fifteen, and even *twenty* years, with no better success. It turned out that this field had been planted by the father of my friend, *before he himself was born*, and had yielded a good crop every year since. My friend, at the time, was over thirty years old.

In Louisiana, canes are planted generally in rows, six feet apart between the rows. In Cuba, four feet is the distance allowed between each row. A furrow, or series of holes, is made, four or five inches deep, and two joints of cane put in side by side, so that in case one joint fails to germinate, the other may supply its place. The earth is loosely drawn over the *seed*, and, with the exception of occasional weeding till the plants are strong enough to take care of themselves, little more is required either for young plants or rattoons. Latterly the Louisiana method of planting six feet apart has been introduced on some estates with good results; and there can be little doubt but that, if the same energy and intelligence prevailed in Cuba as are to be found in Louisiana, this wonderfully fertile island might be made to produce sufficient sugar to supply the whole world, so rich and recuperative is its soil, and so admirable its climate. This is owing, no doubt, to its situation in the middle of that ocean current of warm water called the Gulf Stream. Here frost never comes, and the thermometer is seldom

known to descend lower than 65° Fahrenheit in the open air.

BUILDINGS.

Situated as near as possible in the center of the plantation, is found "the mill and boiling-house," with their appurtenances of negro-house, cattle-sheds, bagasse house, &c., &c. A central position for these is selected, so as to be equally distant from all the cane fields, unless some equally important objection against it should arise. Such might be the absence of water, &c. This is first to be looked for before putting up the buildings, which are generally stone structures, with a large chimney, sixty to ninety feet high, into which all the flues of the boiling-house and engine lead. The chimney is the most important part of the whole establishment. If this should be too small, or should not *draw* properly, it puts a stop to everything. Steam cannot be got up in the boilers, therefore the mill cannot work; the sugar trains only partially boil, and general consternation prevails. Such a calamity, however, seldom happens, unless a planter should have foolishly added an additional train of kettles to an already overtaxed flue, or changed his machinery from a cattle mill to a steam mill, without enlarging his chimney, or building a separate one for his boilers. The remedy in the first case is easy; in the second, an additional chimney has to be run up with all speed. Accidents like these are great annoyances to planters, being seldom discovered until the last moment, and when every day is valuable.

PREPARING FOR CROP.

For a month or three weeks before the crop or grinding season commences, the sugar-house presents an animated scene. A general overhauling of the whole concern is going on. The cattle pump is drawing water from the river or large well, as the case may be, and it is being used plentifully everywhere; the engine and mill are being taken to pieces by the engineer (generally an American), and carefully examined, to see that no injury has been sustained during last crop. The kettles are being scrubbed out; the coolers tightened up and cleaned; the molasses tanks purified from the cockroaches and rats that have met an untimely end in them; and the whole buildings, so far as practicable, are being whitewashed with lime. In short, the sugar house has been in a state of slow fermentation since last crop, and must be sweetened by plentiful doses of lime and water, to render it fit for new operations. This being effected, the engineer informs the overseer, or *mayorál*, that he is ready to commence grinding. The *mayorál*, on his part, has examined the condition of the various cane fields, and made up his mind what field he will cut first. A day is appointed to commence grinding, probably the 10th to the 20th November. Until then a general lull takes place, and every one, from the "*mayorál*" to the latest imported "*Bozal nigger*," enjoys himself according to his taste. The negroes choose sleeping, dancing, or beating the "gumbo," and the white creoles gambling at monte, or attending the nearest "baile," or ball.

COMMENCING WORK.

The important morning at length arrives. The field gangs are told off by the *mayoral*, at daybreak, and, armed with their *machétes*, or cane knives (Figures 1 and 2), they

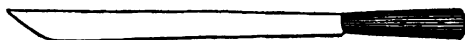
*Fig. 1**Fig. 2.*

start for the point decided upon, followed by a string of bullock carts, to bring the cane to the mill as soon as it is cut. Each field gang has its negro *mayoral*, or overseer, armed with a long, gayly mounted *machéte*, in place of a sword, and provided with a stout whip to keep loafers in order, but which, I must say, is very little used. The field being reached, those provided with *machétes* (generally two thirds of the gang), attack the canes. Seizing them with the left hand, they draw the cane slightly towards them, and with one blow sever it close to the root, strip off its leaves in a twinkling, top it, and cut it into two or three lengths, as the case requires, and throw it behind them, in less time than it has taken to describe. Women and children gather the scattered canes into heaps, from which they are loaded into the bullock carts and carried off to the mill. Arrived there, they drive under the cane shed, and deposit their loads close to the cane carrier, which is an endless chain, carrying a series of slats, or boards, leading direct

to the feed-board of the mill, and moving on rollers with the motion of the machine, but so arranged as to be stopped when required, independent of the mill. On the other side of the mill—which consists of three horizontal iron rollers, set two alongside each other, and one on the top, held in place by a very strong cast iron frame, which is bolted down firmly to the foundation—is seen another similar arrangement, for carrying away the crushed canes, or *bagasse*, after the juice has been crushed out. This is called the *bagasse-carrier*, and delivers the crushed canes directly into an ox or mule cart set beneath it, which carries it away to its appropriate receptacle. An admirable representation of the three roller horizontal cane mill, with its cane and bagasse carriers, drawn from one actually in use, may be seen by reference to the frontispiece.

CRUSHING.

Nearly enough cane having been cut to yield juice sufficient to fill all the kettles and clarifiers, fires are lighted under the steam boilers for the purpose of procuring the power to start the mill.

Steam is soon generated by the sharp, clear flame of last year's bagasse, which has been stored away on purpose, and is dry as tinder, and by this time there is a sufficiency of cane under the shed to make a commencement. The engine is set in motion, and with it the mill, the rollers of which are brought very close together by means of large screws fixed in the iron frame for that purpose. The distance between the first and second is generally one eighth or three sixteenths of an inch, while

between the second and third, if the engineer can get the blade of his knife between, he considers it about correct. The negroes throw the canes on to the carrier, which delivers them to the mill, they pass between the rollers slowly, while the juice spurts and streams down between and in all directions into the "juice pan," from whence it flows by a canal either direct to the clarifiers or is pumped up into a receiver, and thence distributed where required. Meanwhile, the canes that have been crushed are no longer canes, but *bagasse*; they are received from the carrier as before stated, and spread to dry in the sun, to be subsequently stored away in appropriate sheds for the fuel of next year.

THE BATTERY.

We have now "commenced crop;" the juice tank is full, and we must commence boiling; but, before doing so, we must describe the "battery" or "train" of kettles, how they are placed, and what is the object of each; as also the preliminary operation of "testing" the juice. The juice generally stands at a strength of seven to eight degrees in November, and ten to eleven in March and April.

TESTING THE JUICE.

Immediately on the first juice running from the mill, the planter, if he be a working man, and there are many such even in Cuba, may be seen anxiously testing the amount of saccharine matter, or sugar, in his juice, for

on this depends the value of his crop. To find out this, he uses a small instrument called a "saccharometer," either of brass or glass, as shown at figures 3 and 4, as also a small copper test dipper, figure 5, in which he floats the saccharometer.

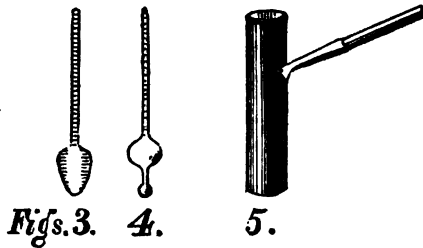

The instrument most in use is that of Beaumé, of Paris. This is marked in degrees from 0° , which represents water, up to 50° . Each degree represents, by weight, nineteen parts in a thousand of the solution of sugar and water in which it is placed. If, therefore, the juice in November marks 8° , it shows that we have eight times nineteen parts in a thousand, or $15\frac{1}{2}$ per cent. of sugar. If in March it marks 11° on the saccharometer, then we know that we have eleven times $\cdot 019$, or 20 per cent. nearly, of sugar in the juice. When the juice exceeds 11° or 12° by boiling, $\cdot 018$ is nearer the amount of sugar to a degree Beaumé than $\cdot 019$, and ought to be taken instead as a basis in making the calculation. Thin cane juice, hot or cold, will mark the same on the saccharometer, but when it is in the state of syrup, it will mark *much more cold* than hot; therefore, when you test boiling syrup, add *three* degrees to the

saccharometer to represent the true density cold. With molasses, add *four* degrees.

The range of open pans or kettles used to evaporate the expressed juice of the cane to the necessary consistency at which granulation takes place, and crystallized sugar is formed, is termed "the train," and is either a "steam," or an "ordinary" train, according as steam or fire is the medium of evaporation. Steam trains are arranged in such a variety of ways, that they possess no general character, whereas the old fashioned sugar train is the same as it was fifty years ago, with a few slight alterations, and of this alone, shall I give a description; for, after all, when properly managed, it is as good as the other for "Muscovado" sugar, and much more available in many situations.

SETTING THE TRAIN.

The latest and most improved method of setting a train, is as follows: First, suppose a straight flue, say forty feet long, one end entering the great chimney, and the other end supplied with furnace, grate bars, ash pit, and an opening, with or without doors, for pushing in the bagasse used for fuel. This flue runs along one of the side walls of the building, so that the mouth of the furnace is outside; the flue is so arranged that the upper edges of the pans, when set, shall stand about two feet, or thirty inches, above the floor of the boiling house; this puts the furnace under ground, so an *area*, as it were, is cut round that side of the house, into which the dry bagasse, for fuel, is discharged from a cart which

brings it from the bagasse house. It thus lies convenient to be picked up by the fireman, and pushed, by the arm full, into the furnace mouth.

The pans are arranged in a line along this flue, excepting the oblong sheet iron or copper defecators; these come last, and stand side by side. The flue, before reaching them, spreads, and is divided by party walls into three parts or parallel flues, each the size of the main flue; each of these passages is supplied with a sliding damper, hung and balanced by a weight, so that the fire on its way to the great chimney may be shut off from one or other of them at will, by dropping the damper in front of it. The center flue has nothing over it, and is the regular course the fire would take in going direct to the chimney. Over the other two flues the defecators are set, so that by dropping the damper in the middle flue, and raising one of the side ones, the fire is turned aside, and passing under the defecator, the damper of which has been raised, heats its contents. It may then be turned under the other by the same means. When both are heated, the fire may be shut off at the instant, and allowed to follow its old course to the chimney.

It is well to understand the proper setting of these defecators, as on them, in a great measure, depends the success of future operations. The flue is so built as to allow the defecators, which are shallow, never over eighteen or twenty inches deep, to discharge their contents, by a pipe, into the first "clarifier," which is distant sufficiently to allow of a free passage between it and the defecators; these have a platform of stone or brick around them, to allow a man to walk about and

remove the scum and feculencies. Each defecator ought to contain as much as the clarifier into which it discharges itself.

CLARIFIERS.

The first and second clarifiers are two iron pans set deep in the brick work, which is lined with light sheet copper; so as to add to the size of the pans, a sort of gutter surrounds these two. The second, which may be a little the smallest, should stand about two inches higher than the first, so that when it overflows in boiling, its contents may be able to flow back into the first kettle, but none from the first flow forward into it; the gutter which surrounds these two isolates them from the two next pans, and has an opening on one side leading to a scum, or overflow kettle, set alongside the train and furnished with a pump, but has no fire under it, being merely intended as a recipient for the scum and feculencies which have not been entirely removed in the defecator, and which are swept and skimmed from these two pans during rapid ebullition. The overflow is pumped back into the clarifiers as soon as it settles, by the pump referred to. The peculiar arrangement of the gutter, it is almost impossible to describe without diagrams.

EVAPORATORS.

Next to the second clarifier comes the first evaporator, placed deep in the brick work, and having a sort of curb

or collar of light copper, riveted to its rim; this flares considerably, and comes clear up to the level of the brick work, which arrangement nearly doubles the capacity of the vessel, and allows of the rise of the fluid and froth during the strong ebullition which occurs in this pan.

Last, and directly over the furnace, is placed the "ta-cho," or teach, arranged precisely like the preceding, but its copper curb raised an inch or an inch and a half higher; so that should it boil over, the syrup might run back into the evaporator, while the thinner liquor of the evaporator, should it in turn boil over, could not run forward into it.

Lastly, the kettles being all set, the brick work is covered with a board frame work, like a billiard table or bagatelle board, only the edges are not so high. Holes are cut for the various pans, and the whole covered nicely with light sheet copper; the purpose of this arrangement being, that suppose all the kettles to boil over, one after the other, or all at once, the overflow from the teach would run down the inclined plane into the evaporator, the overflow from the evaporator would run in turn into the second clarifier, and this into the first, which would relieve itself into the scum kettle.

Leading from the juice pan of the mill—which, for convenience, should be raised high enough, to give the necessary inclination—a wooden canal conveys the juice, and delivers it into a wooden "juice receiver," sometimes lined with copper or lead, placed somewhere near but above the level of the defecators, to one or other of which a connection may be made by a moveable trough, or suit-

able pipes. This receiver should hold sufficient to fill both clarifiers, as well as the evaporator and teach, although, except at the start, it is only required to supply the two defecators.

THE TRAIN AT WORK.

Suppose now that the juice tank is full, the movable wooden gutter is directed to each pan in succession, and fills them all nearly full of juice. The fire is lighted and the train is started; when the juice gets a little warm, a small portion of shell lime, or cream of lime, is added, according as the judgment of the sugar master may dictate, in order to neutralize the free acid present in the juice, and assist in coagulating the vegetable albumen, which has been expressed from the canes along with the juice, by the action of the mill. As the heat increases, this forms a thick scum, which is taken off as fast as it rises, by a skimmer, while the froth is beaten down by a long wooden instrument, like a cavalry saber on a large scale, the handle being prolonged two or three feet.

Ebullition soon commences all over the train, but, of course, most rapidly in those kettles nearest the furnace, and which are, besides, the smallest. As the juice reduces in the teach, it is supplied by bailing from the evaporator into it, which in turn receives from the second clarifier, while the first is filled up from the defecator. This is the mode of starting the train, but owing to the kettles being all empty at the beginning, the juice has had no regular defecation, and in consequence, should the first *strike* not turn out well, little anxiety is felt by the planter.

So far, neither of the defecators have come into play, enough juice has been collected in the receiver to fill one of them. The cock of the receiver is opened, and while it is running in, the sugar master takes a little of the juice in a glass, and tests it with litmus paper, which, from a deep blue, changes in an instant to a deep red, when dipped into the juice, should an excess of *acid* be present. The juice is always acid, more or less, therefore the question is not whether he will add lime or not, but *how much*. Having before prepared lime water, or mixed some cream lime on the spot, the damper being raised, and the fire playing on the bottom of the defecator, he stirs in small portions of the lime water or cream of lime, till the litmus paper, which at first became bright red on being immersed, now shows only a faint rose color. Here he stops, the juice is nearly neutral, neither too acid nor too alkaline, requiring but heat to make a good defecation, or separation of its albuminous and other feculencies, which, as the heat increases, rise to the top in the form of a thick, dirty crust, leaving the clear juice underneath. The moment the first signs of ebullition are perceived, the damper is let down, and the juice allowed to rest for fifteen or twenty minutes, when it may be drawn off underneath, clear and bright, leaving the dirty scum to be cleaned out when the defecator is washed for the next charge. After the train has been started, one or other of the defecators is always full, while the other is being cleaned out, and so on during the crop.

Figure 7, represents the section of a train, such as has been described, viz., four pans and two defecators.

AN ORDINARY TRAIN.

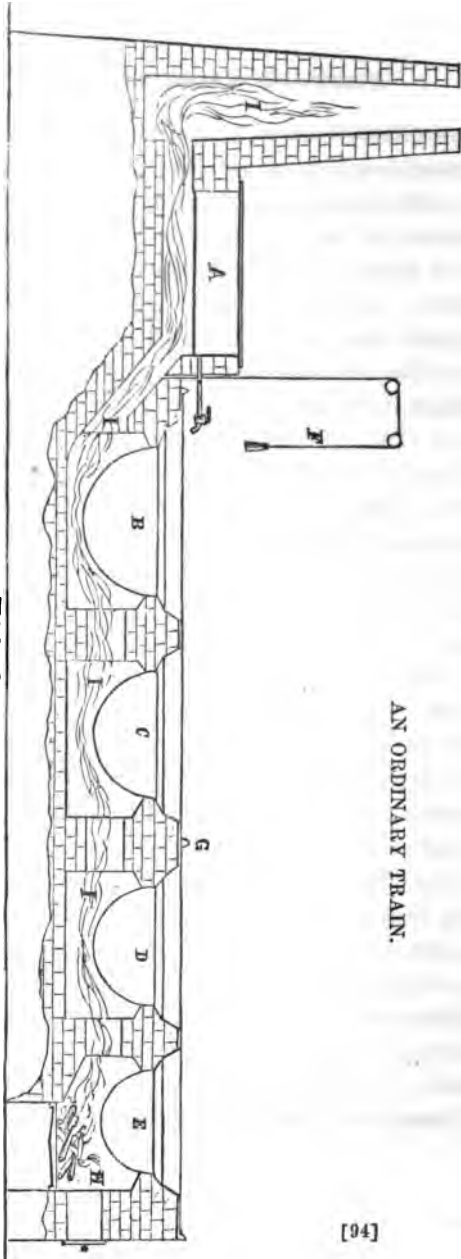

Fig. 7.

A is the defecator, B the first clarifier, C the second ditto, D evaporator, E teach, strike pan, or second evaporator, F the damper of the defecator, G a small ridge in the frame of the train, to prevent the concentrated juice from the evaporator and teach, in cases of overflow, running back to the clarifiers; H is the furnace, IIII the flue leading to the general chimney.

The following cut (Figure 8) shows a transverse section of the train, to illustrate the setting of the pans:

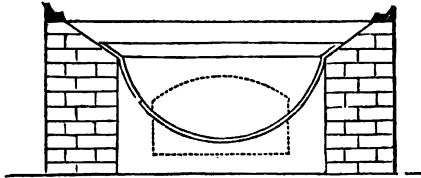

Fig. 8.

When once the train is started it goes on night and day, with an occasional stoppage of a day, now and then, to wash up, clear out the juice tanks and gutters, and do any little repairs that may be necessary, as well also as to give the negroes a holiday, which at this time they employ in sleep; not getting too much of the latter while crops last, especially if sugar is high, and it is an object to get it soon to market.

Belonging to every estate there are a *few* old hands experienced in sugar-boiling, who can make just as good a strike of sugar as any sugar master, and to them is intrusted the operations of the "battery," with the sugar

master to overlook them. But, it may be said, if these negroes boil so well, why employ a sugar master at so much expense every year? The fact is, there is no dependence to be placed on the negro, for just at the most critical point when the sugar ought to be "*struck*" into the cooler it is very probable, if left to themselves, they would lie down and go to sleep, not from fatigue, but laziness, or thoughtlessness, and yet they take considerable interest in their owner's concerns.

At the commencement of crop, when the first strike is nearly finished, all the interest of the sugar-house centers in the lazy, rich, golden fluid in the teach, which has ceased to froth or bubble, and from which the steam is now escaping in short puffs. The old negro, who has probably boiled at that train for twenty years, and knows exactly how the juice of the estate works, after taking a little of the syrup between his finger and thumb, and watching what *string* it made, informs the sugar master that the sugar is ready to strike into the coolers. He, who probably has never boiled on the estate before, and has yet to *learn* how its juice must be treated, has wisely left the matter in the hands of the negro. However, it will not do to let Sambo suppose that he knows more than his master. So the sugar master, who knows that half a minute will not make much difference, delays the strike for that time, pulls out his watch, if he has one, looking very wise, and at length consents to let Pancho or Pedro adjust the gutter, from the kettle to the cooler ten feet distant, and discharge the pan. The fireman is bawled to to stop the fire, and the sugar is bailed into the gutter to be conducted to the cooler.

The annexed cuts represent the appliances for skimming, dipping, bailing, and striking.

Figure 9 is the common dipper, used for almost all the purposes of handling small portions of juice or syrup.

Figure 10 is the bailing dipper, holding five or six gallons, and used to remove the charge of one kettle into another, as also to strike the charge into the coolers.

Figure 11 represents the ordinary skimmer, for removing the scum from the clarifiers.

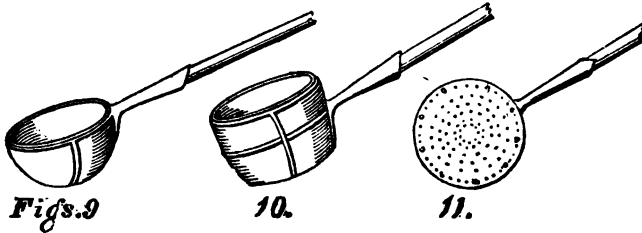

THE COOLERS.

These coolers are generally oblong wooden troughs, made of two inch pine wood, ten feet long, five feet broad, and ten to twelve inches deep. They are set parallel with the train in a double row, six in each row. Each cooler holds three "strikes," which are not made one over the other directly, but as follows: three strikes are made in three separate coolers, then commencing with the first again. This is to give the first strike an opportunity to cool. While the sugar is cooling, the sugar master takes a light wooden instrument, like a small rake without teeth, and hauls it up and down the cooler so as to agitate the mass and promote crystallization; once

after each strike is often enough to do this, and in a few hours the sugar ought to set, or *grain*.

On the second or third day it is usual to empty the coolers; two big stout negroes, bare all but a "breech clout," get into them with shovels, and dig out the sugar: not so easy a job, now that the crystal has got set. A dozen women get their small copper basins or tubs filled with the *melado*, or unpurged sugar, and carry it on their heads to the purging house, where hogsheads, with holes duly perforated in the bottom, have been prepared beforehand. They empty their basins into the nearest until it is full, and so on to the next.

PURGING.

The sugar when it goes into the cooler, is a dark, brown-looking substance, being composed of sugar and molasses, mixed in the proportion of say sixty of the former to forty of the latter. This, when put into a hogshead with a perforated bottom, soon begins to drip or purge, provided the place be moderately warm. The floor of the purging house is nothing more than joists without boards, while underneath is a large tank or tanks of wood or concrete, to receive the molasses as it drops down as the hogshead purges. The sugar settles, and this has to be supplied by fresh additions either of purged sugar from other hogsheads, or by more *melado* from the coolers. After about thirty days, it is headed up, and taken out of the purging house, and either put into the storehouse, or, with another hogshead on a bullock-cart, it is sent to the nearest seaport.

THE CLAYING PROCESS.

On some estates only a portion of the sugar is made into Muscovado, which is the process I have been describing. To make "clayed" sugar requires a little different treatment; it is as follows:

Conical moulds, of tin, zinc, or sheet iron, with an aperture at the small end, are provided—for large estates to the extent of many thousands. These are set on the floor of the purging house, on perforated boards, which receive the small end and keep them upright. The aperture at the bottom, which is three quarters of an inch to one inch wide, is stopped either with a piece of wood prepared for the purpose, or, as is often done, a joint of cane is used as a *plug*. The sugar, being boiled a little *stiffer* than if intended for the cooler, is first put into a wooden box running on wheels, rather deep and long, in which it is agitated with a short oar for some time, until it has cooled somewhat, and crystals have begun to form. It is then *filled* into the moulds, the box being wheeled alongside of them. These moulds contain from eighty to one hundred and twenty pounds of hot sugar. In a day or two, when the sugar master considers that the contents of the moulds are well crystallized, the plugs are removed, and the molasses soon begins to separate from the crystals and run out. The operator to hasten this, however, and, as it were, to wash the crystals as clean as possible, gets some good porous clay, mixes it well into a thin, creamy paste with water, and pours it over the top of the sugar in the mould. The clay remains on the top of the sugar, while it allows the water to percolate

down through the loaf, and thus wash the crystals free from their mother liquor, or molasses. When the water has all left, the clay may be lifted off the mould like a large brown cake of gingerbread, without soiling the hands or injuring the sugar. This is what is termed "claying," and produces the "clayed" sugar of commerce.

If the sugar is desired to be very white, claying may be repeated two or three times, but each time at the expense of the crystal, which is washed away just in proportion as the sugar whitens. When well purged, the sugar is got out of the moulds by knocking them upside down on a clean floor. The loaf of sugar will be found of three grades—white at the top, yellow in the middle, and brown towards the bottom, whilst the tip or extreme end remains a "magma" of sugar and molasses.

DRYING—BOXING—SHIPPING TO MARKET.

As the moulds are knocked out, the different grades of sugar are separated, by breaking the loaves across by a blow with a *machete*, which is the instrument of all work in the hands of the negro; the broken loaves of sugar are then either passed between rollers, or pounded with mallets, to break up its consistence. After which, it is either spread over hot tiles, in a room prepared for the purpose, with fires underneath, or exposed, on boards, to the rays of the sun. Here it is dried to powder, and afterward packed in oblong boxes of rough pine board, held together by strips of raw hide; which being nailed on the box when moist, contract on drying, and bind the

box together in the firmest manner. These are what are known in trade as "boxed" or "clayed" sugars, and are much sought after by refiners.

CATTLE MILL.

Besides the many sugar mills which are driven by steam engines, there are a large number of the original vertical cattle mills, with wooden frames, still in use, in situations where water is scarce, or the crop does not justify the expense of steam machinery. One of these is represented at Figure 12.

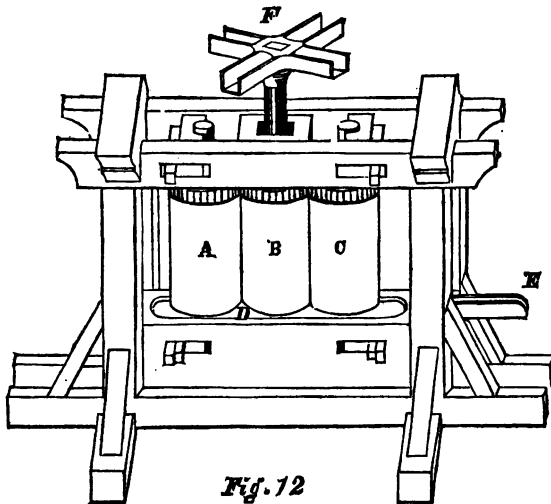

Fig. 12

A B C are the vertical iron rollers, and E the spout conducting the juice from the pan to the canal or gutter

leading to the juice tank. In cattle mills this gutter is put under ground, so that the cattle may pass over it without obstruction. Attached to the upper part of the center roller may be seen a cast iron cross-head with sockets, into which wooden bars are fitted, to which are harnessed the oxen, mules, or horses, as the case may be. Large mills of this kind, require sixteen oxen.

The frame of the mill being of wood, it necessarily gives somewhat to the extreme strain upon it, consequently the canes are never so thoroughly crushed as with the iron frame mill, but the juice, though less in quantity, is invariably better in quality. The reason for this is, that the tissues of the cane not being so completely broken up, as in the former case, less of the albuminous and extractive matter is obtained in the operation; the juice is purer, clarifies easily, and makes very bright sugar, commanding an advanced price. It is a question, however, whether the advance in price which such sugar generally commands, makes up for the loss in the quantity of the juice, which the employment of the cattle mill necessarily entails.

SMALL TWO ROLLER MILL.

A small two roller vertical mill, suitable for farmers planting one or two acres of sorgho, and which may be driven by two men, or one horse or mule is shown at Figure 13. This little mill is fastened securely in the ground by means of its uprights, which renders it convenient for farmers.

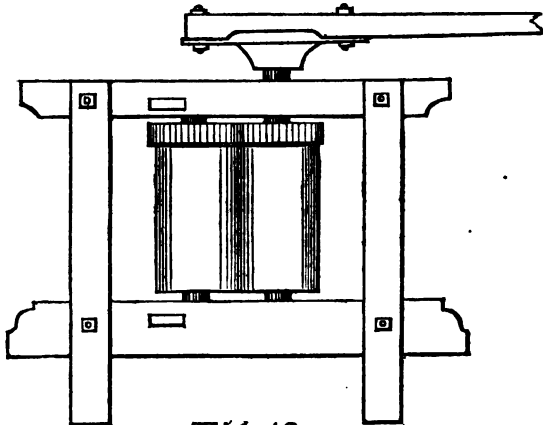
*Fig. 13.*

STEAM TRAIN.

Hitherto I have only treated of sugar trains which evaporate over the naked fire, but there are a large number of the more extensive estates where steam is employed throughout, while there are others where the two systems are united. I shall finish my remarks on sugar boiling, therefore, by a brief notice of these methods.

I have observed, with others, that nearly the whole of the color imparted to cane juice in the act of boiling over the naked fire, is received in the two last pans, after the fluid has become comparatively dense, and retaining but little water to carry off the heat. Steam does not discolor the sugar nearly so much as fire, therefore steam trains have been extensively adopted, and great expense has frequently been incurred in altering the arrangement of the

boiling-house to suit the new *regime*. A steam train will cost twice as much to run and keep in order as a common train will, to say nothing of first expense; therefore, to make use of only so much of the steam train as is absolutely necessary to effect the end required must be an object.

Cane juice, containing the large proportion of water which it does, until it is evaporated to 30° or 32° of Beaumé's saccharometer, remains so lively and changes its position so readily in the pan, in the act of boiling

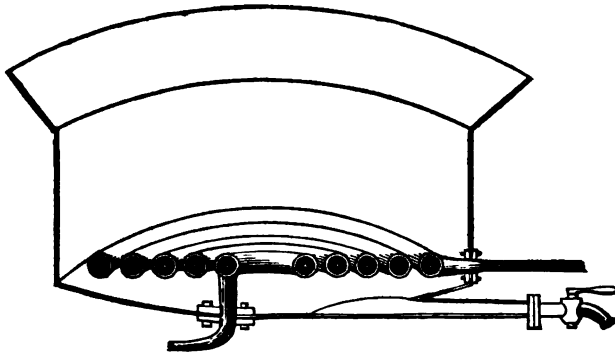

Fig. 14.

over the naked fire, that no danger of discoloration need be feared, till it reaches the stage referred to; here, however, it should be changed to the steam pans and finished.

I think the reasons given are sufficient for retaining the old and inexpensive train, for the purpose of evaporating the juice to 80° B., after which the process may be continued in suitable pans having coils of copper steam pipe in the bottom, as represented in section at Figure 14.

Or "McCracken's Patent Evaporator" may be employed in place of the worm or coil. These evaporators have the property of boiling with immense rapidity, requiring comparatively low pressure of steam, say 30 lbs. to the square inch, thus uniting in themselves those properties which constitute the best sugar apparatus, viz., great speed with low temperature. With the ordinary coil, 75 and 100 lbs. are the usual figures. This system is shown at Figure 15, of which A A is the pan, of iron or copper ;

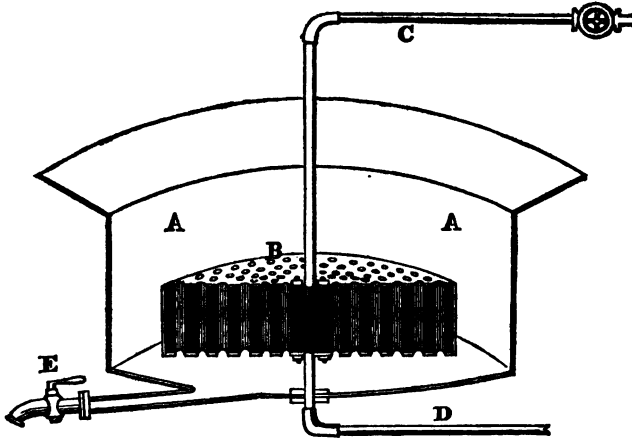

Fig. 15.

B, the evaporator, consisting of a case, or cylinder, full of tubes, into which the steam enters, and surrounds the tubes ; C is the steam pipe from the boiler ; D the condense water pipe, and E the cock where the sugar is discharged. By means of this system the pipes are *surrounded by the steam*, instead of *surrounding or containing it*, as in the old way ; and so the juice flows into those pipes both at

top and bottom. It will be perceived that the whole force of the steam is applied to small portions or columns of liquor at a time; thus an immediate evaporation takes place almost as soon as the steam enters the tube cylinder, while all danger of overheating is avoided, by the well known tendency of liquids to rise when heated. A current sets up through the tubes, the cooler portion entering below, heating as it rises, and flowing out at the top, until, when the whole mass gets thoroughly heated, the juice in ebullition takes the form of a fountain, and vaporization goes on with wonderful rapidity. This pan is fast coming into favor, and that it will ultimately supersede all other methods of open evaporation by steam, is the opinion of planters who have it in use.

BOILING IN VACUO.

Besides the preceding, there is yet another method of evaporating, the apparatus for which is more complicated and expensive than either of the others; this is boiling "in vacuo," and was invented by Lord Howard, a scientific Englishman, many years ago. So complete was the apparatus he adopted, that, with a few minor additions, his pan remains in principle unaltered to this day.

The principle involved in the vacuum pan is that by which watery liquids may be made to vaporize in a vacuum at a much lower temperature than in the open air. Thus, water boils in the open air at 212° , while in vacuo the same takes place at 90° . Advantage is taken of this in sugar boiling to extract the water from solutions of sugar at a low temperature, and so preserve its color.

The vacuum pan is merely a closed metallic vessel, having a coil of steam pipe in the bottom, and a condenser to condense the steam as fast as it rises, while an air-pump removes the atmospheric pressure and water of condensation. This pan is shown in elevation at Fig. 16, of which A is the pan ; B, the belt ; C, the cover, or

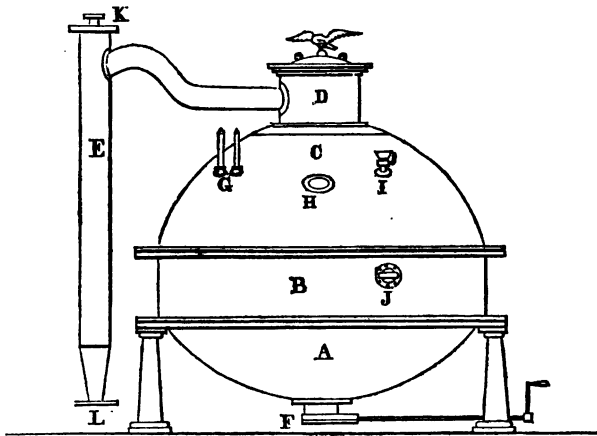

Fig. 16.

dome ; D, the cap and collar ; E, the condenser, to which a cold water pipe is attached at K, while the condenser discharges at L, connecting by another pipe with the air pump, which is worked by water power or steam engine. F is the discharge valve, or gate ; G, a barometer, to show the extent of the vacuum, and a thermometer to indicate the heat of the pan ; H is an eye glass, another being on the opposite side of the dome, for the purpose of observing the ebullition of the "charge ;" I is a small cup-faucet, or grease-cock, to introduce a little oil when

it is required to check the froth in the pan, serving also to admit air when the sugar is ready to be discharged; J is the proof-stick, by which a small quantity of sugar may be withdrawn from the pan at pleasure, so that the operator may know, from time to time, how the charge is progressing.

The method of operating with the vacuum pan to best advantage on a sugar estate, is to boil the sugar as I have before advised in the old train, till it reaches a density of 30° or 32° Beaumé, after which, introduce and boil in vacuo to the crystallizing point. It would be too tedious, as well as too expensive, to boil down raw cane juice in this way. Rellieux, however, by means of three closed pans, operates on the raw juice in this way; with what economy I cannot say, never having examined the process thoroughly. His train is very costly, of course.

Unlike boiling in the open air, owing to its low temperature, granulation, to a considerable extent, takes place in the vacuum pan, if the operation be properly conducted, and the vacuum well preserved, to do which, like everything else, requires practice in the operator. The sugar, when discharged, instead of resembling thick syrup, as it would if boiled in the open pan, resembles thin mortar, being full of *grain*, and requiring but a slight decrease of temperature to become solid.

THE FRENCH BASCULE PAN.

At figure 17, I give a representation of the old French Bascule pan, which was superseded by Howard's process.

For the purpose of evaporating sorgho juice, on a limited

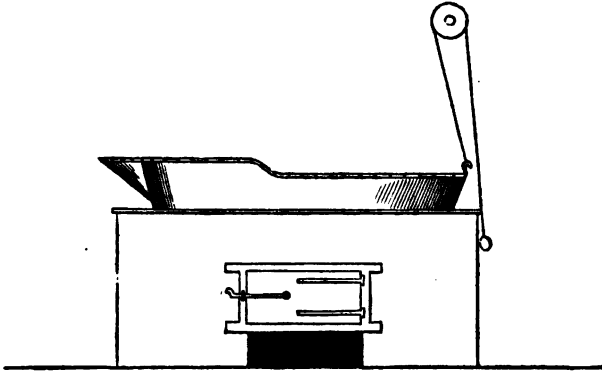

Fig. 17.

scale, I think it would do good service; the fire only strikes the bottom, and the syrup, or sugar, is discharged at a moment's notice. I should recommend it to such farmers as do not intend putting up a full train.

BAG FILTERS.

Where white pure sugar is wanted direct from the cane, a refining process is required, similar to that employed in refineries in the city. The cane juice, after defecation and clarification, at a density of 12° or 13° B. or even as high as 24° or 25° B., is run through *bag filters*, which are made of a peculiar kind of cotton duck; they consist, simply, of a large bag, usually a yard wide, and five or six feet long. This is gathered together closely, and drawn through a *sheath* of the same length, (like a cut of leather hose pipe, only made of porous flax bagging,)

the open end of the cotton bag being all "puckered up," is tied on to a brass tube, which, being fitted with a screw, is screwed into a small shallow cast iron or wooden tank, large enough to contain twenty-five to fifty of these brass tubes; the tank, besides serving to hang the filters, (which hang like so many sausages,) serves to contain the syrup which is to pass through the tubes into the bags, through which it percolates, and emerges clear and bright, free from feculencies and extraneous matters, and ready for the carbon filters.

BONE BLACK FILTERS.

These latter are large square or circular sheet iron tanks, which should be at least five feet in diameter, and six or eight feet deep. These have a false bottom perforated with holes; over this a blanket is laid, and the tank filled up evenly with animal charcoal or *bone black*. A small air-tube generally runs from beneath the false bottom to the top. Over the top of the bone black the bag-filtered liquor is permitted to flow, which soon filters down through the false bottom; the cock of the filter is then opened, and the first running kept apart, being black and smutty from the small particles of charcoal dust which it contains. This is thrown on again at the top to be refiltered. The stream, however, soon runs clear, and, according to the length of time the syrup is left in contact with the bone black, does the decolorization sought for take place. If the stream be kept small the liquor may be drawn off colorless as water, and so

darker, in proportion to the speed with which it is run off.

Filtering in this way is a very expensive process even in large cities where labor is cheap, the *bone black* requiring to be reburned as soon as it has filtered three times its own weight of sugar. I would not, therefore, advise the use of filters on a sugar estate or farm; the true policy of which ought to be to make good Muscovado, and leave refining to the cities, where all the facilities exist for doing it to advantage, and with an economy which the planter or farmer may seek in vain to imitate. The syrup, after passing through the filters, is ready for the vacuum pan.

In the preceding remarks on the various apparatus for, and processes of, manufacturing sugar, I have not attempted clothing my subject with any of the elegances of language, but more to convey in as simple a manner as possible the information required, in the hope that it might assist in developing a new branch of industry in the community, and so add to the wealth and prosperity of the country at large.

GROUND PLAN FOR SUGAR ESTATE BUILDINGS.

The following cut represents the ground-plan of buildings for a sugar estate, with the engine house, boiling house, cooling and purging house, arranged on a combination of the best features, gathered from various sugar estates of Louisiana and Cuba:

As will be seen in the cut, the engine house, boiling house, and cooling and purging house, are all built sepa-

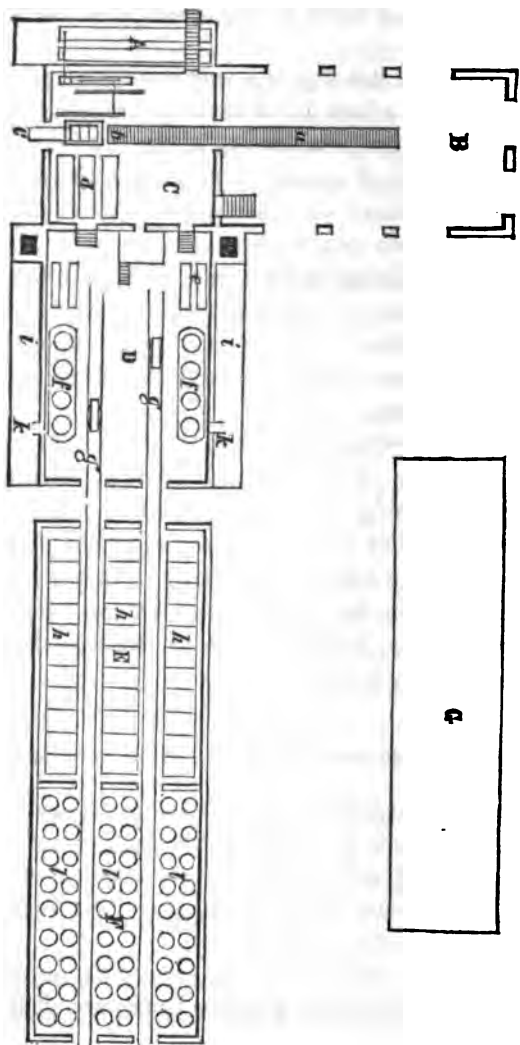

GROUND PLAN OF BUILDINGS FOR SUGAR ESTATE.

[For Explanation, see p. 108.]

rate, with a space between each ; the gable walls of these buildings ought to have no windows, and the doors communicating should be of iron, so that in case any one of the buildings caught fire, the conflagration would be confined to the place where it originated, and thus the valuable stock or machinery in the other buildings be saved.

CHEAP AND SIMPLE PROCESS FOR MAKING SUGAR OR SYRUP ON A SMALL SCALE.

For the benefit of a large class whose facilities or inclinations have this year induced them only to plant a small patch of Chinese Sugar Cane, by way of experiment, yet who, nevertheless, are desirous of making a trial of syrup or sugar making on their own account, without waiting for the voluminous reports which will be forthcoming at the end of the season, I subjoin the following description of a process by which, at a trifling expense, both syrup and sugar may be manufactured in a small way for family use, by any farmer or householder who has but a few canes growing in his garden, and which may be applied to any operation on from five to twenty-five gallons of juice.

Of course, the first thing is to permit the sorgho to fully ripen, as in that condition it makes the best syrup, and will be free from the grassy flavor complained of in previous experiments. This, as has been previously said, is known by the seeds becoming black and hard. When fully ripe, then, with a corn-cutter, a large carving knife, or, what is better, a small hatchet, cut the canes off close to the roots, strip off their leaves as far as the joints

extend, and chop off the rest of the stalk, saving the seeds for future planting, if the cane proves to be of good quality ; if not, give them to the chickens.

The next thing is to extract the juice from the stalks or canes. This must be done by pressing them between rollers. If there is a cider mill on the premises, it will be all-sufficient ; pass them through it just as you would crush apples, catching the juice in some clean vessel with as few chips or dirt in it as possible.

A VERY CHEAP MILL.

If there be no cider mill in the neighborhood, you must make a shift to construct one yourself, or get the nearest carpenter to do so ; nothing but wood being required for all you have to do. The way to go about it is as follows : Choose some straight pieces of maple, or any hard wood, twelve or fourteen inches across, and saw one piece off thirty inches long, and the other forty-eight inches. These are to make your two rollers, and as nearly round as you can get the log, so much less trouble will there be to fashion the work. Having got your wood, take the blocks to the nearest carpenter, and tell him to make you two *journals* on the ends of the shortest piece, two and a half inches less in diameter than the block will be when made perfectly round. If he has a turning lathe he will be able to do it all in a couple of hours. Let him make the axles or journals seven inches long each. You have now one roller finished ; the other is like it, only after making a journal on one end, he measures along the same length as the other roller, which

will be sixteen inches, and then cuts *into* the block another journal like the others, leaving beyond it eighteen inches of sound wood to spare, of the same girth or diameter as the roller part. Through this eighteen inches that you have left over, cut a square hole or socket, large enough to put a good stiff wooden lever in or through it, so that when your rollers are set up on end in a frame, like a windlass, you can walk round with the lever, and so turn the mill. If there is a blacksmith in the neighborhood, it would be well to get him to put an iron hoop above and below the lever hole or socket, to prevent the strain, which will be considerable, from splitting the top. You have now the rollers complete; the next step is to make the frame that holds them together. Take two pieces of timber, nine feet long and nine inches square, if you have them; if not, round, barked timber will do; dig two holes in the ground six feet deep and four feet apart wherever you wish your mill to stand. Put the posts into them, and fill the earth in again, beating it down so as to hold these uprights as stiff and immovable as possible. These are the supports of your mill, and have to bear all the strain, so you must see that they are strong and firm. Now, get a slab of wood, six feet long, sixteen inches broad, and eight inches thick, set your two rollers on it, standing upright, and close together; mark the two holes for the lower journals, and cut them out six inches deep. You must now cut a couple of notches at the ends of the slab, fit these notches between the two posts, and pin them tight. Now you have the bed plate of your mill. Set the rollers upright on it, with the journals in the holes you

have cut for them, and proceed to fit the upper frame plate in the same way, except that it must be made in two halves, owing to the socket part where the lever goes preventing your slipping it over both journals, as was done in the other case. For the upper frame plate, taking two pieces, six feet long, nine inches broad, and seven inches thick, fit them nicely together round the journals, and fix as before. To keep the two pieces from spreading when the strain comes, either clamp them together with wooden clamps and wedges, or hold them together with a dovetail tie. The mill is now complete; put in the lever, and you are ready to crush the canes. Cut a small gutter round the roller in the wood of the bed plate, leading to a spout, to prevent the juice from running all round and being lost. The above need not cost a farmer ten dollars where wood is plenty, is sufficiently strong, and will crush a hundred gallons of juice per day, if required.

Of course, it will be understood that a mill like that described above, is merely a make-shift for experimenting with, for you could only get one half the juice by it, that an iron one of the same construction would yield. Another mill, of simple construction, is figured on the following page, and is the one used by Colonel Peters in his syrup making experiments of last season. Instead of being made of wood, the rollers are cast iron.

CRUSHING OUT THE JUICE.

Having brought your canes to the mill, and adjusted your lever, either let a man walk round with it, or attach a horse or pony. Pass the canes through, two at

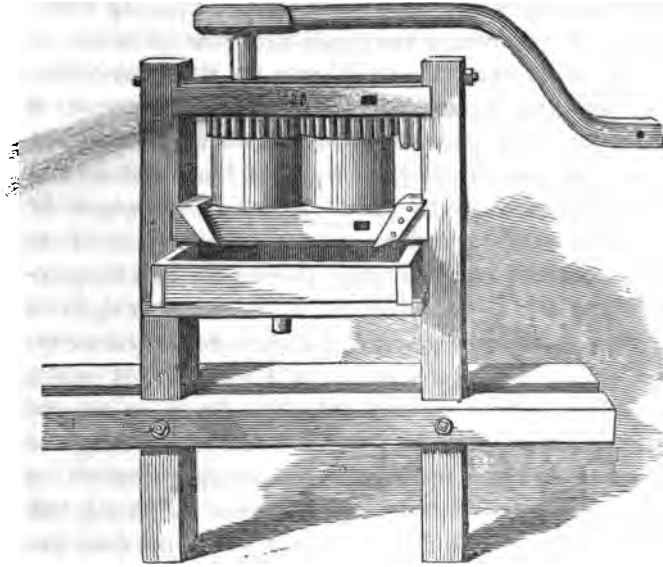

a time, till you have sufficient juice for a boiling, say ten gallons or fifteen gallons ; which should be crushed out in half an hour. Now build a fire-place with stones, or set up two forked poles, and put another across, on which sling your pot, which may be of sheet tin, but had better be of cast iron. Let it hold, say ten gallons. Get a small tin skimmer at a tinsmith's shop, and you are prepared to commence boiling.

BOILING AND CLARIFYING.

Everything being ready, slack a teacup full of lime, mix it to the consistency of cream, and set it by for use. Light your fire, with charcoal if you have it, for it makes

no smoke, but if you have none, use dry kindling wood. If possible, so arrange your rude fire-place as to let the fire reach no more than half way up the sides of the pot. Put five or six gallons of juice into the pot, set it on the fire, and when it becomes milk warm, add one large tablespoonful of the cream of lime, and mix it thoroughly through the juice. Now take the whites of two fresh eggs, beat them up with a teacupful of *the juice* from the pot, and when thoroughly mixed, pour back, and stir them well through the mass, bring it to the boil as soon as possible, *but the moment you see the first signs of boiling, lift the pot off the fire*; set it on the ground, and let it remain quiet for fifteen or twenty minutes. You will have perceived that after adding the cream of lime and eggs, as the simmering went on, a thick scum began to rise; *this you must not disturb*, but allow to gather on the top, till you take the pot from the fire as directed, and allow it to settle fifteen or twenty minutes. At the end of this time, carefully remove the scum, and you will find if you have carefully followed these directions, that the juice has become clear and bright, ready to boil down to the consistence you require, whether of syrup or sugar. Having removed the scum, empty the contents of your pot into some clean vessel, which have convenient. Fill up your pot again with the raw juice, and proceed as before. This is the process of clarifying or *defecating*, and is absolutely necessary, if you do not wish to have a dark, dirty syrup, tasting of cane stalks, and almost unfit for use.

After clarifying and skimming the second pot full, as directed, set it back on the fire, and boil down as rapidly

as possible. As the quantity reduces by boiling, keep adding fresh juice from the first clarification, so as not to let the syrup get too low in the pot, or it will get burned. If any scum rises, remove it with your skimmer; and by following these directions, you cannot fail to make good syrup.

The preceding remarks suppose that you have only *one* pot to operate with; but it is very much better to have two, as it will save twenty minutes' time, and fuel, with each kettle of syrup you make; because, as I have shown, you have to wait twenty minutes after taking the pot from the fire, to allow the scum to rise and settle; so, if you have not another pot full of fresh juice to put on, it is so much time and fire wasted. With two pots in use, you replace the first on the fire as soon as you take the other off, and proceed to boil down.

SYRUP OF EXTRA QUALITY.

Should you wish to make a very extra syrup for table use, get a flannel bag, of almost any shape, sufficient to hold two or three gallons, and filter the juice through it after you have skimmed it, then boil down as before.

HOW TO KNOW WHEN THE JUICE IS BOILED ENOUGH.

It is a matter of importance with those who have never boiled syrup to know when the juice is boiled enough. There being nothing like experiments, I would advise such to procure a cup full of molasses, heat it, and taking up a small quantity on a spoon, to watch how it runs

down, and when the drops come, how they elongate and break in the middle, the upper half springing back with a jerk, and the lower forming a ball and falling into the cup again. Three cents in money, and the expenditure of five minutes' time in this way, will go farther in educating the eye to a good judgment, than an elaborate series of directions.

I will give one other method, however, of knowing when syrup is cooked enough. Dip your skimmer into the boiling liquid, take it out and allow the syrup to run off it; a few drops will remain on the edge, falling at intervals. If these break with a long string between, which at the break jerks back to the dipper again, and which when taken between the finger and thumb feels *like molasses*, it is fair to suppose your syrup is sufficiently boiled, and you may take it from the fire.

REDUCING TO SUGAR.

For making sugar, it will be necessary to boil this same syrup down till the steam escapes from it in little puffs, and when the skimmer is dipped into it, the falling drops break short and fall solid. These simple tests, and perhaps a few failures, will enable one to make good sugar. When enough has been boiled, pour it into a wooden box or tub to cool slowly, standing it in a warm place. Let the box be large enough to allow of the sugar standing only $1\frac{1}{2}$ inches deep; boil another lot, and pour over the top of the first, and a third over the top of the second, mix them all together, and allow the contents to cool. If, by the next morning, there should

be no signs of crystals, take a handful of raw sugar and stir it in; in all probability it will start crystallization; but if it should not do so immediately, do not despair, for it may stand for an entire fortnight, and then suddenly *strike* into sugar.

The above simple and valuable directions have been kindly furnished for this work by an experienced sugar boiler, and will recommend themselves to those who desire to experiment in sugar making on a limited scale.

To give my readers some idea of the amount of capital requisite to carry on the operations of a large sugar plantation in the State of Louisiana, I will, in concluding this chapter, append the following extract from a valuable article, written by my friend, Colonel T. B. Thorpe, for the November, (1858,) number of Harper's Magazine:

REFINERY AND PLANTATION OF ST. JAMES.

"The tract of land connected with this estate, contains nine thousand acres, one thousand five hundred of which are under cultivation, and divided as follows: eight hundred acres in cane; two hundred and ninety-four acres in corn; one hundred and fifty acres cultivated by the negroes for their own use; ten acres in olives; the remainder of the fifteen hundred acres alluded to as under cultivation, is taken up by potatoes, building lots, pasturage, and gardens: remainder of the nine thousand acres is in forest, from which is taken the fuel consumed in manufacturing and refining, and the timber for the casks used in packing the sugar for market.

"The buildings consist of the proprietor's dwelling

repairs of machinery and buildings. The weekly rations and out-houses; twenty-four negro houses, with verandahs in front, each cabin is forty feet square, and contains four rooms, and has a garden and fowl house attached; a hospital sixty-four feet square, containing seven rooms, and an immense verandah; a nursery fifty feet square, store-houses, overseer's or manager's house, stables containing one hundred stalls, two wood houses, each four hundred feet long by one hundred wide; one sugar house five hundred and seventy feet long, by seventy-five feet wide, thirty-four feet high between the floor and ceiling; and a 'double saw mill.'

"The machinery consists of steam saw mills and pumping engine at the river for supplying the sugar house with water, steam engine of eighty horse power, and sugar mill for grinding cane; engines, vacuum pans, and a complete apparatus for making and refining twenty-five thousand pounds of sugar every twenty-four hours direct from the cane juice, and doing this entirely by steam.

"The stock upon the plantation consists of sixty-four mules, twelve horses, sixteen oxen, one hundred and forty-five sheep, eighty head of cows and 'beeves,' two hundred and fifteen slaves—among which are one hundred and seven field hands, two coopers, one blacksmith, two engineers, four carpenters, twenty house servants, four nurses, eleven old men and women that attend to the stables, and sixty-four children under five years of age.

"The cash expenses of this estate are twenty thousand dollars annually, paid to managers, sugar-makers, engineers, and for food and clothing for the negroes, and

of each negro are five and a half pounds of mess-pork, best quality, with as much meal and potatoes as they choose to take—in addition to which every one has his pigs and his poultry; for all adults have not only the chicken-yard, but also their garden, which they are obliged to cultivate for their own benefit—the surplus of vegetables and poultry being purchased by their master, and paid for in gold and silver, and amounted, in the year just past, to one thousand five hundred and sixty dollars—this sum not including the money obtained by sales of poultry, pigs, eggs, and fruits, to chance customers. In addition still, the negroes annually receive two suits of clothes, two pairs of shoes, a blanket, and hat.

“The value of the estate of St. James, and of its productions for the year 1852, are as follows :

VALUE OF THE ESTATE.

Land, 9,000 acres, at \$40,	-	-	-	\$360,000
Buildings,	-	-	-	100,000
Machinery,	-	-	-	60,000
Slaves,	-	-	-	170,000
Stock,	-	-	-	11,000
				<hr/>
Total,	-	-	-	\$701,000

PRODUCTIONS OF THE ESTATE IN 1852.

Sugar, 1,300,000 lbs., at 6 cts.,	-	-	\$78,000
Syrup, 60,000 gallons, at 36 cts.,	-	-	21,600
			<hr/>
			99,600

Brought forward,	-	-	\$99,600
Corn, 9000 barrels for consumption on the estate; wood: 8000 cords for the engine house.			
Estimated value	.	-	14,400

Total products of the estate, - \$114,000

“This plantation shows the average production of the best class of sugar estates in Louisiana, the largest of which, in 1852, yielded a revenue of one hundred and fifty-two thousand and fifty dollars; but these estates increase the value of their products by the aid of costly machinery, not used on the ordinary plantations.”

This article being written four years ago, does not, of course, give a true idea of the profits of the same estate the present season; for, whereas the running expenses of the estate are about equal to the above, the prices of sugar and syrup have greatly increased, and the gross receipts must be by so much the same augmented.

THE NEW SUGAR MILL OF MESSRS. HEDGES, FREE, & CO.

Messrs. Hedges, Free, & Co., of Cincinnati and Philadelphia, who so kindly forwarded to me the pamphlets received by their house from the Honorable John Y. Mason, and which have proved so extremely valuable to the elaboration of this work, have recently invented a three roller vertical mill for expressing the juice of the sorgho and imphee, and in reply to a request to furnish cuts to illustrate this work, I received the following:

“PHILADELPHIA, August 14th, 1857.

H. S. OLCOTT,

DEAR SIR,—In reply to your inquiries as regards our mills, boilers, &c., for the purpose of expressing and concentrating the juice of the Chinese and African Sugar Canes, we take pleasure in saying that the cut we send you represents our vertical three-roller horse-power mill, that has met with very ready sale here, and at Cincinnati, Ohio. They are so simple of construction that they can be set up in a single day by two hands, and are provided with a convenient arrangement for feeding, so as to spread the cane over the whole length of the roller equally, causing it to pass through in a direct horizontal line—a desideratum never before attained, but very essential to horse-power mills. As we construct our mills with iron frame work entirely, we have not only strong ones, but durable, and free from the bad effects that must result where the juice comes in contact with woodwork. We have mills differing in capacity, of the same general construction, but greater length of roller. For steam-power we furnish mills, with horizontal rollers, arranged upon the approved plans of such mills.

“Our mills vary in prices from \$100 to \$500.

“We are prepared to furnish pans, clarifiers, filters, ladles, skimmers, and all other apparatus and fixtures, with diagrams and instructions complete.

“Those west of the mountains order from us at Cincinnati, Ohio; those east, from this city.

“HEDGES, FREE, & CO.,

“Office, No. 633 Market Street, Philadelphia.”

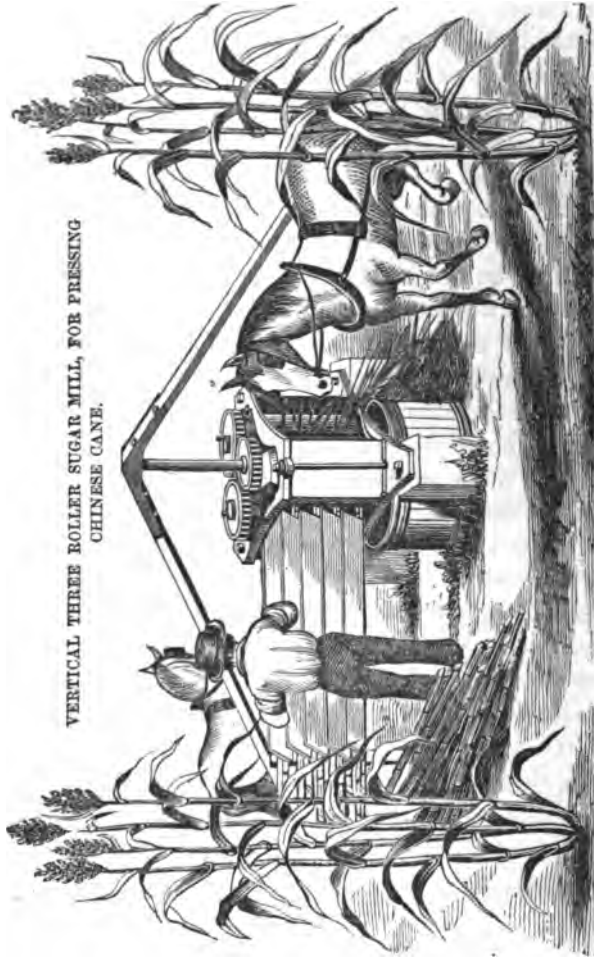

VERTICAL THREE ROLLER SUGAR MILL, FOR PRESSING
CHINESE CANE.

For the more extensive operations of planters, Mr. Hedges has constructed a more powerful mill, a representation of which is given herewith.

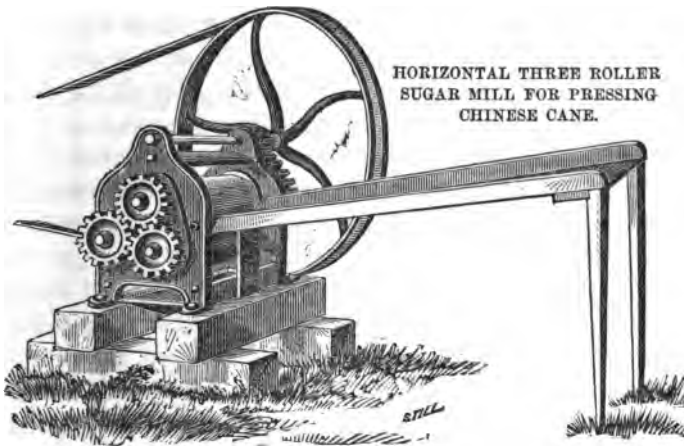

MACHINE FOR STRIPPING THE SEED.

The following plan for a seed-stripping machine, offered by Mr. Hedges, is doubtless a close approximation to what is needed :

“ For cleaning the seed, we would recommend the use of a cylindrical hatchel, or hackel, (often used for broom corn,) made of staves turned upon wooden heads, about two feet diameter, and of a length to suit the amount to be done and power to drive it. For teeth, use large wrought spikes, set through the staves before putting on the bands. These teeth may be about three inches apart, and so distributed as to cover the whole surface in re-

volving; cast-iron flange, with stem for journal and crank, bolted on the heads; finish cylinder—one four feet long would, if turned by two hands, clean fifty to seventy-five bushels per day. A plank breastwork should be set up for the cleaners to rest their hands on while grasping as much as convenient to hold, and the cylinder rolling over from them will strip off rapidly all the seed. This should be done before the boiling is commenced, so that the seed can be mixed into the hot scum taken from the clarifier and kettles, which combined, will fatten hogs or cattle, beyond doubt, more rapidly than any other feed known. The starch in the seed, added to the sugar in the scum, must constitute capital food. Should there prove to be a surplus, it may be preserved for a considerable time in cisterns well cemented and deep, where fermentation will be slow; but the mass must be allowed to get cool before being put in. Such cisterns will become useful for storing the syrup, should it prove profitable as an alcohol crop, as they would be cheap and safe repositories for it until the season and market demanded it, when it could be raised by pump, and with one set of casks, hauled away and emptied, returned, and refilled, thereby saving much expense for casks. In this manner I learn syrups are often kept in the large sugar districts of the West Indies."

CHAPTER VI.

SYRUP.

BEST METHODS OF MAKING IT—EXPERIENCE OF AMERICAN GROWERS.

WHILST contending chemists have alternately sung the praises of, and decried against, the sorgho as a sugar producing plant, and opulent sugar refiners have trembled at the threatened invasion of their accustomed monopolies, all have united in the opinion that it is indeed a plant capable of affording an abundant and excellent crop of syrup.

The American public received a most unexpected and agreeable surprise in the month of October last, by the publication of a circular from Colonel Richard Peters, of Atlanta, Georgia, which gave the remarkable results he had obtained in making syrup from the juice of the sorgho. So complete, so triumphant was his success, and so full was it of magnificent promise for the future, that with one accord it was caught up from press to press and scattered to every quarter of the Union. The papers of Maine and Texas, of Maryland and Utah, discussed its probable importance, and with but little delay Mr. Peters became one of the most widely known men of the country. The result was, that from that day to this, he is in the receipt of a vast number of letters of inquiry, and in self-defence was obliged to issue a pamphlet of directions for

the cultivation of the plant and manufacture of its syrup. He has, besides this, he informs me, written a thousand or more letters of reply. Samples of his sorgho syrup were given to him by a number of persons in all sections of the country; and amongst others, a keg of it was kindly sent to myself.

The success of Mr. Peters being made known early in the season, induced many farmers in the northern and north-western states, who had small patches under cultivation, to endeavor to make a little syrup themselves; and in no case, so far as I have seen reported in the public papers, was the attempt unsuccessful. By personal correspondence, I know of syrup having been made in thirteen states and territories. And I doubt not that Mr. D. Jay Browne, and Colonel Peters, could add considerably to the list.

As might have been expected, when we consider the rude method employed in expressing the juice and boiling it, the syrups in some cases were of questionable excellence; but where more care was taken, the most gratifying results were attained. Colonel Peters' syrup was boiled in a common iron "cow-pot," and from inexperience or carelessness of the hands employed in the operation, it was not only suffered to become scorched, but it was not properly neutralized with alkalis, and kept from exposure to the air. Another reason for its imperfect quality was, that the barrel from which the specimen samples were taken, was made from frosted canes. In fact, so imperfect was it compared to what it might have been, that, judging from its quality, Mr. Peters is now convinced, that if he but takes ordinary

precautions with this season's crop, he will be able to make a syrup worth one dollar per gallon. The syrup which we made at our own place, was of better color and superior taste to the Georgia specimen; and I have seen samples from other states, which much surpassed our own. One, especially, made by Mr. Boylston, Editor of the "Amherst Cabinet," New Hampshire, was equal, if not superior to Stewart's syrup.

Doctor A. A. Hayes, of Boston, one of the Assayers to the State of Massachusetts, told me, recently, that he was convinced that excellent syrup could be made from the sap in considerable quantities. And at a recent meeting of the Farmers' Club of the American Institute, Doctor Charles T. Jackson, of Boston, the associate Assayer with Dr. Hayes, said "the syrup of this new sugar plant, properly refined, and mixed with a small per centage of honey, is equally delicious as honey from the hive." This gentleman informs me, that the specimens made by him from the canes furnished by the General Government, were completely colorless.

All these facts go to prove that the best results are always obtained by careful management, and whilst the climate and soil of various localities doubtless exercise no inconsiderable influence, yet we may rest assured, that either at the North or South an intelligent and experienced operator and a suitable apparatus, will always command greater profit and better quality of product, than a shiftless experimenter.

THE SEED MAY BE GATHERED WHEN GROWN FOR A SYRUP CROP.

It has been sufficiently well proved that the ripening of the seed of the sorgho does not interfere with the extraction of the full richness of the saccharine matters in the juice, and the farmer who is desirous of growing enough of a crop to make the molasses for his family use, will be furnished with a further inducement to do so from the fact, that at the same time he can be cultivating a prolific crop of seed for feeding to his poultry, and a large amount of green forage, in the leaves, for his horses and stock.

APPARATUS NECESSARY.

To persons who merely desire to make a few gallons of syrup for their family use, a complete apparatus is not of paramount importance; but if it is in contemplation to duplicate such extensive practice as that of Mr. Peters, it will be a matter of positive economy to procure a mill and boilers that will extract the greatest possible amount of sap from a given quantity of stalks. The juice last expressed from the cane is the richest, and it is therefore desirable to procure a mill of sufficient strength to extract nearly the whole sap. Small farmers and planters can, of course, only approximate to this end, because of the great grinding capacity and very large expense of the more powerful mills; but I do not think that a farmer, with a crop of only five or ten acres, should use a wooden roller mill when he can procure one with iron rollers for twice or thrice the money. The canes of the sorgho are

hard, both because of being so very full of sap, and from the large quantity of silex in their outer coating; and a wooden roller mill could scarcely be depended upon to last through a season without breaking, or, if it should, the rollers would most probably be crushed and badly indented by the hard canes. Another argument in favor of iron rollers is, that the saccharine juice of the sorgho, when taken up by the pores of wood, is exceedingly likely to become sour, and thus injures the portions of juice successively passing through the mill.

M. D'IVERNOIS' SYRUP.

It is possible to make syrup from the sorgho without the use of any mill or crushing apparatus whatever. Thus, according to an article by M. d'Ivernois, translated from the Bulletin of the Imperial (French) Acclimation Society, by Hon. H. Meigs, Secretary of the American Institute, all that is necessary is to select the butts of mature stalks, cut them into pieces of about an inch in length, and boil them in pure water in an iron pot. When the water has become charged with the sweet juices of the cane clippings, it should be strained off and clarified in the usual way, with a little cream of lime, whites of eggs, bullock's blood, or skimmed milk. After another boiling, to reduce it to proper consistency, it may be put into stone jars or pots and tightly covered, like ordinary preserves. This practice is at best an imperfect one; for, not only is the saccharine matter in the stalks boiled out, but, at the same time, all the other soluble,

organic matters, such as wax and chlorophyl,* which impart a disagreeable taste to the syrup.

IRON ROLLERS BETTER THAN WOODEN ROLLERS.

An idea may be had of the imperfection of Colonel Peters' mill, when we reflect that whilst with it he obtained but fifty per cent. of juice; Dr. Robert Battey, by pressing and subsequent evaporation, got 84½ per cent. of sap and only 15½ of woody fiber. It is found by numerous experiments, that with proper machinery, seventy per cent. should be obtained as an average product, and when we consider that with only fifty per cent. Mr. Peters actually worked up an average crop of 407 gallons of syrup per acre, my reader will doubtless agree with me that the difference on a single acre between the syrup from *thirty* or *forty* and *seventy* per cent. of sap would more than warrant the substitution of an iron roller for a wooden roller mill.

AMOUNT OF SACCHARINE MATTERS VARY IN DIFFERENT CASES.

The different writers on the sorgho, who have experimented with the sap, give various accounts of its richness.

* This *chlorophyl* (green coloring matter) injures the quality of the juice expressed from the sorgho in the large processes of manufacture, and therefore as, both in the West Indian Cane and the Chinese Sugar Cane, the greater saccharine richness lies in the lower parts of the stalk, those nearest the butt, it is advisable to cut off about two and a half or three feet of stalk, when the seed heads are removed; and all the leaves of stalks intended for sugar or syrup making should be removed.

Thus, a sample grown near Washington gave Mr. Browne fourteen per cent. of dry saccharine matter, but another from the Arsenal, near Boston, yielded twenty-three per cent. Vilmorin's proportions varied ten to sixteen per cent. Dr. Turrel's from ten to twenty. Mr. Wray's imphees sixteen per cent. of sugar. Mr. Avequin's, in Louisiana, was a little over ten. The densities were also different. Dr. Battey, of Georgia, found his superior to Vilmorin's, the latter ranging from 1.050 to 1.075, whilst the former's uniformly stood at 1.085. Avequin's was 1.064, reaching almost to 9° Beaumé. Mr. Hardy's, in Algiers, stood at 8 $\frac{3}{4}$ °.

If we accept even the lowest per centage shown above, we still shall have a sacchariferous plant much superior to the sugar beet, which in 1854, in France alone, employed three hundred and thirty-two manufactories, producing 158,000,000 pounds of sugar, besides molasses. In this same year (1854) there were consumed in the United States over fourteen million gallons of molasses, which, at thirty cents, cost us \$4,200,000, and as we approach the threshold of 1858, the price is doubled. Who, then, will have the temerity to say that even if the sorgho had not proved its capacity to furnish good, crystallized sugar, that as a molasses-producing plant, it would not have proved a source of vast wealth?

SYRUP BOILING.

The process of reducing the sap to the consistency of syrup, is so simple as scarcely to demand very protracted instructions. The farmer, having cut his canes as near the ground as possible, stripped off the leaves and remov-

ed the tufts, carts them to the mill as fast as he can conveniently grind them. The juice runs through a tin pipe into a tub, or box, painted on the inside, or a large wooden reservoir, lined with tin, lead, or sheet copper, either of which should at all times be kept scrupulously clean. In this, those only using Mr. Wray's patent can add the lime to clarify the juice *in the cold state*, and from thence pump or bail it into the boiler, where, as the heat rises to from 120° to 180° Fah., the dilute infusion of powdered nutgalls is introduced. The syrup is then carried to the boiling point, when the fire is at once checked, the syrup stands for about fifteen or twenty minutes, to give the scum a chance to rise and be skimmed off; the fire is then urged again. The syrup then is kept boiling until reduced to the proper consistency. This precise degree is ascertained by the insertion of a little glass or metallic instrument called a "syrup guage." These may be had of Messrs. Pike and Son of New York, opticians, or Mr. Jno. W. Reid, or any other respectable sugar-apparatus maker. My friend, Dr. Robert Battey, has prepared a syrup guage, on which he has marked but *one* degree, and it is thus rendered so extremely simple that any farmer, or farmer's laborer, can always tell the exact moment of its arriving at the "proof point." The drawback to it is that it is made of glass, and is thus liable, unless securely packed, to be broken in being transported, and when in use, otherwise the idea is an excellent one.

For the benefit of such as do not wish to purchase the right to use Mr. Wray's patent, which all should, I subjoin the directions given by Dr. Battey in Mr. Redmond's pamphlet:

BOLLING DOWN.

“The fires should be so arranged that they may be under good control, to be forced or withdrawn, as occasion may require. When the juice is placed in the boiler, the fire should be gradually increased to a simmering heat, (not to active boiling,) and maintained at this temperature until a thick green scum rises to the surface, and forms into puffs, seeming ready to crack. This scum, when fully formed, should be removed clean from the surface. The heat may now be raised to boiling, and kept in an active state of ebullition until the bulk is reduced one half. The fire may be removed from one kettle, and its contents be transferred to the other, when the heat must be gradually moderated, as the syrup becomes more concentrated, to avoid the danger of scorching, which injures the color and flavor. Should more dirty green scum rise to the surface after the first skimming, it should likewise be removed.

“In regard to the precise degree of concentration to which the syrup should be brought, it is exceedingly difficult to lay down any precise and simple rule which shall meet every case. The plan for determining it, in use on the sugar plantation, and which was adopted by Governor Hammond and Mr. Peters, is based upon the judgment of the eye, in respect to the consistence of the syrup, when poured from the ladle, and cooled as it drops from its edge. This test is evidently very defective, since the temperature of the atmosphere regulates the consistence which the syrup must assume on cooling down—so that a syrup boiled on a cold day will necessarily be thin and

watery as the weather moderates, and a syrup finished at night will differ materially from that of the noon-day. Although a good approximation, it is not exact enough for the tyro—to secure a desirable uniformity in the consistence and value of the product, or to obviate the danger of fermentation and loss. To remedy this uncertainty, and secure a uniform result at all times, I have constructed a simple instrument which determines readily, and with certainty, the precise moment when the syrup should be removed from the fire and transferred to the barrels.

“It is a prevalent opinion that lime should always be added to the juice, as soon as it is pressed out, and the idea has been advanced that it could not be clarified without lime. This is undoubtedly a mistake; the juice alone, under my hands, clarifies itself more readily without lime than with it. The latter answers no useful purpose, so far as the syrup is concerned, save to neutralize the free acid (phosphoric) which exists naturally in the cane. Lime darkens the color, and, to my taste, detracts from the peculiar grateful flavor of the syrup. Many would, perhaps, object to the slight acidity. To such I would say, use the lime, but use it sparingly. To prepare it for use, take a half peck of lime, slake it in a bucket of water, gradually added, stir up well, and strain the milk through a cloth; let it settle for half a day, pour off the water and dry the powder. Of the latter, you may use from half a teaspoonful to two teaspoonful for every five gallons juice, after the scum has been removed.”

NECESSITY FOR CLEANLINESS AND SYSTEM.

One requisite to ensure the production of good, clean syrup, is that the greatest cleanliness should be observed throughout every stage of the manufacture. The mill, boilers, ladles, buckets, troughs, reservoir, and every piece of apparatus, and each implement used in the syrup making should be cleaned off as soon as they are no longer in actual use. The canes should be stripped clean of all dry or green leaves, and when convenient, any lumps of dirt or other impurities be knocked off, before the canes are passed through the mill. Only ripe and sound canes should be used; and the ground about the mill should be neatly swept, and all rubbish removed. If the boiling is done under a shed, or in a building, it should be as neatly maintained, and all things should be as systematically arranged as if it were a private parlor; for not only is the introduction of impurities into the syrup prevented, but the operator and his assistants can, at the desired moment, at once lay hands upon any one of the instruments needful at the various stages of the operation.

COLONEL PETERS' RESULTS.

The yield of juice and of syrup obtained by Colonel Peters, were as follows:

BEST EIGHTH OF AN ACRE.

Yield of juice from 3315 canes,	-	-	253 gallons.
Yield of syrup from 253 gallons juice,	-		58 gallons.
Rate of syrup per acre,	-	-	468 gallons.

POOREST EIGHTH OF AN ACRE.

Yield of juice from 2550 canes, - - -	179 gallons.
Yield of syrup from 179 gallons juice, -	43½ gallons.
Rate per acre, of syrup, - - -	346 gallons.

Weight of thirty select canes, - - -	49½ pounds.
Weight of juice pressed out, ' -	25½ pounds.
Weight of crushed cane, - - -	23 pounds.
Loss in crushing, - - -	¾ pounds
Weight of crushed cane dried in sun, -	9½ pounds.

Or, in other words, he made an average crop, *four hundred and seven* gallons of syrup; and even then obtained only five sevenths of which he actually should, if he had been in possession of perfect machinery.

With such results as these for consideration, how fortunate, nay, how *providential* must it seem, that just as short crops, combination of capitalists, and increase of consumers threaten us with an alarming advance in the price of an article which is no longer a luxury, but a necessary of life, a new sugar plant is given to us, of such prolific resources as this Chinese Sugar Cane.

CHAPTER VII.

ALCOHOL.

ITS IMPORTANCE AS AN ARTICLE OF MANUFACTURE.

ALCOHOL, at the present day, occupies a very important place in the domestic economy of every family ; not, it may be, in the form with which it comes to us from the distillery, but disguised under the familiar cognomen of many articles in daily consumption, it performs its useful functions, unchallenged and unsuspected even by the members of the Temperance Society.

In the *materia medica* we are indebted to it for chloroform and ether, and many of our most valuable vegetable extracts and essences could not be obtained without it. In the arts we require its aid to dissolve the refractory gums and resins ; while in the shape of camphene, or spirit gas, it yields, with other ingredients, a brilliant and economic means of illuminating our dwelling-houses and workshops.

It is true that alcohol, in its *abuse* as a beverage, is the cause of much individual suffering from time to time ; instances of this, however, are small compared with the universal benefit which it affords ; and seeing that it is not in the light of a beverage exclusively that I mean to treat of it, but also as an important item in our national economy, I trust that even the most fastidious will hold me blameless if, in the course of my remarks, I endeavor

to impart to others what little knowledge and experience I may possess in regard to this most important manufacture.

THE CEREALS NO LONGER NEED BE EMPLOYED TO MAKE ALCOHOL.

Hitherto molasses from the cane, and the cereals, corn, barley, and rye, have furnished the bulk of the spirit so extensively needed, but a new era seems about to dawn upon us; the cereals may return to more legitimate channels of consumption, while a new plant, useful it would seem, besides, for other purposes, supplies their place—the discovery of which, and introduction to our country, deserves to be classed among the most important events of the age, while every endeavor ought to be used to develop, rather than to retard, through a mistaken and narrow-minded philanthropy, its application to the manufacture of spirit, which, I have shown, has now become an article of large consumption among us.

WHAT IS ALCOHOL? HOW MADE?

Alcohol may be termed, practically, *pure spirit*, the result of vinous fermentation in certain bodies capable of assuming this condition, from which it is obtained by distillation. A few of these bodies are wine, cider, beer, and cane juice. When either of these liquids has undergone the vinous fermentation, and is subjected to vaporization in a close vessel with a suitable condenser, alcohol is obtained as a result, more or less pure according to the apparatus employed and the skill of the operator.

Rum, gin, brandy, and whiskey, are nothing but alcohol more or less dilute and flavored with the essential

oils, which give them character. Thus rum is alcohol flavored with the essential oil of the sugar cane; gin with the oil of the juniper berry; brandy with the oil of the grape; while whiskey owes its peculiarity to the well-known fusil oil inherent in grain. By depriving either of these liquors of the essential oils, coloring matters, and volume of water they contain by means of rectification, we obtain from them pure alcohol, or the well known *spirit of wine* of the apothecaries' shops.

To obtain *absolute alcohol*, or a spirit perfectly free from water, is impossible by any of the distilling apparatus yet invented, alcohol having too great an affinity for water, to be separated entirely by mechanical means. Yet a spirit sufficiently pure for all commercial purposes may be produced by a variety of distillatory arrangements, which it shall be my duty to refer to in the proper place. Spirit containing only five per cent. of water may be manufactured by a good apparatus.

It being the purpose of this work to treat only of the sorgho and its products, it is to the manufacture of sorgho spirit only that I shall refer. But as in the case of the manufacture of sugar from the same source, I considered a description of a West Indian plantation and apparatus best calculated to elucidate the subject, so, as regards the manufacture of sorgho rum or spirit, a short detail of the methods practiced in Cuba and the Windward Islands, together with a few illustrations of improved apparatus, will best serve the purpose, feeling assured—judging from a sample of sorgho syrup received from Mr. Olcott—that the products of the cane and sorgho are alike, and required similar treatment to obtain like results.

Distillation being an operation which requires preparation in the fluid to be operated upon, before proceeding to distil we must first understand how to prepare the *wash* so as to obtain the largest amount of alcohol from a given amount of sweet liquor. Where grain is the substance employed to form the *wort* or *wash*, the manipulations are complex and various, requiring long experience to understand thoroughly ; but when, as in the present case, the fluid is already in a forward state of preparation, by reason of its nature, and requiring to undergo but one preparative operation previous to distillation, the subject becomes simplified, and less difficult to describe or comprehend.

FERMENTATION.

To produce the vinous or alcoholic fermentation in a fluid, it is a first requisite that that fluid be *sweet*. This sweetness may either be the result of chemical combination, brought about by art, as in the case of worts made from grain, or it may be the natural condition of the fluid, as in the case of the expressed juice of the sorgho.

When fermentation takes place, several phenomena not to be mistaken make their appearance. The juice seems to boil, minute globules of carbonic acid gas come to the surface, like the effervescence of champagne when viewed through a glass, the temperature rises several degrees above that of the atmosphere, an aromatic, *rummy* smell is evolved, and a scum of yeast gathers on the top. To the tongue, the previous sweet flavor has given place to a slightly acid, pungent taste, and when the fermentation

has been brought successfully to a close, the wash, which before fermentation was commenced marked 8° to 10° Beaumé, will now be found to mark little over 1° Beaumé, showing that nearly all the saccharine matter has been changed into alcohol. If left twelve hours after this, the acetic or vinegar fermentation commences, and the alcohol gradually disappears, to the serious loss of the distiller.

In the West Indies, the mixture of the materials, or what is termed *setting* the wash, varies with the season. When crop has just commenced, or just finished, it is different from what it is in winter, as the rainy season is called; besides, the scientific distiller varies his mixtures to suit circumstances. The same proportions that are suitable for one state of the atmosphere may be unsuitable for another, and it is the capacity to judge what is best for the season that constitutes the *valuable* overseer to the still house.

Owing to its liability to conflagration, the still house is generally set apart, but in the vicinity of the boiling house, so that too much labor may not accrue from having to carry to it the scum of the kettles and molasses for conversion into alcohol.

If the still be a small one, the planter usually contents himself with a mere shed for a still house, and a few rum puncheons, with a square hole cut on the side where the bung-hole has been, for fermenting vats. But if rum is intended to be one of the regular products of the estate, the matter is gone into more carefully. A regular stone still house is built, and proper fermenting tuns of oak or white pine provided.

The still house is generally of two stories, each pretty high; the second story consisting of a floor extending up to the place where the still is set. Here it is cut away, and the space is left clear from the ground to the roof; this is to allow of the various appurtenances of the still being elevated to the proper height, free from obstruction from joists or other interferences.

In extensive distilleries, however, such as that of the Messrs. Belchers, in Matanzas, Cuba, the still house is of several stories, and special arrangements are made to suit circumstances. Here as many as thirty or forty large fermenting tuns are employed, each capable of containing from two to three thousand gallons, so arranged that no more of the *mosta*, or wash, shall mature each day than is capable of being distilled within twenty-four hours.

Underneath the ground floor of the still house a mixing tub ought to be placed, and grated over with a wooden grating level with the floor, so that a molasses puncheon may be rolled over it, the bung taken out, and its contents let down through the bars, to save labor. This tub or vat ought to contain a charge for one or more of the fermenting vats employed. The mixture of the ingredients for fermentation is made in it by agitating them together by means of wooden rakes or oars. When completed, the wash is pumped up into the fermenting tubs, tuns, vats, or backs, as they are called irrespectively according to local usage, where it undergoes the vinous or alcoholic fermentation, and in turn is distilled into rum or low wines. As many as twenty pipes of rum, of one hundred and twenty gallons each, are made on some large estates each day during crop.

So far the arrangements of West India still houses have proved appropriate and applicable to the distillation of the sorgho, but here the applicability ceases ; for the West Indian mode of setting the wash, and the time allowed for fermentation there, is quite unsuited to the variety of the cane family we are at present considering. I will, therefore, now proceed to describe the process best suited to the new plant, so as to obtain the best results, taking my data from the various French reports which have been made on the subject.

THE ALCOHOLIZATION OF THE SORGHO.

In France there have been quite a number of experiments made on the conversion of the sweet juices of the sorgho sucré into various liquors, such as rum, brandy, wine, and beer. We find Vilmorin in 1854, Alphanbéry in 1855, Bourdais, Sicard, and Madinier in 1856, and Detur in 1857, publishing reports on the subject, to which I shall refer.

Alphanbéry reports that he made very good brandy by concentrating the juice of the sorgho slightly (12 B.?) and putting it into a barrel, where it fermented a week, then distilling it. The eau de vie, says he, thus obtained, is incontestibly superior to that made from wine (real brandy.) Also, that if some of the juice be taken during fermentation, and bottled close, it makes a very agreeable drink.

It is evident from the above that the circumstances under which M. Alphanbéry fermented his juice were unfavorable, as the sorgho almost always, when properly

cared for, finishes fermentation in three days at most. Nevertheless, his testimony is valuable as to the *quality* of the product.

M. Madinier endorses the statement of M. Hardy, that the juice of the sorgho contains naturally a fermentative principle, sufficient for perfect alcoholization, but thinks it best to throw in with the juice a few of the fresh crushed canes, which greatly accelerates the attenuation. He also advises very wide and shallow fermenting cisterns, so as to expose as much surface to the air as possible, and to set the cisterns at a temperature of twenty or twenty-five degrees centigrade, equal to seventy-seven Fahrenheit. M. Sicard, in his work, merely collates the experiences of others, among which are Beauregard, Fissiaux, and Raoul. One point, however, they all agree upon, that is, that the wash ought to be kept in a room, the temperature of which is eighteen degrees centigrade, or say sixty-four Fahrenheit.

M. F. Bourdais, however, a distiller in Algeria, at length, in 1856, treats the matter in a thoroughly practical and scientific manner; he gives us facts, not theories, and proves most conclusively that the sorgho is perhaps the best alcohol-producing plant yet discovered.

The operations on which he based his calculations and deductions were all on a large scale, and therefore less liable to error than the laboratory experiments of most of his predecessors in this field. He planted five hectares, say ten acres, with sorgho, and professes to give results with scrupulous exactitude.

COST TO PRODUCE A GALLON ALCOHOL FROM SORGHO, NINETY-FOUR
PER CENT. STRENGTH.

He found that to cultivate and prepare for grinding one hectare, or say two acres, of sorgho cost him 685 francs, or say - - \$137 00

But of the green fodder stripped from the canes he sold seventy-eight quintals, or say 17,000 lbs., at three francs for 100 kilogrammes, which is sixty cents per 220 lbs., - - 46 80

\$90 20

Of prepared canes he obtained ready for the mill, 520 quintals, or 114,920 lbs., making cost of production per quintal of 220 lbs., about $17\frac{3}{4}$ cents.

Each quintal (220 lbs.) yielded, on distillation, 5 litres 20 centolitres, or say $1\frac{1}{4}$ gallons, alcohol, at 94°, thus costing per litre of $1\frac{3}{4}$ pints 0 15 1, or about - - - - - 4 cents

To which add cost of crushing, maceration, fermentation, yeast, distillation, and rectification, 10 cents

Cartage to town, - - - - - 1 $\frac{1}{2}$ cents

Cost per litre ($1\frac{3}{4}$ pints) of alcohol, 94°, 15 $\frac{1}{2}$ cents
or say 71 cents per gallon, nearly.

DETAILS OF THE MANUFACTURE OF ALCOHOL FROM SAY FIVE HECTARES,
OR TEN ACRES, OF SORGHO, AS GIVEN BY BOURDAIS.

The canes, stripped of their leaves, are passed through a cane mill, the juice runs into a tank capable of holding

forty hectolitres (eight hundred and eighty gallons), the bagasse, or crushed canes, still retaining a considerable quantity of juice, are steeped in hot water. Nine hundred and fifty kilogrammes (two thousand six hundred lbs.) of these yield twenty hectolitres (four hundred and forty gallons) of juice and water at 3° Beaumé, while the juice first expressed stands 10° Beaumé.

On finding it was going to cost him too much to cut and gather the grain from his sorgho, he determined not to do so, but after choosing sufficient of the best seed for next year, he left the grain attached to the stalks, and crushed all together.

When he came to macerate with hot water, the heat immediately acted upon the starch of the corn, and determined its transformation to sugar. He thus obtained, by the same operation, both the saccharine of the grain and the residue of the juice from the canes.

The juice, on leaving the steeping vats at 3° B., must be enriched with pure juice till it marks 5° B. Eight hectolitres of this (one hundred and seventy-six gallons), at a temperature of 30° centigrade (86° F.) are mixed in a fermenting vat with five litres (one and one eighth gallons) brewers' yeast; this he calls the *foot*. In an hour it is in a high state of fermentation, and he then fills up the vat with twenty-two hectolitres (four hundred and eighty-four gallons) also at 30° cent. (86° F.); in another hour the whole is fermenting. He states the above from his own experience, and remarks that the fermentation proceeds regularly, requires no attention, is never too rapid, and always falls to zero on the areometer in twenty, or at most twenty-four hours. It is then ready for distillation,

and will yield eight litres (one and three fourths gallons) alcohol for each hundred litres (twenty-two gallons) juice at 10° B.

From these statements it would appear that, however little success may attend the attempt to produce crystallized sugar from the sorgho, that there need be no difficulty, at all events, in making good domestic rum, alcohol, and other kindred products from its juice. The following instructions for setting a vat are not, however, to be taken as based upon the result of my own experience, for as yet I have only been enabled to experiment upon a small quantity of syrup, which was over a year old, badly defecated and burned, and withal considerably acid. I have nevertheless carefully perused the reports of the French operators, and extracted what I considered best from each, which was applicable to our climate and national habits.

TO SET A VAT.

If the farmer be manufacturing syrup from his cane, let him select the most perfectly ripened and healthy canes for this purpose, setting aside those which have only partially ripened, or have been frosted, for the manufacture of rum or alcohol; by this means, and saving all the scum of the pans for the same purpose, he may thus be enabled to use all his product to advantage, and waste nothing.

Supposing him to have determined on making rum or alcohol only, let him cut his canes, grind them, and put his juice into a pan to evaporate slightly. If the juice

marks 8° B. no evaporation need take place, but the pan be used to raise the temperature of the liquid to say 80° Fahrenheit, then discharge the contents of the pan or pans into a vat suited to the quantity the farmer desires to ferment, fill this vat to within a foot or nine inches of the top, and, if you can get it, add by measure one gallon of brewers' yeast to every hundred gallons in the vat, first take four or five gallons of the warm juice, mix the yeast well up in it, and return it to the vat, agitating the whole well together. In a couple of hours or so, if the weather be propitious, the contents of the vat will seem alive or boiling, owing to the bubbles of gas which are rising to the surface, and an aromatic flavor will begin to arise. The vat is *now* fermenting. The door of the room or shed where the vat or vats are placed, must be kept shut or open, as the case may be, so as to keep the temperature of the air about 65° or 70°. In winter a stove will be necessary, for if the juice should get chilled, in all probability it would stop fermentation, and give trouble. Examine the vat from time to time, to see that all is going on well; in twenty-four hours after the fermentation has begun, take out sufficient to float Beaumé's saccharometer, and insert a thermometer in the vat. You will find, in all probability, that the wash has become *attenuated* to a certain degree, and has risen in temperature to 80° or 82°. That which yesterday marked 8° B. now perhaps marks only 5° or 4° B., in which case you may be sure your vat is progressing as it ought to do. Had you set your wash with common molasses, instead of sorgho, it would not have attenuated one degree in so short a time, and the fermentation would

only be commenced. This is a peculiarity in the sorgho greatly to its advantage in making alcohol.

Attenuation is the term applied to that action in saccharine fluid mixtures by which they gradually lose part of their gravity in fermentation, and it attains perfection, if the wash can be brought to the same specific gravity, or less, than water itself. Before fermentation, the mixture being much heavier than water, is shown by the areometer. This change in density is owing to the sugar, which is denser than water, changing into alcohol, which is lighter; and as a mixture of alcohol with water must, from the difference of gravity between the alcohol and the water, render a given bulk of such mixture lighter than the same bulk of pure water, it follows that as the sugar in the wash changes into alcohol, the mass changes its gravity, or *attenuates*.

In forty-eight hours, in warm weather, after the wash commences to ferment, examine it by pushing the head or scum on one side, if it has not already sunk to the bottom, and if you find that the bubbles cease to rise, and that the temperature has gone down to 70° or 75°, get your still ready and distil the spirit as soon as possible. If you leave it twelve hours after this, the vat will have commenced the acetic fermentation, and be in process of making vinegar at the expense of your alcohol.

Since commencing this article on alcohol, I have been enabled to test, to my own satisfaction, the capability of sorgho syrup, even in an advanced state of acidity, for making spirit. The quantity experimented upon being small was against the success of the operation, especially in the fermentation. Yet, nevertheless, I obtained a

very strong, well-flavored spirit, infinitely superior to whiskey, and giving evidence that, had the syrup been fresh, a sorgho brandy would have been made, which would have compared favorably with any of the French brandies in quality. I am not aware that sorgho spirit has been previously made in America; it may, therefore, prove interesting to give the details of my experiment.

On Tuesday, the 17th of August, I secured from Mr. H. S. Olcott a little over a quart of sorgho syrup, part of a small quantity sent to him by Mr. Peters, of Georgia, the product of last year's experiment; it was extremely acid, having been imperfectly defecated and clarified, burned in the boiling, and contained much extraneous matter; its color was a dirty yellowish-brown, and its density, by Beaumé's saccharometer, was 35°.

I commenced operations upon it at 2 P. M., on the 18th, by mixing in a pail five quarts of water, heated to 100° Fahrenheit, with one quart of the syrup; when the mixture was effected, the temperature of the whole stood 90°. I set the temperature thus high, owing to the smallness of the quantity, being doubtful as to the fermentation proceeding fast enough. I also made the density, which was 9°, one or two degrees higher than would be necessary in larger quantities. Having stirred the whole thoroughly, I took out a small portion in a tumbler, into which I put one quarter of a pint of fresh brewer's yeast; this I beat up with a spoon, and when well mixed I poured it into the pail with the rest, and stirred the whole together. The temperature of the room being 75°, I left it undisturbed for a time. On examining it two hours

subsequently, I found that a lively fermentation had set in, and that the temperature had fallen to 77°; at ten P.M. it was in a high state of fermentation, the temperature had risen 2°, and the wash had attenuated 1½° Beaumé. In twenty-four hours from the time of starting, the temperature was 80° F., and the density 4° B. In forty-two hours the temperature was 2° lower, the density 2° B., and the fermentation less lively. In forty-eight hours the temperature had fallen to 76° F. Fermentation had almost ceased, and the wash marked only ½° Beaumé, which was a very good attenuation under the circumstances.

I now distilled the whole in a small copper still, a model of Figure 3 of the distillery cuts. The *foreshot*, or first runnings, I set aside; as also the *faints*, or last runnings, the balance—about 1½ pints—was a pleasant aromatic spirit, resembling brandy, containing 55 per cent. alcohol.

This distillation having been made in nearly a simple still, over the naked fire, was the severest test the sorgho syrup could be put to; for had there been any disagreeable peculiarities inherent in it, they would have appeared in the spirit run in this way. As was to be expected by so imperfect a process of distillation as the simple still and worm affords, a good deal of essential oil came over with the spirit, as well as water. So I determined to redistil the 1½ pints at a low heat, in order to see what improvements could be effected. The small still I used being intended for experiment, was so arranged as to interpose, when required, a stratum of water between the fire and the substance under distillation, which, by

this means, was preserved during the operation at a temperature not exceeding 212° .

Having filled the bath of the still with water, and urged the boiling, the spirit soon came over; as before, I rejected the foreshot and foints, in this case returning the foreshot to the still; the result was about $\frac{2}{3}$ of a pint of pure, well flavored spirit, of $72\frac{1}{4}^{\circ}$ strength.

Such results are encouraging and full of promise for the future; for it must be remembered the stock in this case was imperfectly cured to begin with; had been kept in a demijohn over a year fermenting, and had thus lost part of its alcohol before it came into my hands. Yet, nevertheless, I will venture to say, that the spirit produced from Mr. Peters' first experiment in sorgho syrup, will rank favorably with many samples of spirit in the market.

Having got so far, the only question that remains, is the important one of apparatus. Of course, the size must be proportionate to the quantity of brandy, low wines or alcohol, the planter intends to manufacture; but, as many circumstances have got to be considered in arranging a distillery, besides the mere size of the still, I would recommend that the planter, before taking steps in the matter, state his case to some competent person and obtain his advice.

To farmers and others, who do not intend to make a regular business of distilling, except at times when no other occupation occurs, as in winter, I would recommend to defecate and clarify their juice as directed in the chapter on syrup and sugar, using, say two pans, when the juice is well cleaned. Then boil down to 35°

or 36° B., allow to cool, and barrel it up for winter distillation; the juice treated in this way will keep for years, if well defecated and kept in a cool place. The form of still they ought to use, should be the simple still and worm, either with or without a wash heater. The following cuts represent the common still; Figure 1 in elevation, Figure 2 in section:

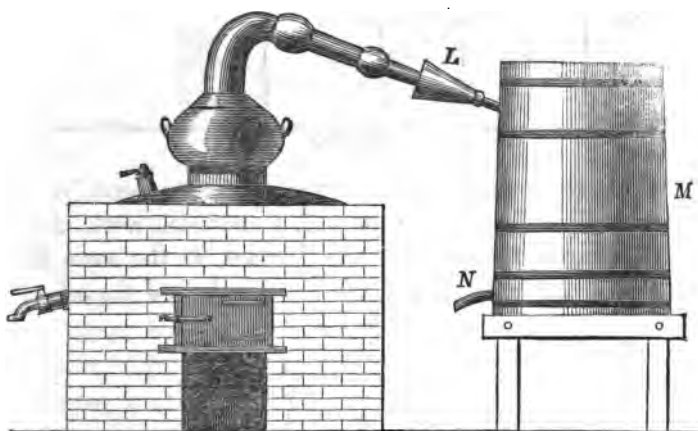

Fig. 1

In the above cut, the brick work, body and goose neck of the still are shown. L, is the offshot of the worm; M, the worm tub, full of cold water; it should have a stream of water supplied to it, to prevent its getting too hot; N, is the drip pipe of the worm. A section of this form of still is shown in the following page, at Figure 2, of which A is the body of the still, B the cap or capital,

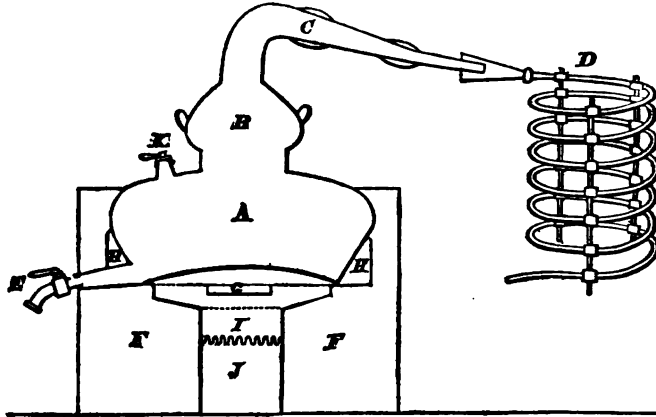

Fig. 2

C the goose neck, leading to the condenser worm D. E is the discharge cock of the still, F the brick work, G the opening of the flue into the furnace, H the same flue going round the still, I the furnace bars, J the ash pit,

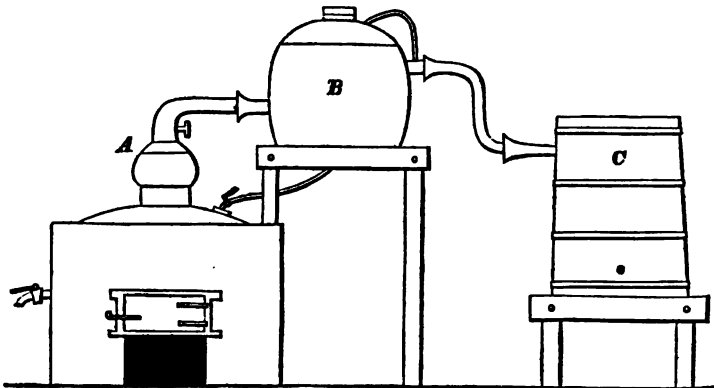
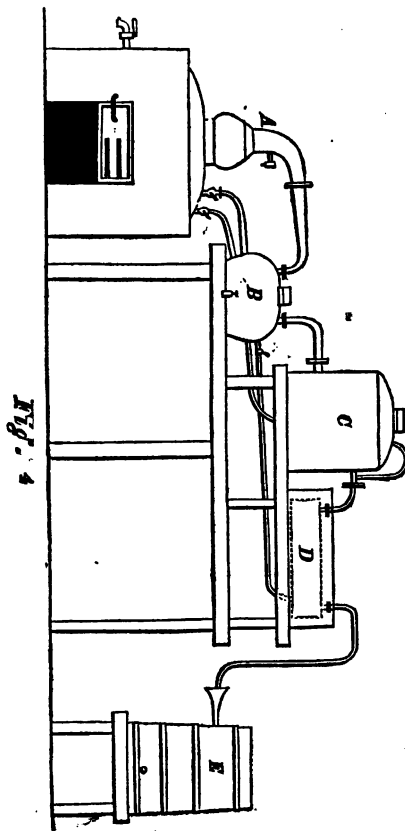

Fig. 3.

and K the charging screw, where the still is filled. This still makes low wines.

By adding a wash heater to the above, a great saving in time and fuel is effected, besides, a purer and stronger spirit is obtained. This still is shown at Fig. 3, page 158, of which A is the still, B the heater of the wash for the



next charge, and C the worm. To operate with this still, fill the still through the heater, and then fill the heater. When the charge in the still is run over, draw off the spent wash, and fill up again from the heater.

When a pure spirit, standing 80° to 90° , is wanted, a still like Fig. 4, on page 159, is required; of which A is the still, B the doubler, C the heater, D the check cylinder, E the worm.

Alcohol 95° may be obtained by a distillery similar to

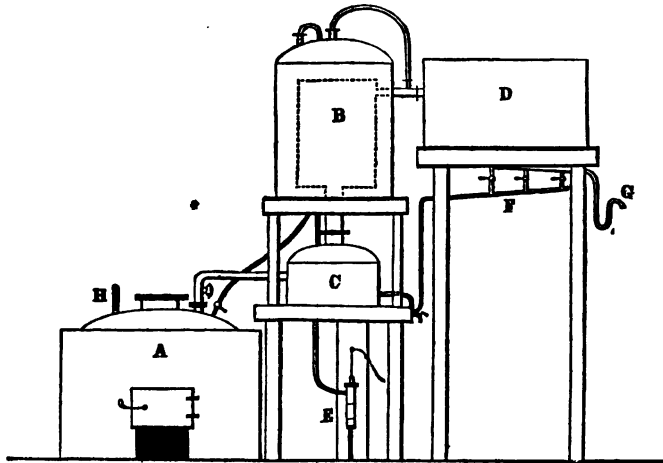
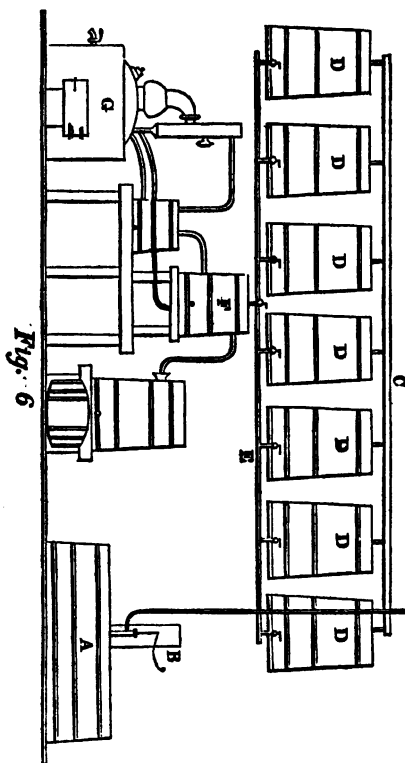

Fig. 5

In this A is the still, B the heater, with a peculiar arrangement inside, C the doubler, D the separator, E the pump to feed the heater with wash, F the separator pipes, G the drip pipe, H a thermometer to tell temperature of wash.

Where the quantity of sorgho planted is large, a very

good rum or low wine still is shown at Fig. 6, together with the general arrangement of the still house.



A is the mixing tub, B the pump to raise the wash to the gutter C, which supplies the fermenting vats D. E is the pipe leading from the vats to the heater shown at F, G is the still. This still may be so arranged as to run very strong spirit.

By means of stills without columns or separators, low wines only are made with advantage. These are named in contradiction to high wines above 65°.

The stills hitherto represented have been of the intermittent kind, but in the cut on the opposite page a continuous brandy or alcohol distillery is shown. These stills have a continuous stream of spent wash running out at the bottom, while a corresponding stream of live wash runs in at the top. They are rather expensive, and require some practice to operate.

The apparatus represented in the cut is on the principle of Durosne & Cail, of France, who got it up some years ago for the purpose of distilling brandy from wine. It is extensively used in France, and there are a few in use in the United States. I refrain from any description of this still, as it would be too tedious, and perhaps, after all, prove incomprehensible in mere words. Suffice it to say that it yields a pure spirit, and of any required proof under 95°.

To planters and farmers, many of whom will doubtless this year order distilleries and other apparatus for their various operations on sugar, I would advise that they stipulate beforehand with the manufacturer, for a full written description of the proper mode of erecting and working each apparatus, otherwise there will be trouble and expense before it is finished.

One half of the failures in apparatus on sugar estates, are owing in the first place, to the mechanic who undertakes to make a machine or a distillery, while, in the meantime, he is ignorant of the first principles of the purpose to which such still or machine is to be applied; and

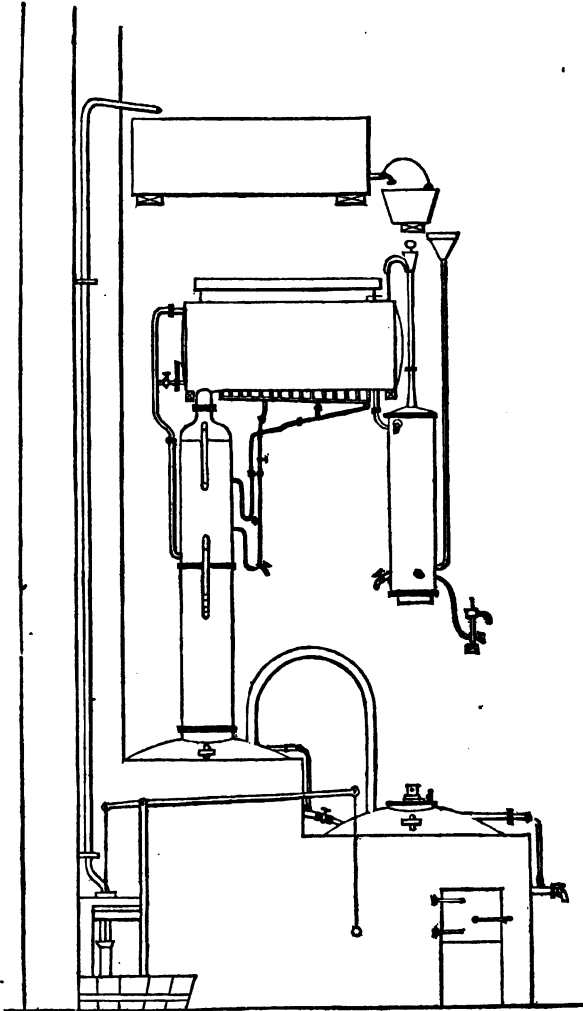

Fig. 7

in the second place, it is due to the person giving the order, who, probably, is little able or willing to enlighten him: in either case dissatisfaction and loss is the result.

In the manufacture of alcohols from the sorgho for the market, it is well for the farmer to know what is required, as regards strength and quality, so as to be guided in making an article which will find ready sale; and first and foremost, doubtless, he would like to know what is considered the *market proof* of spirits in America. By *proof* is meant the strength in alcohol which a liquor indicates on the areometer, and is derived from the English excisemen, who *proved* each cask as it came from the distiller or importer, levying a heavy duty per gallon on the amount of alcohol contained; when it passed the officer's hands, he gave a certificate of its strength, which was *proof* to the customer, the bung being sealed up and stamped.

In America usage has designated a certain per centage of alcohol in liquors, as the standard strength on which the price is to be calculated, and according as the percentages exceed or fall short of this, the spirit is *above* or *below proof*. This standard is composed of one half water and one half spirit, marking 50° on the guage or areometer, at the temperature of 60° Fahrenheit.

Of course, if the farmer be far from his market, the less water he transport in his casks the better, and he ought in this case to make high wines or alcohol, now so much used for camphene, &c., whilst the one who is under less charges for transportation, may be guided by the demand, whether it shall be low wines, high wines, alcohol, brandy, or rum that he produces from his juice—all

these various liquors being merely the result of a little difference in the mode of fermentation and distillation.

Before taking leave of the subject, I would state that the sample of Mr. Peters' syrup, referred to before, on being offered in the market as rum, was appraised at 90 cents to \$1 a gallon, Porto Rico rum being worth \$1 10. In the shape of brandy, \$1 to \$1 50 was offered, while in the shape of 95° alcohol, 65 cents was the price.

Now, the farmer, so soon as he knows what it costs him to make a gallon of syrup, can tell at once what these prices indicate in the shape of profit, by adding eight cents per gallon, which is an over estimate of the cost of conversion into spirit. Supposing him to obtain only 200 gallons, whereas he ought to get 400 gallons syrup per acre, and it costs him fifteen cents per gallon to make it, his brandy would stand him in twenty-three cents, and be a purer and more wholesome article than most of the trash palmed off upon us as French cognac.

Say, 200 gallons syrup, per acre, 15 c.,	\$30 00
Cost to ferment and distil, 8 c.,	16 00
	<hr/>
	\$46 00
Returns—200 gallons proof brandy, at \$1,	200 00
	<hr/>
Profit per acre,	\$154 00
Besides fodder and seed, worth, say,	50 00
	<hr/>
Net profit,	\$204 00

On reading over the foregoing, I see that I have omitted mention of the means by which, in the absence of yeast, fermentation may be induced in the wash, or preserved

from year to year, as also the use to which the spent wash may be applied where water is scarce, or at a distance.

As a general thing, well water, if good, is better than river water for mixing with syrup, or other substances to be fermented, inasmuch as it holds in solution less vegetable matter. Spring water, which has lime in solution, is very good, provided it does not contain other minerals unsuitable for the purpose. Trial in every case can alone settle this authoritatively.

If the reports of the French chemists apply to the sorgho of this country, there need be no anxiety as to the success of its fermentation, possessing, as it does, a strong tendency towards alcohol even unaided. In all cases, however, I would add to the vat, as directed, one quarter per cent. of fresh crushed canes as a ferment. This, as in the case of grape stalks on wine, secures the result. If a brewery be near, by all means get fresh yeast from that.

After one vat or cask has been put into fermentation, it will be easy to inoculate all the others from it, for on the bottom will be found, on drawing off, a grayish substance, which will induce fermentation wherever it is applied to saccharine solutions.

By many, the best flavors of the West India rums are attributed to the mixture with the wash of a certain amount of spent wash of previous distillations; this is done generally in the proportion of one third or fourth; and in case this plan be found favorable to the sorgho, I will give a few simple directions on this head, which may be varied as experience dictates, when sorgho distillation has become an *institution* among us.

The scum of the sugar train, during crop, is used to mix in the vats, six gallons of scum being considered equal to one gallon of syrup or molasses. Twelve or fifteen per cent. of saccharine matters, whether of scum or syrup, is a common mixture, as, for instance, eighteen gallons scum, ten gallons syrup, thirty-six gallons spent wash, and thirty-nine gallons water, will do very well; say thirteen per cent. of saccharine, or twelve gallons syrup, may be used, so as to make fifteen per cent. saccharine.

When the planter has got through with his distillation for the year, he leaves his vats full of spent wash, in order to prevent their leaking, as well also as to preserve the fermenting principle which the wash acquires before next season. After standing a short time, the wash throws to the surface a thick crust or scum, which protects it from the air, leaving the fluid underneath clear as sherry wine. This method I would advise our farmers or planters to adopt with their vats for sorgho, or wash them well with lime, and fill with pure water, which, if followed with the other suggestions I have given, will no doubt place us in a better position as regards alcohols than any other country in the world, inasmuch as, for the production of alcohol at all events, the sorgho will become sufficiently ripe throughout the Union, from Maine to Texas, and thus give us unrivaled facilities, not only for supplying our own markets, but those of the world, with this useful solvent.

For the preceding remarks on alcohol, I am indebted to the same gentleman who furnished the illustrations and descriptions of sugar-making. He, as well as my-

self, takes great interest in the development of our new plant, which, both as fodder, cereal, saccharine, spirit, beer, and wine, seems destined to add so largely to our wealth as a nation.

DESCRIPTION OF GROUND PLAN.

See p. 112.

In the cut representing the plan of a sugar house, A represents the steam boilers outside of the building ; B the cane shed, built of brick or stone, with wide archways ; C, the mill-house, having two floors, the mill on second floor ; D, the boiling-houses, with two trains, and a small office which overlooks both the mill and boiling houses ; E, the cooling house ; and F the purgery. These two latter are in a separate building connected by a railroad, both to avoid risk of fire and admit of being kept locked up to prevent pilfering. G is the distillery, about one hundred yards removed from the other buildings.

a shows the cane carrier ; *b* the mill and engine on the second floor, supported on solid masonry ; *c* a shute which takes the place of the bagasse carrier, and delivers the crushed canes into a mule cart underneath, outside ; *d* are juice tanks, to receive juice from mill ; *e* are oblong defecators attached to the trains ; *f* are the trains of pans ; *g* railroads to carry the syrup to the coolers, and the sugar from coolers to purgery ; *h* are the coolers ; *i* are the alley ways, level with furnace mouths ; *k*, furnace mouths ; *l*, sugar hogsheads in purgery.

CHAPTER VIII.

VINEGAR.

Like all other saccharine juices, the sap of the sorgho, raw, and the wines and cider made from it, will rapidly pass into the acetous fermentation. As soon as the cut end of the stalk is exposed to the atmosphere, the oxygen attacks it, and the fermentation commences. I have found the sap of stalks which had lain in stack on our place for two months, to be as acid as the best vinegar, and although I have had no personal experience in vinegar manufacture, I still should not be afraid to testify, with no other facts corroborative, that the sorgho is a vinegar-producing plant.

The Count Moigneric, says Dr. Turrel in the Imperial Society's Bulletin, of September, 1856, made vinegar by watering the bagasse, already crushed, with fresh juice of the sorgho. He obtained the acetous fermentation and a perfect vinegar.

Mr. D. Jay Browne, in his remarks before the United States Agricultural Society, said that he believed fifteen hundred gallons of vinegar could be made per acre from the sorgho. He had a specimen at his house in Washington, and pronounced it very good.

Lacoste says likewise at page forty-four of his book, "that the juice of the sugar sorgho submitted to the acetous fermentation, will produce vinegar of excellent quality; and it will also be profitable to submit to this

transformation the weaker alcohols arising from the final distillations."

The methods for the production of vinegar are so simple, as to be familiar with almost every one of my readers, and it will, consequently, be useless to occupy much space in detailing them at length. I would simply recommend that the practice usually employed in treating the juice of apples, of the sugar maple, and the various other saccharine fluids commonly employed for the manufacture of vinegar, be applied to the juices of the sorgho and imphee as they come from the mill.

Sicard says that he has been in the custom of making vinegar of the knots of the cane stalks, and of adding to them such canes as were more or less spoiled. His process is extremely simple, and is as follows:

"Bruise the pieces in the mill, put them in contact with a sufficient quantity of water to cover them a few inches, let them ferment then all alone until the liquid has acquired the qualities desired for good vinegar. It is indispensable to draw this vinegar off once or twice, with a view to removing from it all foreign substances." He says that his vinegar is of a yellowish white color, and of a very agreeable acidity. He has sometimes allowed the knots to ferment before covering them with water, and in this way has obtained a vinegar very deeply colored. For the purpose of making vinegar, he has likewise made use of the cider or *piquette* of the sorgho, by adding to it a slight quantity of tartaric acid. He says vinegar can likewise be obtained by putting into a barrel the residue of canes from which the juice has been extracted for the manufacture either of sugar or alcohol. In this case he

left them without disturbance until they had acquired a heat, of which he was made sensible by putting the hand in the mess ; he then added to it water, and let it ferment as before mentioned.

STARCH OF THE SEED.

The consumption of starch in the United States, at all times large, has recently increased, owing to causes, among which may be enumerated the present universally prevalent custom of our females wearing stiff skirts ; and much more starch is eaten than formerly, prepared in various forms for the table, such as starch, farina, tapioca, &c. The seed, deprived of its envelope, has been submitted to numerous experiments by Mr. Wray, Count Beauregard, Dr. Sicard and others, chemists and amateurs, and has been found to yield forty-five per cent. of pure starch of very excellent quality. In fact, it only needs for a person to cut in two a fully matured seed, to be convinced of the possibility of causing starch manufacturers to be considerably interested in this plant, when the area under cultivation shall be such as to bring down the prices of the seed to a moderate rate. On taking off the outside envelope of the seed, the one in which is contained a very deep purple dye tint, we see adhering to the starchy matter, another of a clear brown color, and somewhat unctuous to the touch. So intimately is it a part of the composition of the seed proper, that we anticipate an impossibility to separate it, except by the process applied to barley, which is known as *pearling*, and in this way the desired result will be easily attained. What will be a

cheap and expeditious method for removing the seed hulls, we cannot at present say. If it can be shown that the hulls, are valuable for the dyes which they will yield, ingenuity at once will be stimulated to produce a hulling machine; and if, as we think very probable, it shall be found the starch of the seed can be readily made use of, then again the same causes in operation will demand such a machine. But, at present, Dr. Sicard has made his experiments, as I have made my own with the hulls, by rubbing the seeds together in such a manner as to cause the hulls to separate of their own accord. Dr. Sicard made an experiment with about 175 lbs. of the seed to determine the proportions of coarse bran, middlings, and fine flour, and obtained thirty-three pounds of each of the two former, and about ninety-five pounds of the latter. The coarse bran and middlings were both of a violet tint, arising from the coloring matter impregnating the outer lining of the hull. The fine flour itself offered to the eye an appearance of violet slightly bordering upon a rose color, and even after having been passed through a silken sieve, was still of a very pale rose color. To assure himself that the coloring matter which thus tinted the fine flour was merely contained in the outside covering of the seed, he undertook very minute experiments, completely removing all the hull and the two successive interior coatings before passing the seed through the mill, and even made use of chemical agents to remove the color. The result, it is true, was the production of a starch of very brilliant whiteness, but his experiments proved to my mind that the production of pure white starch will be a matter of considerable difficulty. It will have a pale

rose color, which may, or may not, militate against its general introduction. He made from the starch at different times bread and cakes, and in the different cases varied success, some being palatable and others not. The flour of the sorgho is of an inferior quality as compared with wheat flour, and others of the finer grains, and any mixture of that with wheat flour is a fraud upon the stomach, giving a quantity of inferior aliment with an accompanying bribe of a better one, as quack physicians will make palatable to their patients nauseous pills by surrounding them with a coating of sugar. In speaking, however, of starch and the various forms of food to be made from the Chinese Sugar Cane, I would not be understood as embracing in the same category those which the imphee may furnish, for, because of the absence of any coloring matter from its hull, the peculiar plumpness of the seed, and the large quantity of starch found to be present, I have reason to believe that it will indeed be a valuable acquisition, and its culture be duly undertaken with this simple object in view. Be that as it may, we cannot alter the *composition* of the starch, nor of the other components of the sugar. Whither tinted rose color, or as white as the driven snow, it still will have its own unchanging proportions of carbon, oxygen, and hydrogen, which will represent a certain nutritive value, and for animals it cannot but prove, as indeed experience has already proved it to be, a very excellent fodder crop.

Madinier says, at page 10, that the seed contains 10 to 12 per cent. of nitrogenous matter—gluten—and about 60 per cent. of starch, which would make it, so far as the proportions of nitrogen are concerned, to resemble our

common corn; but where he obtained his analysis, I am not informed. He says that the real use of the sorgho is not for bread-making, but it should be eaten on the farm in the form of broth and soups for the laborer, or to be boiled up in quantities and given for fattening pigs and cattle.

DYE STUFFS.

Previous to the receipt of the pamphlets from Messrs. Hedges, Free, & Co., which were sent to them by his Excellency our Minister at Paris, I had seen in my researches after the facts collated by French experimenters and published in the French journals, occasional mention of the experiments of Dr. Sicard of Marseilles, in procuring from the hulls of the seed a tint for dyeing; but not the slightest clue was given as to how the dye was produced. Thinking it an interesting aspect of the sorgho culture, I was anxious to duplicate, if possible, his success; and to this end made various laboratory experiments with alcohol, sulphuric ether, the various acids, boiling the hulls in a retort with oxalic acid, muriate of tin, alum, dilute acids, and plain water, and obtained a number of tints of greater or less brilliancy. Of these one was a deep purple, obtained by simply boiling the hulls in pure water for about fifteen minutes; another, a beautiful rose colored fluid, was made by boiling the hulls of another sample (received from France) in very dilute sulphuric acid, a few drops of the acid to a pint of water being sufficient. And, by dropping into the pure water in which the hulls were being boiled

a few drops of nitric, muriatic, or acetic acids, as the case might be, I obtained different shades of red. I inserted in the liquid strips of cotton and silk fabrics, and set them with alum. In one case, I took a piece of white ribbon, and by boiling it in the tinted solution for a few moments, obtained a very deep color. In another case, in a weaker solution, a ribbon was colored pink. Being entirely unacquainted with the principles of dyeing, of course my experiments were but imperfect, and were useful only as proving the fact, that in the hulls was actually contained a tint, which might be very easily separated. They led me to believe that, under proper circumstances, this dye could be extracted and made into pigments with profit.

In Dr. Sicard's "Monograph of the Chinese Sugar Cane," he has introduced a specimen of twenty-one colors obtained by him from the seed, and for which he has received letters patent. They range through all tints, from a light buff to a very deep purple, but do not, of course, present the brilliancy which they do when reproduced on different fabrics. "In fact," as he says himself in his Postscript, "it would be difficult, by these specimens, to give the slightest idea of the beauty of the tints which may be obtained on silk, woollen, or cotton stuff. The first substance has especially a very great affinity for the coloring matters obtained from the plant which has occupied our attention; but if silk has more affinity for all the colors in general, there are others which show remarkable beauty on woollen and cotton stuffs. The coloring principles which we have obtained are to the number of nine, entirely independent from

each other, and capable of giving colored salts perfectly crystallized. By combining our coloring principles with different chemical substances, there are obtained not only a number of known colors, but, furthermore, tints on the stuffs which are unknown in France, and like which we have no specimens except the beautiful embroideries which we receive from China. We sincerely hope that the Government, comprehending all the importance of these discoveries, shall publish the results obtained. It is impossible that a plant which, in the hands of a single individual, has given results so extraordinary and so varied, should not be called to play a great part in all branches of industry."

I translate as follows the account of his curious researches: "The hulls which envelope the seeds of the sorgho are tinted with a reddish brown so deeply that they appear black. The tint is due to a complex coloring matter condensed in this part of the seed, but which also exists in the radicular fibers at their origin, and in the young suckers. This coloring matter is insoluble in cold water. Boiling water dissolves it, with a red violet color. Alcohol, even cold, takes it from the hulls, and becomes colored with a deep red. Ether dissolves it, and takes on a bright red tint. A boiling solution of alum takes on a reddish lilac color. Concentrated sulphuric acid dissolves it with a deep reddish color; chlorohydric acid with a reddish orange color; the alkalies with a brown.

"The acid solutions in water, caused to precipitate a substance of a deep reddish brown tint. Alkaline solutions precipitated by acids brown flakes, which redden

upon repeated washings. The supernatant fluids are yellow. The alcoholic tincture evaporated, gives crystalline scales, which seem black when viewed in a mass, and that a fatty substance renders brilliant; the liquor and the waters from the washings are of a yellow color.

"Tincture of ether gives, likewise, by evaporation and an addition of water, a red precipitate, upon which floats a yellow liquor.

"There are, then, in the hulls of the sorgho, two coloring principles; the one red, slightly soluble in water, and soluble in alcohol, ether, the acids, and alkalies; the other, yellow, very soluble in water, and in the other solvents, which is not precipitable from its solutions like the red matter.

"The red matter, which we may call *purpurholcine*, presents itself under the form of a reddish violet powder, so deep in color that it appears black; it has no smell; its taste (very weak) is a little bitter and astringent. Heated in a closed tube it does not volatilize, but gives empyreumatic vapors, which condense themselves into yellow oily drops. In presence of potashed lime it gives, under the influence of heat, alkaline vapors. It is then an azotized substance, and of which we will, further on, determine the atomic composition. The *purpurholcine* is but little soluble in water, but dissolves readily in boiling water, in alcohol, cold and warm, and in ether, with a reddish color; sulphuric acid and chlorohydric acid dissolve it with an orange color. Potash, ammonia, lime water, and the water of baryta, communicate to it an intense color; alum, a red violet. It is not soluble in fixed oils; it can be prepared by several pro-

cesses. First, treat the seeds with concentrated sulphuric acid; allow them to remain in contact with it one or two days; then it is mixed in a large quantity of water; the whole is thrown upon a filter and washed until the liquor is no longer acid; the carbon which remains upon the filter, mixed with the coloring matter, is treated by warm alcohol, and gives a tint, which it is only necessary to distill, and add to it water, to obtain the purpurholcine, in brilliant scales, tinged with a little fatty matter. The liquid retains the yellow substances, and a little of the purpurholcine.

“Second: The seeds can be treated directly by alcohol and operated with, as above given for the alcoholic tincture; ether conduces to the same effect.

“Third: We can furthermore employ a solution of potash; it makes a brown magma, which is to be filtered; and in the liquor put with care some chlorohydric acid; brown flakes are precipitated, upon which will float a yellow liquid. These are to be separated, washed well, redissolved in alcohol, and the latter gives, by evaporation, the purpurholcine.

“Uses: This coloring matter can be used for dyeing. By varying the dissolvents and the mordants, are obtained, upon cotton, woolen, and especially upon silk stuffs, beautiful tints, which vary as much as can be desired in the browns, the grays, the reds, the oranges, and lilacs. Our conviction, in this respect, is based upon dyeing experiments, on a small scale.

“The yellow matter, which we shall call *xantholcine*, is very soluble in water, either cold or warm. Soluble in acids, which cause it to become an orange yellow; the

alkalies preserve its colors. It forms with different metallic oxides, red and orange lakes.

"The stuffs, with the use of mordants, take on various tints of yellow and of orange, brown, and rose color. It is obtained at the same time as the red matter, and remains in solution in the different liquids where the purpurholcine is precipitated; but it is not pure, and is mixed with the red matter. The best process to isolate it, is to make use of potash. It can be purified, by making use of the process indicated by Kullmann, for the yellow matter of the madder which this chemist has named Xanthine. Thus the seeds of the sorgho contain two coloring matters, which applied to dyeing, can replace madder and give all the shades which are obtained from the roots of this plant. The purpurholcine differs from the red matters of the madder by its non-volatility. The Xantholcine seems identical with the Xanthine."

Dr. Sicard's process having been made public, has created considerable interest in the city of Lyons among the large silk manufacturers, and experiments are being made to test the value of his coloring matters, the result of which will settle the question as to its practical utility.

CEROSIE; OR, THE VEGETABLE WAX ON THE STALKS OF THE
SORGHO.

In a previous place, I mentioned that as the plant approaches maturity, a white efflorescence makes its appearance upon the outside of the stalks, accumulating,

in the greatest proportion, under the footstalks of the leaves. This vegetable wax—cerosie, the French call it—is similar in its composition to the wax produced by bees; it is, however, dry, hard, and may be pulverized; fusible at 90°, and if mixed with purified tallow, and made into candles, burns with a clear brilliant light. It is employed for this purpose by the inhabitants of the north of China. Mr. Hardy, the Director of the Government Nursery in Algiers, makes a calculation as to its value per acre, by which he shows a net profit of thirty-six dollars, to be added to the other profits given by the cultivation of the sorgho; but I do not see how we can, for a moment, adopt these views as applicable to our conditions of climate and prices of labor. In Algiers, Mr. Hardy could secure the service of Arab boys and women at a very low price; and in China, the labor of a man is remunerated with only a few cents per day; but in our country, we cannot hire a laborer for less than a dollar a day. It seems to me that, taking into consideration the fact that the cerosie is not secreted by the stalks so abundantly as it is in Algiers, we cannot spare the laborers from more important duties, to go over the field and carefully scrape the wax from the outside of the stalks. To obtain a small quantity, to illustrate my lectures before the Legislatures last winter, I employed one of our pupils, for nearly half a day, and the little success that he met with, convinced me at the time, that any calculations of its becoming an important commercial commodity in our own country, were futile, unless, perhaps, by either steaming the stalks in a vat after they were cut, or by the use of some machinery, the wax

could be removed more expeditiously, and in greater quantity than it was in this instance.

Any one of my readers can satisfy himself that it is indeed a wax, and burns exactly like wax candles, by collecting a small quantity of it into a heap and setting fire to it with a match. The flame is very white and beautiful, so long as it lasts.

Professor Gray, at page 60, section 86 of his "Botanical Text-Book," supposes from the fact that bees produce wax from sugar, and that the wax of the sugar cane sometimes passes into sugar, that the vegetable wax found in plants is formed of sugar, or similar products. The *Ceroxylum Andicola*, or Wax-bearing Palm, is an instance of the considerable secretion of wax by a vegetable. Mr. Hardy has been attacked in various French journals for his unwise championship of this novel product; but with a persistence either the result of constitutional proclivity, or because warranted by the facts which he has actually arrived at in his Algerian experience, he writes to Count Gasparin that he desires his investigations to be remembered, and his assertions to be put on record for future reference, that he is more convinced than ever that the wax of the sorgho will indeed be one of its most valuable products.

SORGHO PAPER.

In the books of M. Duret and Dr. Sicard are pasted specimens of paper, respectively obtained by them from the pulpy sorgho stalks, of which that in Dr. Sicard's book is, I think, the best. It presents the appearance

and texture, to a great extent, of fine parchment, and is naturally sized, so that it is pleasant to write upon. It is quite strong, and for that reason suitable for wrapping paper. Of it he says, excusing himself for its unfinished quality, "I think it better to give this product in all its primitive purity, rather than to color it. Its composition presents doubtless defects, which explain themselves easily when it is remembered that this paper has been made by a person entirely unacquainted with paper-making, in want of all objects necessary for this industry, and aided simply by my little son; it will be understood by the result obtained, how much can be obtained under proper conditions from this plant."

Duret gives the process for making paper from corn stalks, as follows: "One hundred and twenty-five pounds of pulp of the stalk, which is yet moist, and from which the saccharine matter has been separated, are put in a copper, with about fifteen pounds of quick lime and a sufficient quantity of water to form of it a sort of clear paste. The mixture is moistened from time to time, and after several days of contact the pulp is triturated in a cylinder mill, as is the custom with common rags. After having reduced into paste the residue of the stalks, as we have just explained, it was mixed with twelve and a half pounds of paste of coarse rags, and the mixture was then submitted to a new trituration. This one hundred and twenty-five pounds of the stalk mixed with twelve and a half pounds of coarse rags have yielded sixty-three pounds of wrapping paper, well sized.

M. Hudelist thinks that, with fifty per cent. of common paste, he could have obtained a paper very strong

and very well sized, by giving no more care to the trituration than in working on rags.

M. Felix Vospette has also made paper with the stalks of corn by a process analogous to the preceding; but in place of ten per cent. of the pulp of rags, used in the experiment made by M. Hudelist, he made use of twenty per cent., and has obtained, with but little trouble, the same proportion of paper. If, in the place of using his corn pulp moist, that is to say, immediately after it had been pressed, he had let it dry before turning it unto paper, it would have been necessary to boil it to resoften it, and submit it afterwards, as we have above mentioned, to the successive action of lime water and of the cylinder. The paper made by M. Vospette is pliant, close in texture, very solid, of a pale shade, and made without other odor than that of the stalk from which it was made; it is naturally sized, for, in writing on it, it is impenetrable to common ink.

The quire of twenty-five sheets weighs one pound six ounces; consequently the ream, which has twenty quires, gives a weight equal to twenty-seven pounds. The pulp of the stalks loses by desiccation nearly two thirds of its weight. Twenty pounds of this pulp, very dry, produced twenty pounds twelve ounces of manufactured paper. There would then be an advantage in making cornstalk paper with the moist pulp, which would be impossible in a large manufacture, where the mass of matter to be worked up should be dried in order that it might be manufactured as it was wanted. For the military service, cartridges have been made with this stalk paper, and it has been proved that it resists humidity

more, and is less combustibile than that which is usually employed for the same purpose.

As yet, of course, no experiments have been made in making paper from the sorgho stalks in this country, but from the specimens in the books of Dr. Sicard and M. Duret, I think it possible that our manufacturers will apply themselves to experiments in this respect, and doubtless improve upon the results of the French investigators.

Thus, through all its different aspects, have we traced this wonderful plant; which, although so lately introduced, has created such very general interest with those who have had any experience in its cultivation. It now only remains for me to present the result of my labors to the American farmers and planters, and to express the wish that the Chinese Sugar Cane may realize the flattering promise which it now gives, and prove itself worthy of adoption into the list of our most valued economical plants.

CHAPTER IX.

LEONARD WRAY, OF LONDON, *England*. Letters Patent, No. 17,713, Dated June 30, 1857. Patented in Belgium, June 20, 1854.

To all whom it may concern:

Be it known unto all men, that I, Leonard Wray, of the City of London, in the United Kingdom of Great Britain and Ireland, have discovered a new process or method of making crystallized sugar, syrup and molasses, from all the African and Chinese varieties of the "*Imphee*" or "*Holcus saccharatus*" of Linnæus, often denominated "*Sugar millet*," "*Sorghum saccharatum*," "*Sorgho sucré*," etc.; which process is also applicable to the manufacture of the same products from the juice of the maize, broom corn, the sugar maple, etc.

The process constituting my said invention, may briefly thus be stated: I take the stalks of the said plants, and obtain the juice contained in them by any ordinary and well known method. This raw saccharine juice I then treat with lime, or cream of lime, until it has lost all trace of acidity, and even becomes sufficiently alkaline to affect, in a slight degree, turmeric paper, or other equally sensitive test paper; when I at once remove the said juice into a suitable filtering or other apparatus for separating the feculencies or coagulated matters from the juice, so as to obtain a clear bright liquor or juice, without having subjected it to any heat whatever. This

clear bright juice or liquor, I then put into a suitable vessel, and apply heat until the temperature rises from 120 to 180 degrees Fahrenheit, when I treat it with a dilute infusion of powdered nut galls, or other substance containing tannin, neutralizing any excess of tannin that may have been accidentally given, or any acid which may have become liberated, by the addition of a little lime, cream of lime, or lime in any other suitable combination; I then urge the heat until the liquor has arrived at the boiling point, at which it should be kept for a few moments, when the heat is withdrawn, and the liquor is again filtered and rendered clear.

This clear defecated liquor is next evaporated, and if in open pans, the scum is taken off as it rises, and the evaporation is continued, either in open pans or in any *low temperature* apparatus, until the liquor is sufficiently concentrated to permit of its granulation or crystallization taking effect in proper receptacles, into which it is placed for that purpose. If it should so happen, that the said concentrated juice exhibits a disinclination to granulate or form crystals, then the addition of a few ounces of well grained dry sugar may be had recourse to, which will immediately cause a granulation of the concentrated syrup. It must be well understood, that I make use of *charcoal once, twice, or thrice*, in the filtration and decolorization of the juice and syrup; or, on the other hand, I do not use it at all, just as I may see fit and expedient. When the new sugar is properly granulated, its molasses is separated from it by the usual methods now employed.

It must be distinctly understood that the mere idea of cold filtration is not unknown, because numerous attempts

have from time to time been made to filter the raw juice of the sugar cane, before applying heat thereto, and small quantities of lime have been put into the said raw juice, before filtration, in order to prevent the acidification and fermentation of the juice during filtration, and before it could reach the *boilers* and be boiled; but my distinct and well proved method, is that of adding lime, or cream of lime, to the raw juice until it loses all traces of acidity, and it becomes sufficiently alkaline to affect slightly the color of turmeric paper, or other equally sensitive alkaline test paper. The chemical principle involved in this process, I will now explain, so as to demonstrate the very peculiar and distinctive character of my treatment; distinguishing it, therefore, from all other methods.

The juice as it comes from the mill, I have always found to be palpably *acid*; the *first* effect of the lime, therefore, is to neutralize the juice; secondly, to regulate (by a further addition of lime) as large a quantity of the feculencies as possible, by saturating the acids which hold them dissolved in the juice. When the lime has in this manner combined with the acids, and liberated the feculencies, whatever lime may be in excess, tends to make the juice *alkaline*, which the turmeric paper immediately denotes, showing the necessity of *instant* filtration, which yields a beautiful clean, clear bright juice, *without any heat having been used*, leaving in the filtered juice, besides the sugar and water, only a little *dextrine*, caseine and *saline* matter. By this simple process, a host of troublesome albuminous, glutinous, gummy, waxy, and mucilaginous matters combined under the general head

of *feculencies*, are got rid of entirely, before they can act injuriously upon the sugar contained in the juice, which they infallibly do the moment we apply *heat* to the undefecated mass. Having thus obtained this bright raw juice, I next treat it in the manner already specified, with heat, infusion of nut galls (or other analogous substance containing tannin,) and cream of lime, lime water, or other suitable combination of lime, and then filter, so as to get rid of the *dextrine* and *caseine*, or as much of them as is possible, previous to subjecting the juice to continuous heat.

The mere idea of using an infusion of nut galls or other tannin substances in sugar making, is not new; inasmuch as these substances have been recommended and even been tried by W. J. Evans, M. D., of London, in whose work, the "Sugar Planter's Manual," (1847,) it may be found at page 101; but it will be at once observed, that the manner of employing it, or them, as laid down therein by Doctor Evans, is ENTIRELY DIFFERENT from my own method; for he applies the infusion of nut galls to the *raw green* juice in the clarifier, just as it comes from the mill, and *previous* to any other defecation having taken place. Whereas, I, on the contrary, first *defecate* the *cold raw green* juice, by means of lime, cream of lime, or other suitable preparation of lime, (as herein before set forth); and then filter the juice so treated, thereby getting rid of the great mass of green feculent matter contained in it, and obtaining a clear, bright and almost colorless juice or liquor, previous to applying any heat whatever, and previous to the venturing upon any application of the infusion of nut galls or other tannic

substances; thus forming a totally distinct method of using and applying the said tannic substances to the juice.

My process, therefore, consists *first* in the cold defecation of raw juice by means of lime, or other suitable combination of lime, immediately followed by filtration, as hereinbefore particularly detailed; and *secondly*, the treatment of the clear bright juice or liquor resulting from this cold defecation, with infusion of nut galls or other suitable tannic substances, aided by heat in suitable vessels and subsequent filtration, as hereinbefore described: together, making as a whole, one plain consecutive process, which I have herein fully and faithfully explained and set forth; and which has never been suggested nor employed by any one else before.

These comprise the whole of my treatment; and I submit that they constitute an entirely distinct and new process, being one whereby excellent crystallized sugar has been, and can always be made from the plants I have before named. And I therefore claim the process, as herein set forth, and desire to secure the same by Letters Patent.

L. WRAY.

CHAS. L. ALEXANDER, }
THOMAS C. CONNOLLY, } *Witnesses.*

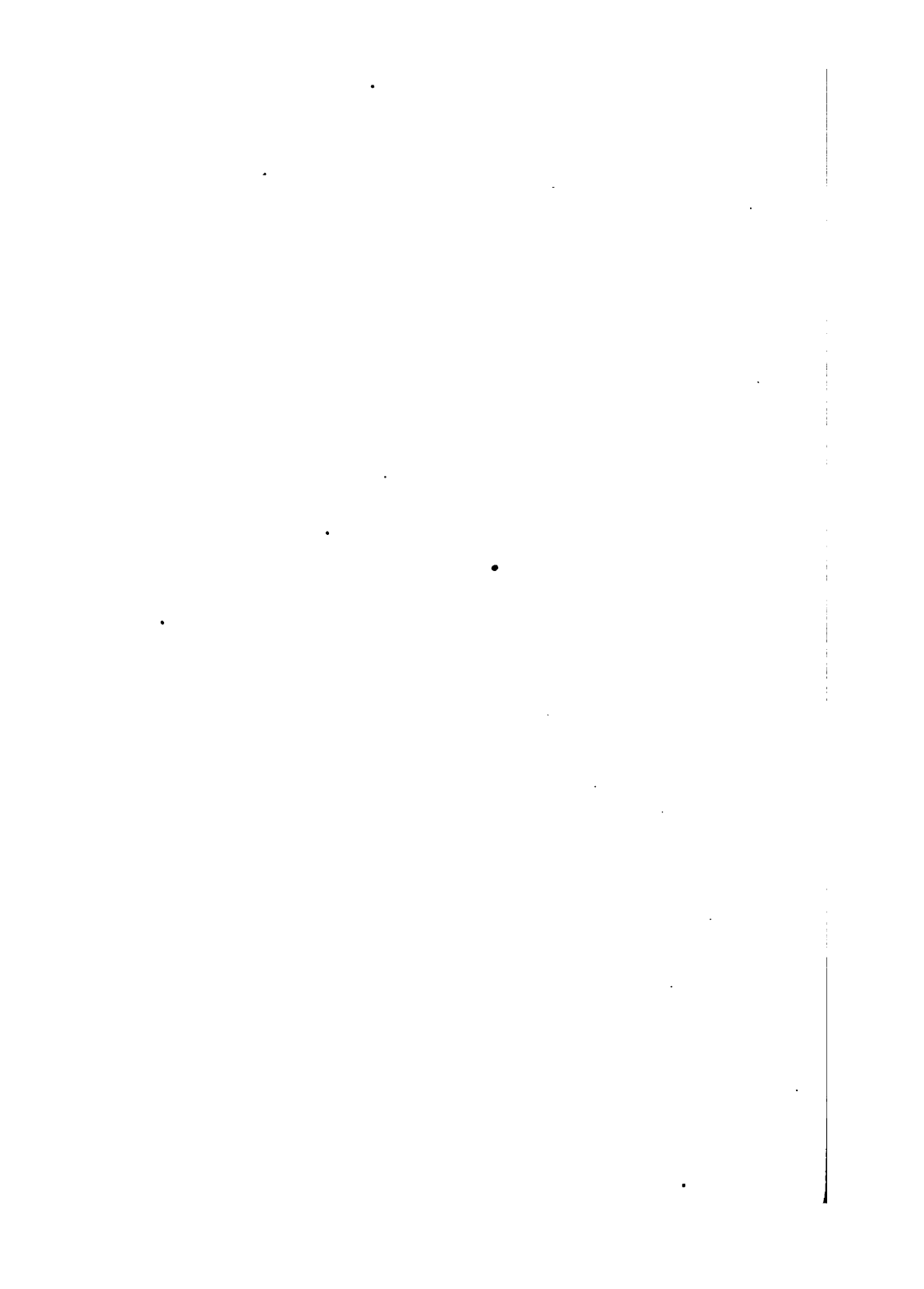

PART II.

THE

ZULU-KAFFIR IMPHEE,

OR,

“SWEET REED,”

(THE *Holcus Saccharatus* OF LINNÆUS.)

COMPRISING A DESCRIPTION OF ITS NUMEROUS VARIETIES, ITS MODE
OF CULTIVATION, AND THE MANUFACTURE OF SUGAR
AND OTHER PRODUCTS FROM ITS RICH
SACCHARINE JUICE.

BY LEONARD WRAY,

AUTHOR OF “THE PRACTICAL SUGAR PLANTER,” “THE SUGAR PLANTER’S
COMPANION,” ETC., ETC.

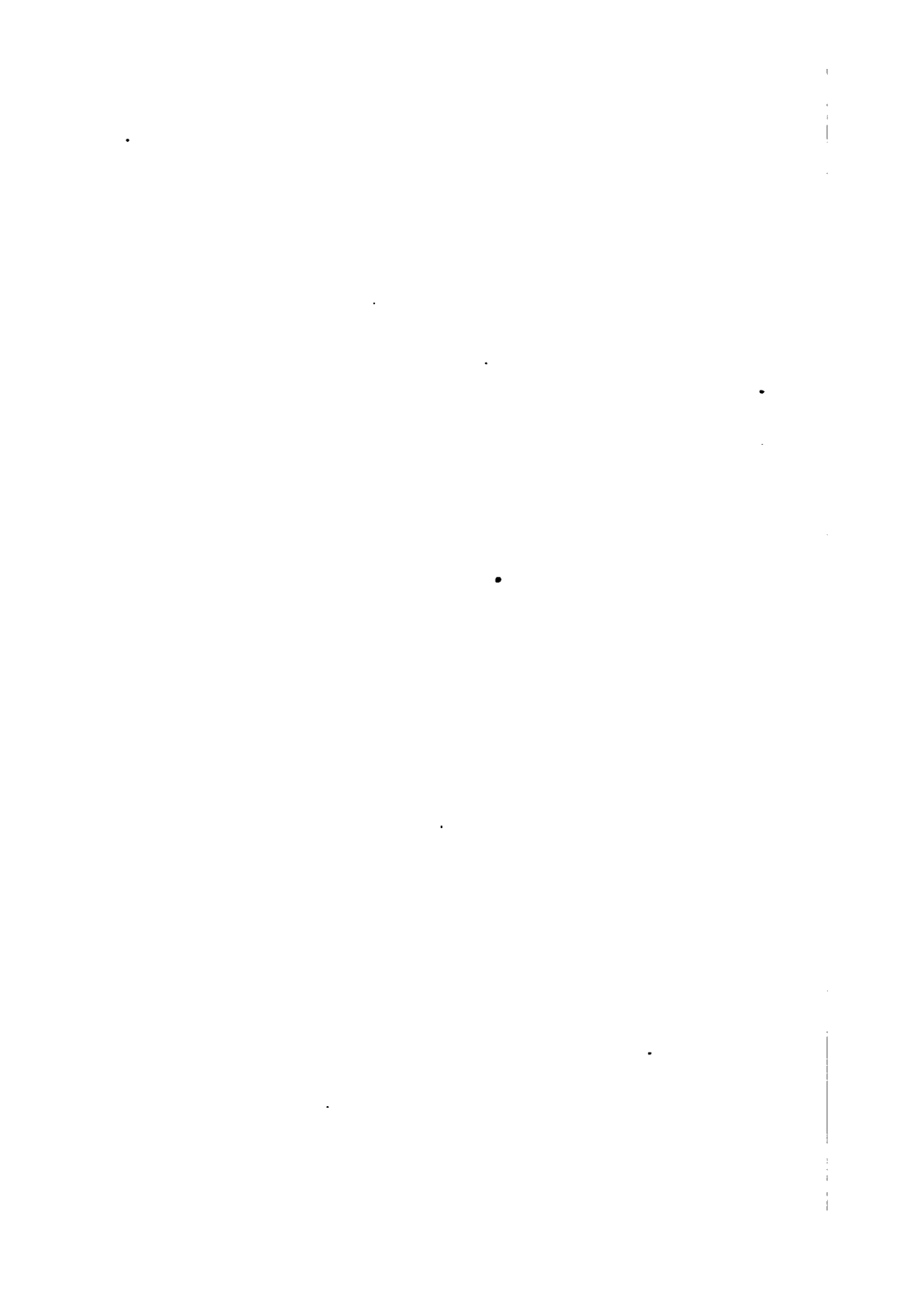

THE IMPHEE,

OR

AFRICAN SUGAR CANE.

THERE can be no question that many useful arts and manufactures, known and practiced by the ancients, have, from certain untoward causes, been lost to the world, and continue so to this day. Many, again, have been rediscovered from time to time, and are thus restored to the present generation; holding rank, however, more frequently in the character of *new* and *original* discoveries and inventions, than as mere restorations to human knowledge.

Not a few have been restored to us by purely accidental circumstances; others have been strictly the discoveries and inventions of practical and gifted men of modern times, the results of sagacious observation, skillful experiments, and practical deductions, apart from any previous traditionary ideas on the subject; whilst others, again, have been the valued reward of intense study and unwearied endeavors to obtain those results which *tradition*, or perhaps, even existing specimens, told them had been accomplished in bygone ages, and by which they were incited to attempt their rediscovery.

Amongst the many, two articles, namely, *glass* and *iron*, suffice to furnish us with numerous familiar instances of lost processes rediscovered; and even of lost manufactures not yet restored to us, although sought after by many really practical men. We may, moreover, go beyond these remarks, and assert that there are *some*, if not *many*, arts and manufactures known and carried on by the Chinese, which certainly are not understood and practiced by Europeans.

Not a few of their simple inventions and ingenious contrivances are either totally unknown to us, or if slightly mentioned by travelers rather more observant than others, their accounts have been so inaccurate and deficient in detail, that the principle and consequent value of these inventions have remained unappreciated and unadopted.

Who would be so hardy as to assert that much valuable knowledge in various particular branches of art (of which we ourselves are ignorant) does not exist in the islands of Japan? I fancy that no reasonable man would venture upon such an assertion. All this serves to teach us, that in bringing forward anything as a NEW DISCOVERY of our own, we must not be disconcerted if, on careful examination, we find that we are, in reality, merely rediscovering, and giving to our own generation and country, in a practical form, that which has been known and attempted, if not actually used, in by-gone times; or perhaps by a far distant and scarcely known people of our own day.

It is a principle, however, most wisely recognized by the law of almost every civilized nation of the present age, that

any individual making such a rediscovery, or reinvention, or even introducing a useful invention, so as to *utilize* or turn it to a useful purpose, should be, to all intents and purposes, entitled to the benefits and advantages accruing from a patent, or protective grant, during a period of years, varying according to the laws of the different countries wherein such patent is granted.

Were this wise and enlightened view of the case not taken, how many hundreds of useful and important discoveries and inventions would now still continue hidden in the dormant state to which, in ages past, the accidental death, even the poverty, of the original inventor and discoverer, a slight mischance, or a local difficulty, might perhaps have consigned them. We even see, in our own day, how many really useful inventions are suffered to languish and become inoperative for lack of energy, want of encouragement, &c., or the thousand and one chances and obstacles to the successful introduction of modern improvements and inventions. We can well understand, therefore, how strongly all these, and other causes, may have operated in less advanced, less enlightened, and less enterprising ages.

I have been led to these few introductory observations by the reflections which have been forced upon my mind within the last few months, whilst following up the subject matter involved in the history of sugar manufacture, from the earliest records to the present day; and of the plants from which the natives of various countries extracted a kind of sugar or *jaggery*, before the sugar cane was so universally diffused over the globe.

In the year 1847, whilst I was engaged in writing my

work, "The Practical Sugar Planter," my mind became strongly impressed with the idea (an impression almost amounting to conviction) that "the reed," the "sweet reed," so frequently made mention of by ancient authors as being used by the natives of Morocco, Ethiopia, Egypt, Arabia, and India, for the purpose of making sugar or jaggery, did not really in all cases mean, or apply to, the sugar cane, but that some other reed-like plant was more particularly referred to, which in process of time had been gradually displaced by the true sugar cane. But with no satisfactory authority, and with no corroborative evidence to support the idea I had formed, it by degrees lost its hold upon my mind, and eventually was scarcely remembered. However, on visiting a colony in Natal, in Africa, in 1851, I found there, in the plant called by the Zulu-Kaffirs *Imphee*, "the sweet reed," which might well have been alluded to by the ancient writers. My mind, at that time, was so occupied by other subjects, that I paid but small attention to this interesting plant, and some time elapsed before I directed my thoughts to it, and thus became aware of its immense importance to Europe and America, and, indeed, to the world at large.

I heard that some very intelligent colonists had tried to make sugar from its rich juice, but that they had, one and all, entirely failed in doing so.

No way discouraged, I sent my most intelligent Kafir servants long distances to collect me seed of all the different kinds of *imphee* known amongst themselves, and thus obtained fifteen kinds, more or less differing from each other, but all known under the general native name

of *Imphee*, and comprised in botany under the name *Holcus saccharatus* (Linnæus.)

All of the seeds I planted, and made sugar from the whole fifteen different kinds, which enabled me to ascertain not only the saccharine value of each, but likewise the distinct peculiarities of the growth, seeding, etc., etc.

The results of my observations and long-continued study of their habits and relative value will be found in the succeeding pages; but my manufacture was so completely successful, that I left Natal and came to Europe to prosecute my discovery, and introduce to the notice of the world the vast importance of the plants for sugar manufacture.

In recently looking over various botanical works, I find that attempts have been made by Signor Arduino and others to introduce varieties of this plant into European cultivation, for the purpose of making sugar, but from some cause or other they had hitherto been perfectly unsuccessful.

Nor am I any way surprised at these failures, believing that its success in Europe very essentially depends upon the particular kind of imphee that is planted, and the next, upon a peculiar method employed in treating the juice.

I also find it stated that the inhabitants of northern China use it in making a kind of sugar.

This really may or may not be the case, for, in point of fact, almost the whole of northern China, together with the major portion of the great interior of that immense empire, may be fairly denominated a *terra incognita* to us; a country so effectually sealed up, that, as I before ob-

served, numerous arts and manufactures may be there existent at the present moment, which are nevertheless wholly unknown to us, or perhaps have been heard of only through the medium of unauthenticated and unsatisfactory rumors.

In the manufacture of crystallized sugar, and other products, from the imphee and *Holcus saccharatus*, I have had the most signal success, and in the following pages I will endeavor to set the value of these plants in a true light before the public, hoping very soon to present to the attention of my kind readers, a much larger and more comprehensive edition of this work.

BOTANICAL NOTICE AND HISTORY.

It is indeed most difficult for me, *not being a botanist*, to give a botanical description of the Zulu-Kaffir *Imphee* that could be deemed altogether satisfactory; for, after the most careful research among the best botanical works, and after consulting very eminent botanists personally, I can come to no other conclusion than that the most singular uncertainty and confusion reign among them all in their several accounts of this species, arising, evidently, from the fact of no sufficiently competent botanist having yet thoroughly investigated the differences existing between the several kinds of imphee and the several kinds of *Mabaalee* or Kaffir corn.

This lamentable state of things will, however, be terminated, I trust, in a few days, as I have now flowering in England *three* kinds of real imphee, besides my dried specimens, which will enable me to obtain from Dr.

Thompson (a distinguished botanist) their true botanical description; although we certainly have no plants of the Kaffir corn, or Guinea corn, with which to contrast them.

I will, however, venture to say, that I entirely agree with Linnæus, Brown, and others, in the botanical name which they have bestowed upon the Imphee, namely, *Holcus saccharatus*, the Kaffir or Guinea corn being *Sorghum vulgare*, or *Sorghum halapense*, or *Sorghum andropogon*, as its several kinds are called by various authors.

In a work entitled "Hortus Americanus," published very many years ago, in Jamaica, by Dr. Barham, the *Guinea corn*, so universally cultivated in the island for its grain, is described as "*Holcus Sorghum*, or *Sorghum vulgare*; native habitat, Coast of Guinea, Africa; natural order, *Graminea*; class, *Polygamia*; order, *Monœcia*;" and the general account therein given of it agrees in every respect with my own observations.

Many other sorts of the same grain are grown by the Zulu-Kaffirs, on the south-east coast of Africa, but are all comprised under the one general name of *Mabaalee*, although much difference exists between them, not only in the peculiarities of the *seed-heads*, etc., but likewise in the juice of the stalks, being slightly sweet in *some*, whilst in *others* scarcely a trace of sweetness can be detected. They are all cultivated for their *grain*, and for that alone; whereas, the imphee, or *Holcus saccharatus*, is grown only for its sweet juice, and *never*, to my knowledge, for its grain, which the Kaffirs say cannot be used as human food, in explanation of which I must state that they never grind their *Mabaalee* to extract the flour, but boil it whole,

in which form they consider the grain of the imphee to be highly deleterious.

The great and *essential* differences really existing between the *Sorghum andropogon* and the *Holcus saccharatus* are certainly not those unluckily relied upon by some of our modern botanists, and shown in the following:

“ But most botanists seem to agree that there are only *two main types*, to which all the others are subordinate. *Sorghum vulgare* has an oval, rigid, more or less compact, panicle or head of flowers, with ascending branches, while *Sorghum saccharatum** has a loose panicle, with lax, elongated, weak, and sometimes pendulous, branches.”

For at least *three* or *four* sorts of imphee, namely, *Koom-ba-na*, *Shla-goon-dee*, and *Oom-see-a-na*, have panicles as *rigid* and *compact*, with branches erect, and as short and stiff as can well be.

The “*two main types*,” therefore, are entirely fanciful and valueless, forming no criterion whatever.

Another writer says: “Millet seed, the produce of *Holcus saccharatum*, is imported largely into this country (England) from the East Indies, for the purpose chiefly of making puddings; and by many persons it is preferred to rice.” Of this I may simply say, that it is nothing of the kind; it is quite a different millet.

To make confusion worse confounded, some botanical writers likewise call the broom corn, *Sorghum saccharatum*, making upon the whole a nice medley of those really simple distinctions.

In spite of all these scientific complexities, however, I think we may safely hold the imphee (of all kinds) to be

* Meaning, of course, *Holcus saccharatus*.—L. W.

actually the *Holcus saccharatus*, a perfectly distinct tribe of plants, and *not a Sorghum at all!*

It is said that seed of this plant was introduced (for what purpose is not stated) into England in 1759; but seeing the botanical confusion existing on the subject, I very firmly disbelieve it, and consider that it was much more likely to have been some kind of sorghum, introduced for the sake of its grain.

There can be no doubt, however, that Professor Pietro Arduino, of Florence, became acquainted with one or more sorts of the *Holcus saccharatus*, perhaps as early as 1766; and 1786 he published an account of his experiments in sugar making from it. It would seem that he endeavored to establish its cultivation in Tuscany; but for causes which have never been clearly given, he did not succeed in doing so.

From his time, it may be said to have remained in total obscurity, (as far as Europe is concerned,) down to the year 1854.

So much has this been the case, that although I have been a sugar planter so many years of my life, and have, as an author, had to look closely into all information connected with the production of sugar, in both ancient and modern times; yet I can truly say, that I knew nothing of this plant until I resided in the colony of Natal, on the south-east coast of Africa, where it grows in abundance. Nor was it until I reached England this year, that I could obtain the works of scientific authors, from which to learn its botanical character, and what efforts had been made, if any, to introduce it to notice.

It was with the utmost difficulty that I was enabled to

obtain the whole *fifteen sorts of imphee* that I now have; and I never should have acquired anything like accurate knowledge of the individual peculiarities and value, had I not cultivated them on a sufficiently large scale; thoroughly studied them during their growth, and ultimately made a large quantity of sugar from them. The seed I obtained from this cultivation, I have now in England with me; and it is capable, with care, of planting some hundreds of acres. Some plants grown in England this year, have already ripened their seeds, which are full and plump.

I have grown it in Belgium and several other parts of the continent this year, and it has succeeded remarkably well.

But if we look back from our own times to very remote ages, and search for any very authentic records of the imphee or *Holcus saccharatus* among the writings of ancient authors, we must confess the unsatisfactory result of our inquiry; for the notices of the "sweet reed," contained in their writings, have long ago been seized by Porter and other authors, and appropriated by them as forming part and parcel of the history of the *sugar cane*.

But if we examine somewhat minutely into the matter, we shall find abundant reason for believing that the *Holcus saccharatus* was frequently alluded to instead of the sugar cane, more especially by the Roman writers; thus Lucian, (Book iii, page 237,) has the line—

" Quique bibunt tenerâ dulces ab arundine succos."*

which can scarcely be supposed to apply to the *large, coarse, hard stock* of the sugar cane.

* " And those who drink sweet juices from the tender reed."

Besides this, we all know that the Romans had a very excellent general knowledge of the products of Ethiopia, in which varieties of the *Holcus saccharatus* are to be found; and they, no doubt, knew that the natives ate, or rather chewed, its stalks, for the "sweet juices," contained in them.

The native traders who took a coarse kind of *goor*, or *jaggery*, to Muciris and Ormus, always said that they obtained it from a "reed;" and I have no doubt that they did really obtain it from this reed-like plant, until the sugar cane superseded it in their estimation, and was cultivated in its stead.

I could enlarge much upon this interesting question, had I the space to do so; but the confined limits of this treatise compels me to bring this chapter to a conclusion as soon as possible.

I venture to consider the *Holcus saccharatus* as the connecting link between the sugar cane and the grain-yielding sorghums; and so strong an impression did my mind receive when I first saw the extremely tall "Vim-bis-chu-a-pa" and "E-a-na-moo-dee,"* that I almost persuaded myself that they were in reality *hybrids*, between the sugar cane and the Kaffir corn (*Sorghum vulgare*.)

Such, however, is not the case; but it remains to be

* The two largest of the imphee kind.

Note.—Wilkinson says, that the *Holcus saccharatus* (Arabic name *Dokhn*.) is grown about Assouan, in Nubia and the Oasis.

Of sorghums, there are, in Egypt, six kinds, namely, Doura sáyfee, or baalee; D. humra, D. kaydee, D. byood, or diméree; D. owayyoh, D. saffra.

seen whether we can, by adopting proper measures, obtain hybrids between the imphee and the sugar cane.

DIFFERENT VARIETIES OF THE IMPHEE, ETC.

I am acquainted with fifteen varieties of the *Holcus saccharatus*, although I doubt not there are yet others in different parts of the world that have not come under my notice.

I shall, therefore, confine my remarks to the fifteen varieties; and to prevent the constant repetition of their botanical name, I shall, throughout these pages, use their Zulu-Kaffir name of Imphee alone.

Among Europeans residing in South Africa no distinction is known in regard to the varieties, and there they will be much surprised at learning that there are really fifteen different kinds of imphee growing before their eyes, and constantly being eaten by them.

There is certainly that degree of similarity between them when seen growing together which is quite sufficient to puzzle any one who has not thoroughly studied them; and this is so much the case that there are very few *male* Kaffirs even who can discriminate between some of the varieties; in consequence of which I had very frequently to call in the superior agricultural knowledge of the old Kaffir women, until I had learned to distinguish between them with certainty myself.

When I had attained this first most desirable step, I had next to learn their several peculiarities and value; which I was able to do with greater exactness by planting the seed, watching them daily during their growth,

and eventually testing the saccharine value of their juices, and making sugar from them all in large quantities.

“*Vim-bis-chu-ā-pā*.”—This is the largest size, and the tallest of the whole; whilst it is full of juice, and very sweet. When planted in rich alluvial soil it attains its greatest size and most perfect development, requiring from four to five months to arrive at maturity. It grows to a height of from ten to fifteen feet, is from one and a half to two inches in diameter at the lower end of the stalk, and usually cracks or splits as it ripens. By means of a most primitive and ill-constructed little wooden mill, I obtained sixty per cent. of juice from the stalks. This juice was clean and clear, and the saccharometer showed it to contain fourteen per cent. of sugar, after I had removed the feculæ by means of cold defecation. The sugar it yielded was fully equal to the best cane sugar of the West Indies. The stalks, carefully weighed, were found to vary from one and a half to two and a half pounds English weight each, trimmed ready for the mill. The seed-head, which is very large and beautiful, is generally from twelve to eighteen inches in length, containing many thousands of fine plump seeds, of a sandy yellow color, strongly held by a sheath which partially envelops them.

“*E-ā-nā-moodē*” is the next in size, and is very similar, both in habit and value, to the last. It attains a height of twelve to thirteen feet, but is not so coarse in appearance, nor does it contain so much woody fiber as the *Vim-bis-chu-a-pa*, but it is rather softer and more juicy, I having obtained from it sixty-four per cent. of

juice, containing fourteen per cent. of sugar. The stalks weigh from one to two pounds when trimmed ready for the mill, and I have cut as many as eleven such stalks from one root or stool. The seed-heads are large, but stiff and erect, containing quantities of large round, plump seeds, of a clear yellow color. In general, they may be said to ripen two weeks earlier than the last named. Like the Vim-bis-chu-a-pa, this variety ratoons in about three to three and a half months after the first cutting.

“*E-éngha*.”—This is a fine, tall kind, being from ten to twelve feet high when full grown, but it is more slender than either of the foregoing, and exceedingly graceful in appearance. It begins flowering in ninety days, and is fully ripe three weeks after; we will therefore class it at four months. I have had stalks weighing as much as one pound fourteen ounces each. The largest commonly obtained may then be estimated at two pounds weight; yielding, by my poor little mill sixty-eight per cent. of juice, containing fourteen per cent. of sugar. I have obtained ten stalks from one stool. They ratoon in three months after cutting. The seed head of the *E-éngha* is large and very pretty, the seed being upon long slender foot stalks, which are bent down by the weight of the seed, forming a graceful drooping. The seeds, which are of a dull, yellow color, are rather long and flat than round and plump.

“*Nee-ǎ-zā-nǎ*” is held, by the Zulu-Kaffirs, to be the sweetest of all the imphee kind; but I found the *Boomvwa-na* and the *Oom-see-a-na* quite as sweet, and, in my estimation, their juices are superior to it in some

points. My Zulus have told me, that under favorable circumstances, the Nee-a-za-na frequently ripens in seventy-five days; and my head man (a most intelligent native plowman) declares that he has had them from his own land as sweet as any sugar cane. From my own actual experience, I found that they ripened in about three months, and that they were the softest and most abounding in juice of any. With my mill I obtained seventy per cent. of juice, much still remaining in the trash, and the saccharometer showed fifteen per cent. of sugar after cold defecation. This then for European culture, is a perfect gem of a plant, one which will be anxiously sought after, and very generally cultivated, throughout Europe at least. In two months after the first cuttings, I have had the ratoons six feet high and in flower. The Nee-a-za-na is a very small sized variety, but tillers out greatly, having sometimes fifteen stalks for one root. I have had its stalks varying from four ounces to upwards of twelve ounces in weight; but they *do* grow rather larger than this. It always appeared to me that their juice was more mucilaginous and abounding in feculæ than the two varieties I have just mentioned. The seed-head is very bushy and bunchy, and when thoroughly ripe, the seeds are large, round and plump.

“*Boom-vvā-na*” is a most excellent and valuable variety; of which I have eaten single pieces, containing certainly two or three per cent. more sugar than the average juice obtained from large bundles of stalks, taken as they come. This average juice never contained less than fifteen per cent. of sugar, as indicated by the saccharometer, after the raw juice had been cold defecated; and

there is a clearness, a brightness, and a genuine sugar-cane sweetness in the juice of this variety, and of the Oom-see-a na, that I very much admire. In its growth and general appearance, it is very much like the E-en-gha; but its stalks are brighter and more slender: its leaves are not so broad, and its seed vessels are upon shorter and stiffer foot stalks. The stalks have a pinkish red tint, which increases as they approach maturity, and the seed cases have a pink and purple hue mixed with the general yellow ground. The Boom-vwa-na tillers very much, giving from ten to twenty stalks for one root, but they seldom weigh more than one pound each. I have obtained seventy per cent. of juice, which is easily clarified, and makes a beautiful sugar. The plant reaches perfection in from three to three and a half months.

"Oom-see-ā-na" is a peculiarly marked variety, in consequence of the purple or black appearance of its seed-heads, arising from the *sheath* or *seed cases* being of this color, and not the seed itself. The seed head is very stiff and erect, with short, strong foot stalks, and the seed is large, round, and full. In time of growth, and goodness of juice, it is very similar to the Boom-vwa-na; its stalks are small, but numerous. They both ratoon well, in three months, from first cuttings.

"Shla-gōōva" is slightly inferior to the three last mentioned varieties, but is nevertheless very valuable, and much prized by the Zulus. It takes three and a half months to ripen, and becomes a tall, good sized plant; but its chief distinction is the exceeding beauty and elegance of its seed heads. The foot stalks are extremely long, which causes them to have a graceful drooping,

while the seed cases or sheaths, vary in color from a delicate pink to a red, and from a light to a very dark purple, but each color very bright and glistening, forming on the whole an extremely beautiful appearance."

"*Shla-gōō-ndee.*"—This is a sweet and good variety, and under favorable conditions produces fine sized stalks. The seed heads are very stiff and erect, and the seed vessels are compact, and very close. It usually takes three and a half months to reach maturity, and it rattoons very quickly, as the following memorandum of my diary will show :

"December 13th. Cut down a small patch of imphee, and dug up the ground for the purpose of planting arrow-root, but some of the imphee not being entirely eradicated sprung up afresh, some roots having fifteen stalks each. On the 18th of February, one of them (*Shla-goon-dee*) was upwards of six feet in height, with a thick stalk, and the seed head just thrown out, *being only two months and five days* from its being cut down and apparently destroyed." This bunch of seed I gathered during the first week in March, and I have it now in England.

"*Zim-moo-mā-nā.*"—This is likewise a sweet and good variety, with seed heads upright and compact, and fine plump seeds, very numerous.

"*E-both-la,*" "*Boo-ee-āna,*" "*Koom-ba-na,*" "*See-en-gla,*" "*Zimba-zā-na,*" and "*E-thlo-sa,*" form the remainder of the fifteen varieties, each differing slightly from the others in its saccharine qualities as well as in appearance, but still easily distinguished from each other by any one who has studied them. I do not see the necessity of entering at present into further detail in regard to the

shades of difference, as the larger edition of this work will contain all such particulars.

I have before remarked, that *all* the varieties are known (from the Cape Colony to Delagoa Bay) under the general Zulu-Kaffir name of *Imphee*, which name is likewise generally used by the Europeans, who sometimes also call it *the Kaffir Sugar Cane*, from the circumstance of the Kaffirs growing it round their kraals, to eat, as they do the real sugar cane; but I never met a single European who could tell one description of *imphee* from another, not even among those who have been in the Colony ten or twenty years.

The following points are particularly striking, namely

- 1st. The Zulus *never* (to the best of my knowledge and belief) cultivate it for its grain, or for any other purpose than for its sweet juice, which they obtain by chewing the stalk.
- 2d. Whilst ripening its seed the birds never attack it, whereas it requires great vigilance to preserve the seeds of the Kaffir Corn (Guinea Corn) or *Sorghum vulgare*, from their pertinacious voracity. So much is this the case, that I do not think I lost a single seed from the birds, whilst from the Kaffir Corn there is no keeping them off. The Kaffirs say this is always so.

As the Kaffirs cultivate the *imphee* merely for its juice, they never allow any more to ripen than is necessary for the next year's planting; but soon after the seed head appears, they pull it off, by giving it a smart jerk upwards. By this means they argue that the plant perfects the elaboration of its juices and becomes much

sweeter, instead of forming seed at the expense of its saccharine matter.

This, no doubt, is to a certain extent perfectly reasonable, and would be very successful, *if the plant could be prevented from expending its saccharine strength in its natural efforts to reproduce itself*, but so imperative is the great law of nature that immediately the seed is removed, the eye or bud belonging to every joint along the stem begins forthwith to swell, and in a few short days will have shot out a foot or more in length, crowned with small seed heads, having three or four, some three to six, side-shoots with seed heads along the stalk, to replace the one main head removed.

My own experience therefore led me to doubt very much the expediency of thus running counter to nature's laws; and eventually I abstained altogether from removing the seed heads, fancying that I gained rather than lost in saccharine quantity by my noninterference. I then removed, in many instances, these eyes with my penknife, but the plant forthwith sent up a number of fresh sprouts from the roots to balk me, so I gave it up. A knowledge of this fact is very important in studying the subject of ratooning.

The description I have given will suffice to show the comparative value of the different kinds of imphee, and it will be apparent to the meanest capacity that the successful cultivation of this plant for sugar making in the greater portion of Europe, depends almost entirely upon the selection of the proper variety.

The capricious character of the summer in Europe is well known. Very hot and even tropical weather may

at times be suddenly varied by a few days of cold, raw, wet, and windy weather, throwing back and greatly retarding the growth of these plants, thereby changing the three, and three and a half, or four months required under altogether favorable circumstances into a much longer time, and thus perhaps obtaining really no thorough ripening of the plant after all.

But, on the other hand, if we plant only of those varieties requiring from two and a half to three months of continuous warm weather, we render the success of the cultivation as nearly certain as we well can.

The introduction of unsuitable varieties into Europe has been, in my estimation, the one great reason of their failure hitherto; and in this belief, I hold the Nee-a-za-na, Boom-vwa-na, and Oom-se-a-na to be peculiarly valuable for our European cultivation.

The imphee is a tall, slender, and very elegant plant, its foliage being light and graceful, and its tints bright and varied in the different stages of its growth. It exhales a perfume at once strong and agreeable, with something approaching that of rich new honey.

CULTIVATION, INCLUDING SOILS, CLIMATE AND SEASONS.

CLIMATE.—It may be safely stated as an indisputable fact, that wherever maize or Indian corn will grow and ripen its seed, imphee will likewise grow and elaborate its juice so as to be suitable for sugar making, bearing in mind always that in as much as the maize comprises varieties which require five months, and others which require only three months, so in like manner does the

imphee include those varieties requiring four and a half months, and others again which ripen in two and a half and three months only.

This is a very essential fact to be remembered in order to adapt in all cases the variety to the peculiar character of the locality; and I believe that no explanation, however lengthy, could more accurately define the climatic range of the imphee than simply classing it with maize in this respect.

In Northern Europe, and in numerous other parts of the world, no kind of maize can be profitably cultivated but those which ripen their seed within ninety days from planting; and it will be found that in all such localities no other variety of imphee can be successfully employed but such as ripen their juices within the same short period. But what truly enormous range does this climatic adaptation give us! It comprises, in fact, every country of the earth that can afford three months of hot summer weather. It does not even exclude Canada or Russia.

But as we draw nearer and nearer to the equator, the gradual lengthening of the summer season, until indeed winter is unknown, affords a longer and longer growing time, so that at last, instead of *one* crop, we can obtain two, three, ay, and even four crops in one year.

It is evident, likewise, that the longer the summer or warm weather extends, the greater scope exists for the cultivation of the larger and more productive varieties that require a longer time for their perfect development.

The small measure of temporary success which is said to have attended the attempts made in 1785, by Signor

Arduino, of Florence, to introduce varieties of the *Holcus Saccharatus* into European cultivation, and their ultimate failure and consequent total disuse, arose from the simple circumstance of his having unfortunately lighted upon varieties which required too long a period for their perfect maturity to suit the short and variable summer of Europe.

I cannot impress this important point too strongly upon the attention of my readers, for on it, in fine, depends the success or failure of the whole cultivation for the purposes of sugar making. In tropical climates the planter is of course free to choose whichever variety his fancy or his experience in time to come, may lead him to prefer: nor can any set rule be laid down which he must of necessity follow.

It is to be supposed that he will select those varieties which will not only yield him a large return per acre, but will afford him an extended period for his manufacturing operations, instead of all becoming ripe together.

SOIL.—Imphee will grow well and produce sugar abundantly in a great variety of soils; and in this respect it is very similar to the real sugar cane; but among the many advantages which it has over its great rival, the perfect immunity it enjoys from the attack of *white ants* is one much too important to pass over without remark.

In the colony of Natal, on the south-east coast of Africa, the white ant is as numerous, and fully as destructive, as it is in India; consequently, none but low-lying, swampy grounds can be used in that colony for sugar cane cultivation; and this fact places a restriction

upon its extensive culture in Natal, which no human art can overcome. But such an affliction does not extend to the imphee. On the contrary, the white ants (although swarming in the soil) never touch these plants. I have grown a fine crop of imphee on a sandy hill top, where it would have been utterly impossible to grow sugar cane, on account of the white ants.

This seems a small matter to dwell upon, but in reality it is of the utmost importance to Natal, India generally, the Straits (Malacca) settlements, and to every other country wherein that insect scourge exists; because it admits of sugar being produced from the imphee on millions and millions of acres which are totally unsuited for the sugar cane.

This simple fact alone is calculated to enhance the price of land in Natal and the Cape Colony to an immense extent, and it will have the same effect in many other countries.

I have introduced the subject of white ants in this place, because in trying of soils suitable for the sugar cane, it is absolutely necessary to exclude all those infested by white ants, whereas in the culture of the imphee their presence is of no consequence.

In rich alluvial soils, in good light brick mold, in loamy soils, and, indeed, in almost every good soil in which there is a fair admixture of vegetable mould, the imphee delights, and will grow famously with sufficient moisture.

Plenty of vegetable mold, strong heat and light, and considerable moisture, form the great essentials to the full development of the plant, and the perfect elaboration of

its juice, so as to yield its maximum quantity of saccharine matter.

If, after a season of long-continued showery weather, a period of dry weather occurs just as it ripens, then the juice is more especially abundant, and rich in sugar.

Soils highly manured with animal manure, or, in fact, with any which abound in ammonia and other saline substances, tend to the formation of a large, luxuriant plant, but its juice under such circumstances is so mucilaginous and saline as to render it extremely unsuitable for sugar manufacture, hence such treatment should be studiously avoided.

The same rule applies in the case of the sugar cane, beet root, and other sugar-yielding plants; and if it be violated, the result is certain to be disappointment and vexation.

MODE OF CULTURE.—I have, in some instances, soaked the seed of the imphee for twenty-four and even forty-eight hours, in warm water, previous to planting them, in order to expedite their germination, as seeds so treated will, in warm, moist weather, be up in four days afterwards; whereas, being planted (during showery weather) without this assistance, they usually take six or seven days for sprouting. If, after planting, dry weather sets in, they will, however, require ten or even fourteen days to appear above ground; but by being well soaked beforehand this casualty is materially obviated. Hence I hold the practice to be a prudent one.

The seed requires to be very lightly covered; for, if deeply set, it is liable to rot, should much rain occur

immediately after; but lightly covered, it will not be injured by even constant rain.

I have lost a great deal of seed by planting too deeply, and I shall, therefore, be very cautious never to commit the same error again. If soaked in warm water for twenty-four hours, then planted in a bed, and care taken to keep them properly moist, we may always calculate with certainty on having them an inch above ground in four days (warm weather.)

This first start is a great point wherever the warm weather lasts only a short time; but in no case is it altogether unimportant; and it becomes a question of no small moment, whether in England and some parts of Northern Europe it would not even be quite worth while to sow the seed under glass in the first instance, and then plant out the young plants, before they are a month old, in the open ground, where it is intended they shall remain for crop.

In this case, very little more labor is required than is now universally bestowed on the Continent in making the beet root nursery beds, and subsequent transplanting of the young beets. My own experience this season, in England, has shown me that even in a small greenhouse, a prodigious number of young plants may be raised without any artificial heat whatever, and the plants are so hardy that they bear transplanting admirably.

By this simple plan we get over the difficulties opposed to us in England by late frosts and cold, nipping winds, for we can commence transplanting in June, and thus allow June, July, August, and part of September, if needed, for their growth, which my experiments this

season have clearly demonstrated to be quite sufficient. If it be objected that this plan entails more than ordinary trouble, I answer it also insures the safety of a valuable crop, a consideration of no small importance.

It must be remembered that every seed will, under favorable circumstances, "tiller" out so largely as to have from ten to twenty stalks or canes (as I shall henceforth call them) forming a large stool, and occupying a considerable space.

I have found that rows three feet apart, with plants twelve inches from each other along the rows (being about 14,000 per acre), in most cases, was a very suitable distance to plant them; but the ever-varying circumstances of soil, climate, and seasons, added to the differences between the larger and the smaller varieties of the imphee, must naturally suggest corresponding differences in the planting distances.

I have had the Nee-a-za-na in rows only two feet, and again in rows two and a half feet apart; but I will not venture to say that in all cases such close planting is proper.

In planting along the rows, wherever the plants are too thick, they can always be thinned out during their early growth.

The great objection to the adoption of close rows is the very serious one arising from the difficulty of cleaning and digging between them, which is so desirable and so very conducive to their vigorous growth and perfect development; for, in common with almost all other plants, the imphee likes to have the soil loosened and moved about around its roots.

I suppose that it is almost unnecessary to observe that, although it likes abundance of moisture in the soils whereon it is growing, yet it has a decided objection to stagnant water being around its roots. As the plant progresses towards maturity, it throws up its graceful flower, which very speedily is transformed into a seed head, most abundantly covered, or rather laden, with grain.

In the last chapter I alluded to the Kaffir custom of removing these seed heads shortly after they appear, and I can only repeat the doubt I there expressed, whether, by so doing, we may not really lose more than we gain.

When allowed to perfect its seeds, the grain is generally plump and full of fine, white flour, which I believe is wholesome and nutritious, and might enter largely into general consumption.

- This, in itself, constitutes a feature much in favor of allowing it to ripen its seed; and, in a more general sense, is highly important.

Notwithstanding my numerous unsuccessful attempts some years ago to impregnate or fecundate the flowers of the sugar cane, so as to obtain a seed which would germinate and produce sugar cane, yet I cannot help clinging to this plant (imphee) as the only remaining hope we now have of effecting this interesting object. I have already taken measures to have new flowers of the sugar cane brought into immediate and continued contact with those of the imphee, so as to ascertain for a certainty whether the sugar cane will thereby be induced to perfect its seed, and, on the other hand, whether the pollen of the cane flowers will produce any beneficial or other change in the character of the imphee seed.

This is a question of sufficient interest to engage the attention of every scientific and inquiring mind, as it comprehends that which is interesting, and that which may be of great practical utility to the world at large.

When the seeds of the imphee are ripe or perfectly full, it is the custom of the Zulu-Kaffirs to string them up in the sun and air for a few days, then to hang them up in their huts, so that they may have the full benefit of the smoke, which serves to keep them entirely dry, and likewise preserves the seed from the attacks of insects, so that they may be thus kept perfectly good for a series of years, if necessary. I like this plan so much that I adopted it in all its integrity, and can honestly recommend it to others.*

THE PLANT: ITS PRODUCTION AND ITS VALUE.

It will seem, from what I have already said, that the canes of the imphee are much smaller and much lighter than the stalks of the real sugar cane; but at the same time, it must be remembered that the foliage is not nearly so large nor so dense as that of the sugar cane; consequently, the plants can stand very much closer together on the land, and thus make up in number for their smaller weight individually.

Thus, on an acre, if we have only 14,000 roots or stools, each stool will produce from five to twenty canes, varying in weight from a quarter of a pound to 1½

* It is worthy of remark that the natives of Upper Egypt call the sorghums *Baalee* or *Doura*; whereas, the Zulu-Kaffir name for the same plant is *Mabaalee*, the *ma* being simply a prefix which they give to a great number of their proper names.

pounds, each affording, on a low average, therefore, we will say, 84,000 canes, weighing 65,000 pounds, capable of yielding seventy-five per cent. of juice ; but if taken at only seventy per cent., then giving 44,100 pounds of juice, containing fifteen per cent. of sugar.

If from this quantity of juice the manufacturer cannot manage to produce two tons of good, dry, fair-colored sugar, then he must be unskillful indeed.

One English acre of imphee, grown under favorable circumstances, will yield fully two tons of dry sugar, and even more ; but I will not estimate the average return at more than $1\frac{1}{2}$ tons of fair, dry sugar, per acre, which it should most undoubtedly produce as an average crop.

For the information of those planters who are compelled to use their cane trash or bagasse, I may say that the trash of the imphee can be used precisely in the same manner, although its proper use really is as a manure to return to the soil.

The leaves and long tops of the plants form excellent food for horned cattle, horses, mules, sheep, etc., being much more delicate than the coarse leaves of the sugar cane.

If the plants are suffered to mature their seed, an acre of land would furnish a large quantity of grain, which may be used merely as grain for feeding animals and poultry, or in the form of flour, of excellent quality, as food for mankind.

I consider twenty bushels of this grain per acre a very low average crop, but it is by no means an item to be overlooked in calculating the value of the plant to Europe and to the world generally.

Having shown the value of one crop of imphee, perhaps it would be well to repeat that this one crop of imphee is off the ground in from three to four months from the day the seed was planted; and that, as this comes off, another crop is immediately springing up from the same roots, (if the weather will permit), to be ready in another three months; and even a third crop will be produced, provided the weather is warm enough.

We must now compare the imphee with its European rival, the beet root, which is at present so largely grown for its sugar.

I find that there is now manufactured throughout the whole continent of Europe about 160,000 tons of beet-root sugar, obtained from about 400,000 English acres of land, forming an average of something like eight hundredweight of good sugar per English acre.

Besides the sugar obtained from the beet root, we must take into consideration its other products, such as potash and alcohol, yielded by its molasses, and the quantity of food for cattle, furnished by its leaves and by its refuse pulp.

France alone has now three hundred and thirty-two manufactories of beet-root sugar, producing this year about 75,000,000 kilogrammes, (rather more than 158,300,000 pounds English) of syrup, besides molasses. M. Du Brontfaut declares, that by a certain process of his own, there may be obtained from this molasses (after the alcohol has been taken from it by distillation) a quantity of potash equal in weight to one sixth of the sugar produced from the beet root.

It is, however, quite evident that this quantity of pot-

ash can only exist in these roots by reason of the excess of saline matter in the soil whereon they are grown. In the great majority of cases this injurious excess of saline substance arises from the quantity of manure administered to the soil, with a view of obtaining a very large and heavy crop of beets—a result certainly realized, but at a great sacrifice of saccharine matter in the beets.

Viewing all these products, however, in the most favorable light possible, still no reasonable being can maintain for one moment that the produce obtainable from one acre of beet root is any way equal to that derivable from an acre of imphee, namely $1\frac{1}{2}$ tons of fair sugar, and its proportionate quantity of molasses, equal in every respect to the cane sugar molasses.

The next point of comparison is the expense of cultivation and manufacture; and I am firmly convinced that these are entirely in favor of the imphee, for, at the present moment, the practice is almost universal on the continent of sowing the seed, in the first instance, in a seed bed, or nursery, from which they are afterwards drawn and planted out in the fields. I do not say that this common practice is imperative, nor do I object to it on the score of economy or any other grounds, but I merely state that such is the usual custom. The period from sowing the seed to harvesting the beets, varies, according to my information, from seven to eight months, a space of time just double that required for the perfect maturity of the imphee.

This prolonged period naturally requires a corresponding addition of labor in the cultivation over and above that demanded by the latter.

But in the manufacture of the two a still greater difference exists in favor of the imphee. The beets have to undergo a careful washing, and have their crowns and roots cut off before they are fit for the manufacturer's operations; then they are either rasped by machinery into a complete pulp, which is afterwards put into a canvas cloth and subjected to the action of a hydraulic or other press, to get out all the juice; or they are cut into very thin slices, and these are treated by sundry peculiar processes, in order to obtain the sugar they contain in as pure a state as possible. The saccharine liquor, or expressed juice from the canvas bags, is next chemically treated to effect its defecation, and is afterwards evaporated to a certain density, run through animal charcoal filters, and finally concentrated, but only to undergo a further refining, or perhaps double-refining, as the raw beet root sugar (such as we may call beet root muscovado) is unfit for general purposes, and therefore cannot be used for common consumption as sugar-cane muscovado sugars are.

There are certainly many other highly scientific modes of obtaining the sugar from beets, among which the elegant chemical process (at present only partially applied) of Du Bronfaut is deserving of all honor; but I confine my remarks especially to those best known and so generally used on the continent.

The manufacture of imphee is, on the other hand, extremely simple; and the sugar produced, whether muscovado or white, is not distinguishable, even by the best judges, from the cane sugar of similar qualities; while the expense of manufacture is much less than that of beet root.

The main result of this comparison, apart from expenses for cultivation and manufacture, may then be stated :

Imphee.—Time of growth, three to four months ; sugar, per acre, thirty cwts. ; molasses equal to cane molasses.

Beet root.—Time of growth, seven to eight months ; sugar, per acre, ten cwts. ; molasses very inferior.

This, too, is on the broad supposition that the value of the molasses, fodder, etc., of the one, equals that of the other. I venture to say that the comparative value is so entirely in favor of the former, that beet root culture will gradually be relinquished until it becomes at length totally neglected.

We next turn to the sugar cane as its great rival ; and I dare say I shall be considered very bold in venturing a comparison, but facts are stubborn things, and no really sensible man will come to a decision until he has carefully weighed the evidence on both sides.

The sugar cane is a plant too well known to need any description here ; but there are some peculiarities in regard to it which must be recited, although they are actual truisms :

1. It takes, according to circumstances, from twelve to sixteen, to eighteen or to twenty months, from the crop being planted to its ripening.

2. Some very soft, juicy canes, do really contain, chemically speaking, only about ten per cent. of woody fiber ; but an overwhelming majority of sugar canes do most certainly contain, practically, a much greater proportion, some even as much as thirty per cent. !

3. Fine, average cane juice contains eighteen per cent. of sugar, not more.

4. A good average crop of sugar canes will weigh from twenty-five to thirty tons per acre.

5. Canes are apt to degenerate so fast, that constant recourse is had to the expedient of exchanging plant tops between estates very distant from each other.

6. The cane ratoons in twelve months, generally, from the time of cutting; and each time it ratoons the canes are less juicy, and contain a greater amount of woody fiber in proportion.

These points must be well considered:

1. During the eighteen months' growth what casualties may not occur to destroy, or, at least, very much injure, the crop: storms, severe drouth, fire, and lastly, white ants! And what sugar planter knows not the dire extent of these liabilities?

2. The large proportion of woody fiber contained in ratoons, and even in plant canes, naturally reduces very much the per centage of juice; but all ratoons do not so abound in woody fiber.

3. So alarming was the degeneracy of the sugar cane in Jamaica, that its Royal Agricultural Society and the Society of Arts in London sought all over the world for sugar cane seed, in the hopes of remedying this threatening evil.

Now, on the other hand, let us look at the imphee in respect to those identical points.

1. It takes, as I have already said, from three months to four and a half months, according to the kind planted,

from the time of sowing the seed until it arrives at maturity; and it will ratoon twice or three times afterwards, at intervals of three months between each cutting, provided, of course, that the warm weather permits their continued ratooning.

2. It is much more juicy than the generality of sugar canes, and contains far less woody fiber, which does not materially increase in the ratoons.

3. Fine, average imphee juice, contains fifteen per cent. of sugar.

4. A good average crop of imphee stalks or canes will weigh twenty-five tons per acre.

5. Imphee is produced from the seed; therefore, no deterioration can occur, as in the sugar cane; and the seed may be sown by means of a drill.

6. It will yield a crop of ratoons six to seven months from the time of the seed being first sown, being, therefore, two crops in that space of time; and will continue ratooning, if the seasons are favorable.

All these points I have abundantly proved to be correct; and, when they are acknowledged by the world at large to be really true, what, may I ask, will become of the sugar cane?

What tropical planter will eventually refuse to lessen his field risks arising from the casualties I have named, and simplify his cultivation, knowing, at the same time, that his crops come to bear a money value in the market in the short space of three to four months?

I venture to think that he will, of necessity, be compelled to adopt the imphee and discard the sugar cane, as a mere matter of self preservation; for, although in

Europe we can, perhaps, obtain only one crop from the land each year, yet the cheap modes of cultivation and the skillful manufacture which will be brought to bear upon it, will be quite sufficient to run the sugar planter off his legs.

From Canada to New Orleans, in America, we have a magnificent range for the growth of the imphee; and in the southern states two crops a year will be obtained, in lieu of the one miserable crop of cane sugar now realized.

I think that even these extremely brief remarks will be sufficient, for the present, to show the comparative value of the imphee, sugar cane, and beet root for sugar making.

APPENDIX.

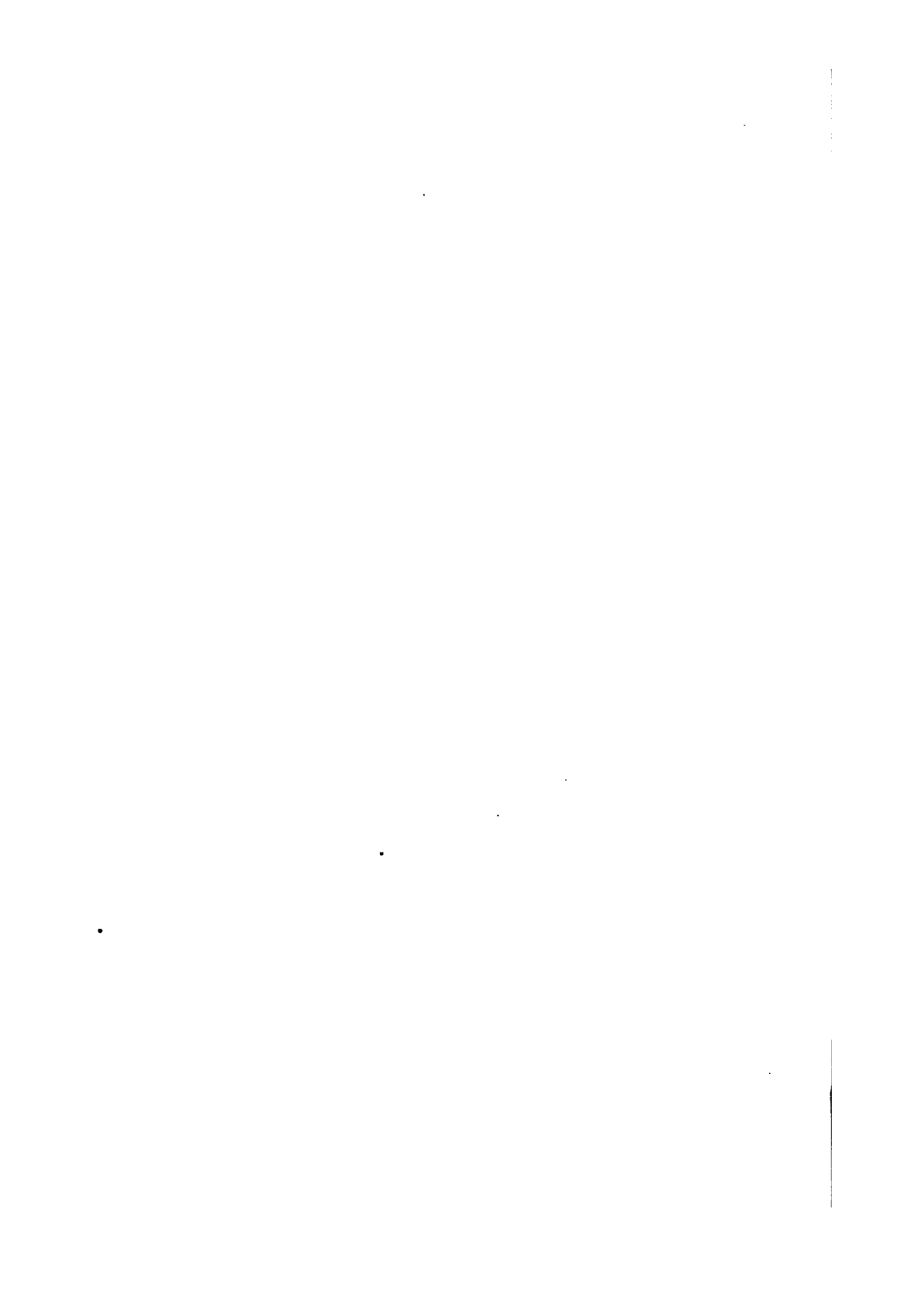

APPENDIX.

IN the following appendix will be found a number of papers which, by reference to the table of contents, on the preceding page, will be seen to be of much value, coming as they do from some of the most distinguished American and French investigators.

The very interesting work of Doctor Adrien Sicard, of Marseilles, has been so embodied in the foregoing pages that it has seemed to me useless to occupy space in furnishing a complete translation of its contents. I have contented myself by giving a most valuable chapter, embracing his minute and philosophical studies into the intimate composition of the stalk of the Chinese Sugar Cane, which will commend itself to the attention of every intelligent reader.

The French weights and measures of kilogrammes, hectares, metres, litres, &c., have been reduced into the American weights and measures, so as to be readily understood by all.

CORRESPONDENCE.

Copy.]

LEGATION OF THE UNITED STATES,
PARIS, May 13, 1857.

GENTLEMEN,—Your esteemed favor of the 28th March last was received and submitted to M. Alexandre Vattemare, the indefatigable friend of international exchange, especially with our country.

He has addressed to me a letter, and placed in my hands eight
[231]

pamphlets, which I send you. I hope that you will find that they contain all the information which you desire. I cannot add to it. With best wishes for your complete success in your laudable efforts to introduce into the United States a plant which will add to the valuable products of the country,

I am very respectfully,

Your obedient servant,

J. Y. MASON.

Messrs. HEDGES, MOCKBEE & Co., Philadelphia.

Copy.]

PARIS, April 20, 1857.

His Excellency JOHN Y. MASON, United States Minister.

DEAR SIR,—Immediately on the receipt of your favor, containing inquiries relative to the sorgho sugar plant, and the possibility of crystallizing its sugar, I called on the gentlemen here who could give me the best information upon this important subject. I enclose copy of a letter I received last night from M. Louis Vilmorin, one of the most learned (theoretically and practically) agriculturists of Europe, who has made a particular study of the sorgho plant, and is the best authority, I think, upon which we may rely.

To his letter, M. Vilmorin has added the accompanying eight pamphlets relative to the cultivation and extraction of alcohol, sugar, etc., which were published at Paris, Marseilles, Toulon, and also at Constantine, in Algiers, in 1855, 1856, and 1857. I trust that these will answer your purpose. Should you want further explanations, I will be most happy to procure them for you; yet I think that these will be sufficient to prove that *sorgho sugar can be crystallized*, and that the sorgho in its other products also is destined to render immense services to mankind.

Placing myself at your disposal for any information tending to the spread of useful knowledge and international courtesy,

I have the honour to be your Excellency's

Very humble and obd't serv't,

ALEXANDRE VATTEMARE.

Translation.]

PARIS, April 20, 1857.

To M. ALEXANDRE VATEMARE.

SIR,—The crystallization of the sugar of the sorghum, it seems, should be easily obtained in all cases where the cane can be sufficiently ripened; and as the *proportion* of the sugar is an unfailing index of ripeness, it follows that we could always be sure of obtaining a good crystallization of juices whose density exceeds 1·075, while weaker ones would not yield satisfactory results after concentration. I attribute this peculiarity to the fact that the sugar is preceded in the juice by a gummy principle, which seems to be transformed at a late date, for its proportion diminishes in exact correspondence with the increase of the sugar. The uncrystallizable sugar, or *glucose*, undergoes the same changes; that is to say, it is more abundant before than after the complete maturity, but its action seems less prejudicial to the progress of crystallization. The gummy principle obstructs it in two ways; for, beside being a serious obstacle to the commencement of crystallization, it afterwards renders it almost a matter of impossibility to purge the crystals if obtained. However, as I observed, this difficulty only presents itself in the employ of unripe canes; for, as soon as the juices acquire a density of 1·080 and more, they contain but little else than crystallizable sugar, and their treatment presents no difficulty. The lime employed, even to a slight excess, is not detrimental, it seems to me, in practice, as theory would perhaps indicate. Perhaps a slight fermentation, which is inevitable, may disengage enough carbonic acid to destroy the uncrystallizable compound formed by its union with the sugar. The fact is, that the best crystallizations obtained have been had in those experiments in which I feared to have used too much lime. I should remark that heretofore my operations have been but on a small scale, and it is necessary to be very prudent before applying the experiments of the laboratory to practical operations; but at all events, it seems to me, after all these trials, that the crystallization *will not meet with serious obstacles wherever the plant attains a complete maturity.*

(Signed)

VILMORIN.

CRYSTALLIZATION OF THE JUICE OF THE
SORGHO SUCRE.

BY D. JAY BROWNE.

THE sugar of commerce, it is well known, is a crystalline substance principally obtained by evaporating the juice of a gigantic grass (gramen) called "Sugar-cane," which is extensively cultivated for this purpose in regions within and adjacent to the tropics, where the climate admits of advantageous cultivation to the plant; although sugar, nearly identical in character, is manufactured in considerable abundance from the beet-root and maple, in countries of the northern temperate zone; and there is a fair prospect of success in producing an article of equal, if not superior quality, in the same regions, from another gramineous plant, the Sorgho sucré, already introduced. As doubts have been entertained by some as to the susceptibility of crystallizing the latter, the following facts and principles are presented, not only to throw light upon the subject, but to dispel the skepticism of those who are thus willfully or ignorantly groping in the dark.

The manufacture of sugar from the sorgho, as well as from the tropical cane, is beset with difficulties arising not only from the extreme liability and rapid change of the juice from exposure to the atmosphere, as it runs from the crushing mill, but often from the unripe state of the plant itself. Hence, in order to insure success, it is necessary that the process be conducted under certain conditions of temperature, modes of neutralizing the free acids contained in the juice, and the removal of the albuminous matter previous to evaporation and crystallization.

A fresh, thin, transverse section of ripe cane is diaphanous, resembling a similar slice of an apple or turnip, when seen by the naked eye. Under the microscope, it exhibits a cellular structure, the cells containing a transparent fluid, but presenting no appearance of crystals nor opaque matter. If the slice be dried, it becomes altered in its appearance, being no longer homogenous, as seen through a common magnifying glass or with the unaided eye; little dots of opaque, whitish matter are visible, protruding, apparently, from the

divided longitudinal tubes and transparent cells, as seen surrounding these opaque dots, in which, when placed in sunshine, glittering crystals are observable, which it may be inferred are sugar, formed in consequence of the evaporation of the aqueous part of the juice of the cells. These facts would seem to prove that the saccharine matter of the cane exists in it, in a state of solution, according to the commonly received opinion.

In the manner in which cane juice is usually obtained by the pressure of rollers, it consists of a compound, not only of what it holds in solution, but whatever it contains in suspension. However carefully expressed, it is never at this time transparent, but colored and turbid, in a slight degree. If viewed under a microscope of high power, innumerable granules will be seen floating in the fluid, varying in diameter from $\cdot 00010$ to $\cdot 00015$ of an inch. By careful filtration through bibulous paper, most of these granules will be separated, and the liquid will be rendered nearly transparent. The matter of which they chiefly consist, it is believed, is of the nature of gluten, and has the power of exciting fermentation, even if kept a year. It is a question not fully determined whether this glutinous matter exists suspended in the juice, when contained in the cells; whether it is separated from the walls of the cells, or is produced by the minute fragments of the longitudinal tubes of the cane, by the pressure employed. It may here be remarked that, besides gluten, there may be other proximate principles suspended in fresh cane-juice, such as starch, gum, wax, &c.; but their presence, in the minute quantities in which they occur, is probably of little importance in practice.

As to the question whether the saccharine matter contained in cane juice is altogether susceptible of being crystallized into sugar, or in part consists of other varieties of sugar, which are not crystallizable, or only so with difficulty, it may be stated that various opinions have been expressed by chemists in this respect. M. Hervey, of France, contends that there is no uncrystallizable sugar in pre-existence in the cane, and that the formation of glucose (grape sugar) or molasses is only owing to the action of the salts contained in the liquid during the manufacturing process. Be this as it may, it is

certain that the greater portion of the saccharine matter of the juice is crystallizable, and may be obtained in the state of crystals, if, after rapid boiling and filtering, the clear fluid be quickly evaporated, the latter operation being a condition of absolute necessity in sugar making, as, by slow boiling, at a temperature of 212°, or even exposure for a considerable time to a temperature below the boiling point, glucose may be formed from the purest crystallized sugar dissolved in water. On the contrary, if the concentrated solution of sugar be heated beyond 230° F., it undergoes alteration, and is changed, at least in part, into uncrystallizable sugar, or saccharine mucilage. When we consider how nearly allied these varieties of sugar are, and likewise how nearly allied in their composition they are to other substances, such as gum, starch, woody fiber, &c., we cannot be surprised either at the conversion of one kind of sugar into another, or into these substances, or at the formation of sugar from them. The above-named substances are chemically *isomeric*; that is, nearly identical in composition, so far as their elements are concerned, and the proportions of these elements, though the substances, gum and sugar, are so different in their properties. These reflections may be applied with as much force to the results obtained in the elementary analysis of various kinds of sugar, presented in the following table:

	Carbon.	Oxygen.	Hydrogen.	
Cane sugar, . . .	{ 42·47	50·63	6·90	Gay-Lussac and Thenard.
	{ 42·22	51·17	6·60	Berzelius.*
	{ 42·85	50·71	6·44	Prout.
Grapesug.(glucose),	36·71	56·51	6·78	Saussure.
Sugar of starch, .	{ 37·29	55·87	6·84	do.
	{ 36·20	56·75	7·05	Prout.
Sugar of honey, .	36·36	56·58	7·06	do.
	{ 38·53	54·60	6·87	Saussure.
Sugar of manna, .	{ 38·70	54·50	6·80	Prout.
	{ 44·10	49·76	6·13	Henry and Plisson
Glycerin,	40·08	51·00	8·92	Chevreul.
	{ 38·82	53·83	7·24	Gay-Lussac and Thenard.
Sugar of milk, . .	{ 45·26	48·34	6·38	Berzelius.
	{ 40·00	53·36	6·63	Prout.

* The first analysis published by Berzelius differs considerably from this, being carbon, 44·2; oxygen, 40·01; hydrogen, 6·78; Berthelot and Saussure obtained results corresponding with those of Guy-Lussac.

In comparing these numbers, it will be seen that cane sugar, which can be considered as the prototype, may be represented chemically by an atom of carbon and an atom of water; and that the proportion of water increases as the sugar becomes less capable of compact crystallization. Accordingly, the sugar of grapes, of starch, of honey, &c., has less carbon and more water than cane sugar. The results of the different analyses are also the more discordant as the sugar is less regularly crystallizable and associated with a greater number of foreign substances, as in the sugar of manna and the sugar of milk. And the analysis which exhibits the greatest proportion of hydrogen is precisely that of the sweet matter, (glycerin,) which is procured from the most highly hydrogenated of all these substances, namely, oil and fatty matters.

Although the principles of sugar making are simple, the practice, as before stated, is beset with difficulties and attended with loss and injury of material, arising from the extreme susceptibility to change of the cane juice itself. The latter, as it runs from the crushing mill, is nearly colorless; but a very brief exposure to the atmosphere, in warm weather, hastens decomposition, which, unless checked, rapidly advances, and in a short time converts this sweet-tasted, bland liquid into a spiritous or acescent product, turbid from insoluble suspended matter, and wholly unfit for the purpose to which it was intended to be applied. To guard against this evil, the operator always endeavors to conduct the first part of the process, at least, as expeditiously as possible. But instead of heating the freshly expressed juice of the sorgho, in order to insure its crystallization, in a large vessel to blood-heat, or upward, and adding a little slaked lime, as is usually the case, to neutralize the free acids, which are always present in the juice of the sugar cane, the lime should be applied while the liquid is cold, conformably to the method discovered by Leonard Wray, of London, and recently patented by him in Europe and elsewhere. The lime is employed for the purpose of saturating these acids, which should be done as quickly as possible, in order to restore the gluten contained in the liquid to its original insolubility, so that it may immediately coagulate, and, in this manner, envelope in its volume all those substances consisting of green and gummy matters. Let it be borne in mind, in

connection with this process, that the lime will absorb a greater quantity of free acid, and this more rapidly, in a cold than in a warm state, in a similar manner as cold water will dissolve more lime than warm. After this proceeding, the liquid is strained through cloths, and then clarified with nut-galls, or other tannic substances, aided by the action of heat, when it is again strained or filtered, and then boiled down to a proper consistency for granulation, conformably to the method patented by Mr. Wray.

In a letter from M. Louis Vilmorin, of Paris, bearing date of April 20, 1857, he says: "The crystallization of the sugar of the sorgho, it seems, should be easily obtained in all cases where the cane can be sufficiently ripened; and, as the proportion of the sugar is an unfailing index of ripeness, it follows that we could always be sure of obtaining a good crystallization of juices the density of which exceeds 1.075, whilst weaker ones could not yield satisfactory results after concentration.

"I attribute this peculiarity to the fact that the sugar is preceded in the juice by a gummy principle, which seems to be transformed, at a later date, for its proportion diminishes in exact correspondence with the increase of the saccharine matter.

"The uncrystallizable sugar, or glucose, undergoes the same change; that is to say, it is more abundant before than after the complete maturity; but its action seems less unfavorable to the progress of crystallization. The gummy principle obstructs it in two ways; for, besides being a serious obstacle to the commencement of crystallization, it afterward renders it almost a matter of impossibility to purge the crystals, if obtained.

"However, as I observed, this difficulty only presents itself in the employment of unripe canes; for, as soon as the juices attain the density of 1.080 and more, they contain but little else than crystallizable sugar, and their treatment presents no difficulty.

"The lime employed, even to a slight excess, is not so detrimental, it seems to me, in practice, as theory would perhaps indicate. Perhaps a slight fermentation, which is inevitable, may disengage enough carbonic acid to destroy the uncrystallizable compound formed by its union with the sugar. The fact is, that the best crystallizations

obtained have occurred in those experiments in which I feared to have used too much lime."

Subjoined is an extract of another letter from M. Madinier, of Paris, on the same subject :

"Up to the present time, the making of sugar from the sorgho has received but little attention, in France, owing to the present state of commerce, which makes it much more advantageous to convert the cane into alcohol than into sugar. Aside from this fact, it is certain, that from this plant crystallizable sugar can be extracted similar in every respect to that made from the cane of the tropics. Of this, I entertain the highest conviction, which is supported by authentic, though not very numerous, facts. * * * * * The stalks of the sorgho contain crystallizable sugar, without furnishing a greater quantity of molasses than the cane. An experiment made at Verrières, with Clerget's apparatus, showed the juice to contain 16 per cent. of sugar, of which there are only 10½ per cent. crystallizable, and 5½ per cent. uncrystallizable ; yet we can by no means depend upon a result gained from plants grown in the Department of the Seine and Oise, in a climate altogether beyond the range adapted to the sorgho."

Thus it will be seen that the making of sugar has been much aided by science. It was a philosophical chemist who first introduced the vacuum-pan method into use, by which such facility was given, with a remarkable reduction of the price of the article, to the refining of sugar. It has been by the application of chemical science in France that the sugar from the beet root, the produce of that country, has been able to compete with cane sugar, affording a remarkable instance of the conquest, and it may be said, the triumph, effected by science, as the proportion of saccharine juice of that root is only about half as much as that of the cane, and is mixed with substances more difficult of separation, and more injurious in their reaction. Let the same skill, directed by science, be applied to the making of sugar from the Sorgho sucré, and we may reasonably expect the happiest results.

CHEMICAL RESEARCHES ON THE SORGHO SUCRE.

BY C. T. JACKSON, M. D., OF BOSTON, MASSACHUSETTS.

On the 29th of October, 1856, I received from the Patent Office a bottle of expressed juice of the *Sorghum saccharatum*, procured from plants raised upon the government grounds in Washington. This juice, after being strained through fine linen, had a specific gravity of 1.062; and, after boiling and the separation of an albuminous scum, 1.055. Three and a half fluid ounces of the strained juice, evaporated at 212° F., until it became a dense straw-yellow syrup, too thick to run, when cold gave 217 grains of saccharine matter. That portion of the juice which had been freed from albuminous matter and filtered through paper, gave, on evaporation of a fluid ounce, 78 grains of thick yellow syrup, which, being dissolved in absolute alcohol, left 9 per cent. of mucilaginous substances containing starch. The alcohol took up 69 grains of saccharine matter. This is equal to 14.36 per cent. on the juice.

Other portions of the juice were operated upon by lime water and bone black, and filtered and evaporated to syrup. A small proportion of crystallized sugar was obtained from the bottom of the vessel, in which the syrup had stood for some days. A part of the juice, diluted with warm water, with the addition of a little yeast, fermented and produced spirit, which, on being separated by distillation, was found to be an agreeably flavored alcohol, having, as M. Vilmorin has stated, a slight noyau taste. Good judges declared that it would make excellent brandy spirit. According to the experiments of Vilmorin, the amount of absolute alcohol obtained from the juice is a fraction over 6 per cent.

On the 3d of November I also received from the Patent Office two parcels of the sorghum plant, in different stages of ripeness. That with quite ripe seeds was by far the sweetest; while the green one, which was just in flower, contained but very little saccharine matter. One thousand grains, taken from the middle of the ripe stalk, when peeled, gave 670 grains of pith, from which the juice was separated.

The latter, on being evaporated to a thick syrup, gave 90 grains of saccharine matter, or 9 per cent. on the weight of the stalk. Another sample gave from 2½ ounces of the pith, 217 grains of thick syrup, or 12 per cent. Thus we have from 180 to 240 pounds of saccharine matter, in the form of a dense syrup, to a ton (2,000 pounds) of the stalks. By means of a screw press, I separated the juice from some of the canes, which had a specific gravity of 1.0987.

Being desirous of ascertaining the saccharine value of the sorghum raised in Massachusetts, I obtained from Capt. R. A. Wainwright, of the United States Arsenal, at Watertown, in this state, five plants, which had been cultivated on the arsenal grounds. Sixteen ounces of one of these plants, nearly ripe, gave 9½ ounces of clear pith, which I exhausted of its saccharine matter by means of boiling, distilled water, and pressure. This liquid, on evaporation, gave 742 grains of thick syrup, too dense to pour from the vessel when cold. The yield of saccharine matter in this case was 10¾ per cent.

Another and riper sample, from the same parcel, yielded from 1,000 grains of the stalk 640 grains of pith, and 146 grains of thick syrup, or 14¾ per cent. of saccharine matter. On expression, the plant yielded a clear, sweet juice, having a specific gravity of 1.0975.

Analysis of the Bagasse.—One hundred grains, dried at 212° F. and burned in a platinum vessel, left 1¾ per cent. of gray ashes. Having thus determined the proportion of inorganic matter in the bagasse, I burned a larger quantity for further experiment. It was found that the ash consisted of the following ingredients :

	Per cent.
Silicic acid - - - - -	14.40
Phosphoric acid - - - - -	13.42
Sulphuric acid - - - - -	28.70
Chlorine - - - - -	3.70
Potash - - - - -	8.10
Soda - - - - -	9.60
Lime - - - - -	11.80
Magnesia - - - - -	9.80
Traces of oxyd of iron, a little carbonic acid, and loss	0.68
	100.00

This analysis shows that gypsum (sulphate of lime) will operate favorably as a fertilizer on this plant; and it is evident that the bagasse ashes would serve as a good manure for the crop.

THE CRYSTALLIZED SUGAR QUESTION.

My readers will perhaps remember, that in the chapter on Soils and Manures, the proposition was distinctly laid down, that in cases where the sorgho had been grown on soils containing large proportions of soluble saline matters, or when manures of a nitrogenized nature had been applied to the plant, the juices were rendered averse to crystallization, but were not deteriorated, so far as the production of alcohol or syrup is concerned. I mention these facts in this connection, as, perhaps, affording some light upon the vexed question as to whether or no the sorgho juice will give perfect crystals of cane sugar, and as prefatory to the conflicting opinions of Doctors Hayes and Jackson, both gentlemen of the highest acknowledged ability as chemists, and one of them, at least, practically acquainted with sugar making.

I have the highest respect for the professional position of Dr. Hayes, and esteem him as a private gentleman, but cannot print his very able paper without expressing the hope that future experience may prove that the canes and syrup upon which his experiments were undertaken were raised under the unfavorable application of manures containing much nitrogen, or on soils of the character above indicated; and, from personal communication with that gentleman, I know he would rejoice as much as any one if success shall prove my supposition to have been a just one.

From the "New Orleans Bee" we have most unequivocal testimony as to the actual presentation to the editors of crystallized sugar made by Prof. Azequin; and as corroborative of that fact, I append the following extract from the official report of the meeting of the *Comice Agricole of Toulon*, held December 5th, 1854:

"The honorable President presented to the Assembly a detailed report upon the Culture of the Sorgho, its Uses and Products. This report, of a very high degree of interest, will be inserted in the follow-

ing number of the Report of the Assembly. M. DE BEAUREGARD (the President) PRESENTED TO THE ASSEMBLY RUM AND CRYSTALLIZED SUGAR EXTRACTED FROM THE SORGHO. "A. PELLICOT."

The report of the Count made its appearance according to the above announcement, and the Count speaks as follows :

"I have likewise been able, gentlemen, (thanks to the obliging and intelligent assistance of M. Verignon, a chemist at Hyères,) to make attempts to obtain the crystallization of the syrup from the juice of the *holcus saccharatus*. . . . After practical boiling, losing the hope of seeing in form the crystals, we left upon a shelf the concentrated syrup without disturbance for a while, and we have been most agreeably surprised to find, on again looking at it, that *the entire inside surface of the vessel containing it was studded with very beautiful crystals*, which I have the pleasure of exhibiting before you to-day."

At the sitting of May 1st, 1855, was presented a paper, entitled, "Documents Nouveaux sur la Culture du Sorgho à Sucré," in which occurs the following :

"We have recently learned from a manufacturer at Lyons, M. Doney, that he has, the past year, obtained from a small quantity of sorgho stalks, treated by him, beautiful cubic crystals of sugar. His process is as follows : The clippings of sorgho stalks are submitted to maceration ; then they are pressed, and the juice obtained is reduced by boiling. Treated by lime which is purified of salts, defecated by means of ox blood, clarified with animal black, the juice evaporated gave BEAUTIFUL CRYSTALS OF CANE SUGAR."

Testimony stronger than this could not be made. In his official report to the Minister of War, Dr. Turrel distinctly states, that experiments made by a Commission of the Imperial Acclimation Society had "resulted in their obtaining magnificent cubic crystals of sugar."

Thus supported, then, my readers will, doubtless, unite with me in the previously expressed wish, that indeed by the 1st of January we may be able to offer a complete refutation to the opinion advanced by Dr. Hayes. It must be remembered that, in making beet-sugar, the manufacturer is sometimes obliged to wait as long as a fortnight before the syrup will strike into crystals.

Doubtful as has been the question as to the crystallization of the

sorgho juice, the paper of Mr. Wray entirely sets at rest any doubt as to the possibility of sugar making with the imphee juice; and if the former be found wanting in this season's trials, the effect will be, to augment the demand for the imphee, and largely extend its culture.

ON THE SACCHARINE MATTER FOUND IN THE VARIETY OF SORGHUM, CULTIVATED IN NEW ENGLAND AS A SOURCE OF SUGAR.

By AUGUSTUS A. HAYES, M. D., Assayer to the State of Massachusetts.

EARLY after the ripening of this plant the stalks were sent to me for a chemical examination of the kind of sugar produced from the juice. Samples of the syrup, from several places in the northern states, and one sample made by Colonel Peters, of Georgia, were also given to me.

The research was deemed important in its economical bearings, and interesting in a chemical view. The course was, therefore, made to embrace a knowledge of the sugar as it naturally existed in the stalk, in its appropriate cells, and of the sugar extracted by the refined methods of modern chemistry.

Sugar in the Cells.—The horizontal and angular sections of the pith of various samples of the sorghum plant, produced from the black, or French variety of seed, were found, when viewed by the microscope, to show perfectly-formed cells, with every character of maturation.

In these cells, isolated from other principles, a fluid sugar could be seen and experimented on easily.

When withdrawn from the cells it did not crystallize, even after long exposure. Recent pith, carefully dried by absorbents, did not exhibit any crystallized sugar. Slips of the common sugar cane, under the same exposure, showed crystals of sugar formed, and, as it dried, brilliant, colorless, and beautiful groups formed in the cells, without the apparent presence of any other matter. A minute drop of the fluid in the cells of the common sugar cane, soon after exposure, became a

mass of crystals; and no two secretions are more unlike than the fluid sugar of the sorghum and the crystallizable juice of the common sugar cane. The fluid sugar of the sorghum in the cells became brown when treated with potash. It did not become dark in sulphuric acid. It readily dissolved in alcohol, and left, by evaporation, a syrup; no crystals. A minute drop, when warmed, instantly reduced the tartrate of copper, dissolved in potash, to protoxide of copper. These are the characters of glucose; and so far as observation and tests can serve us, we must conclude that the saccharine matter in the cells of the sorghum plant is glucose, in the state of a syrup, without the presence of true sugar.

At this point of the examination I supplied Prof. John Bacon, of the Medical College, with samples of the stalk, who, with his usual accuracy and skill, after a minute examination, failed in detecting any cane sugar, and pronounced the matter to be glucose, as secreted by the plant.

Sugar Extracted.—The clean pith was bruised in contact with pure animal charcoal, and the saccharine part extracted by cold and pure alcohol, which was evaporated at the ordinary temperature of the air, and left a fluid, colorless, sweet glucose. This could be dried over sulphuric acid to a paste; but it attracted moisture from the air, and returned to the state of a syrup on exposure. It contained a trace of a lime salt, but was neutral. The animal charcoal was then boiled in successive portions of alcohol, and the solutions obtained afforded only the syrup of glucose; no crystallized sugar.

A quantity of the pith was crushed in mixture with some pure carbonate of lime, animal charcoal, and water, at the common temperature of the air. The colorless, neutral syrup, was rapidly withdrawn, and one portion evaporated, by the heat of steam, to a thick syrup, and closed from the air. It remained a syrup after fourteen days, and when spread thin on plates of glass, gave a few microscopical crystals of saline matter united to glucose. Another portion of the colorless, pure juice, was evaporated in a current of warm air; it dried to a thick varnish, without a trace of any crystals being seen. These are the characters of glucose, physically.

An analysis of a portion of the pure juice was made by reducing it to a nearly dry mass and treating it with alcohol saturated with

cane sugar, in which it dissolved, excepting a mere trace of a lime salt; proving that no true sugar exists in the juice, chemically.

Samples of Sorghum Sugar.—These, as specimens of the product obtained by boiling to the state of a dense syrup the expressed juice of the plant, were all impure; differing much, in this respect. They exhibited, after repose, some brilliant grains as a deposit. After separation, these grains proved to be in large part, transparent, minute fragments of pith cells mixed with some crystals, which, containing chlorine, sulphuric acid, lime, and alkaline base, were considered to be compounds of sugar and alkaline salts. The fluid sugar was, in every case, acid, and exhibited a strong tendency to ferment, after it had been a few hours mixed with water. It was, therefore, in every case subjected to the usual process of refining before the application of the tests was made. Neither of the samples, when subjected to the tests which have been named, exhibited any traces of true sugar; and the characters of solubility, and freedom from tendency to crystallize, place the fluid sugar obtained in the usual way, among the fruit sugars, as varieties of glucose.

After long exposure to air, the pure glucose, chemically obtained, forms mammillary concretions made up of radiating prisms, and then becomes the variety of glucose called dry fruit sugar: adding another distinctive character of fruit sugar.

I purposely excepted from my trials all unripe or decayed stalks. Some subsequent observations show that the unripe stalks afford much saline matter which mixes with the syrup.

When we consider the definiteness and reliability of the chemical tests for glucose, the clear and certain manner in which they distinguish all its varieties from ordinary sugar, we may conclude that, as far as physical and chemical means permit, the question in relation to the kind of secretion in the sorghum of the northern states is settled. This plant cannot, by any known process, be made to yield any other saccharine matter than glucose, and there is no method known to chemists by which glucose has been converted into sugar.

Generally, those persons skilled in the manufacture of sugar from the maple sap, who have failed in producing sugar from the sorghum, have attributed their want of success to a difference of composition in

the juice, as compared with maple sap. This is the true view, and reflects no discredit on the ability or judgment of those enterprising persons who have endeavored to add another to our resources of an agricultural kind. Some few persons have boldly asserted that they have obtained sugar from the sorghum of the northern states, and an impression has been fostered that some new process of manufacture would enable us to obtain a supply of sugar from this source. It is a part of the duty of men of science to point out what can be done, and thus direct attention to resources around us; it is no less a duty on their part to draw the broad line of distinction between what can and what cannot be accomplished. No dairy man or dairy woman would accept the proposition of converting at will butter into cheese, or cheese into butter; yet this may be done as easily as the glucose of the sorghum can be converted into sugar.

While the variety of sorghum produced from the French seed in our northern states contains in its cells only glucose, which can be easily separated and exhibited with all its properties, we have before us a positive fact: those who suppose sugar to exist in the plant are supporting a negative, until they present us that product in a tangible form.

16 *Boylston Street, Boston, April, 1857.*

LETTER FROM MR. WRAY TO THE AUTHOR.

CANADA, July 4th, 1857.

HENRY S. OLCOTT, Esq.

MY DEAR SIR,—In reply to your inquiry, I beg leave to make the following remarks upon the statements put forth in Boston by Doctors Hayes and Bacon, relative to the character of the sugar contained in the Chinese Sorgho, which is now so generally denominated the Chinese Sugar Cane.

That small quantities of crystallized sugar (identical in all respects to that of the sugar cane, and not grape sugar) have from time to time been produced in France, and even in this country (North America) is an established fact, admitting of no denial, and, as such, quite sufficient to prove that the Chinese Sorgho does, under certain

favorable conditions, contain, and will, by a peculiar mode of manufacture, yield a proportion of real cane sugar, however small that proportion may be.

The remarkable assertions of Messrs. Hayes and Bacon must, therefore, in my opinion, have arisen from two causes, of which those gentlemen were not aware, viz.,

1st. The sorgho stalks, or canes, which they examined were, in all probability, either unripe, or past the stage at which crystallizable sugar existed in their juice ; or, again, those canes might have been grown on such rich lands as did not permit of their juices being perfectly elaborated.

2d. The "very carefully prepared syrup of Col. R. Peters, of Georgia" had, in reality, been boiled down in the rudest manner, in a large iron cow-pot, after a constant exposure to a great heat for a period of from seven to eight hours.

It might be an interesting and highly instructive experiment to such chemists (and others who know nothing of sugar making) if they would try the effect of from seven to eight hours continuous boiling (or simmering) on a simple solution of pure lump sugar and water ; always remembering that a large iron cow-pot (hung in a very primitive manner) is the vessel to be employed. What do these gentlemen imagine would be the product resulting from the action of such a long continued heat on this simple solution of pure cane sugar ? What would be the proportion of crystallizable sugar remaining, and how much glucose would they have achieved ? I should like them to make this trial, and favor the public with a statement of their results.

I beg you, my dear, Sir, to believe that I do not for a moment call in question the ability and honest purpose of such well educated and respectable men as Doctors Hayes and Bacon ; but as a dabbler in chemistry, and as an old sugar planter, I well know how easily men of the highest order of intelligence may be deceived in such investigations, and may omit to make due allowance for unknown circumstances, which may, nevertheless, exercise an entire controlling influence on the result of their experiments.

So far, therefore, in answer to your inquiries respecting the Chinese Sorgho, which I hope may be satisfactory ; but in speaking of the

real "Imphee" of Kaffirland, which I have introduced to the notice of the world from south-eastern Africa, you must be good enough to understand that I draw a very marked distinction between them and the plants known under the name of Chinese Sorgho, in regard to their value as sugar producing plants.

The juice of the Zulu-Kaffir imphee is much more limpid, and much less mucilaginous than that of the Chinese sorgho; and is consequently very easily induced to crystallize.

The African plant, under ordinarily favorable circumstances, so perfectly elaborates its juice that I have generally found it to contain almost as large a proportion of cane sugar as that of the real sugar cane itself grown in the tropics.

The samples of sugar made from the imphee, and in your possession, have been pronounced to be equal to the best clayed Havanas; but, farther than this, I may tell you that I have submitted them to my honored and revered friend Justus Liebig, the great chemist of our age, and he has found them identical in all respects to the sugar from the West Indian and Javanese canes.

I do not think I need say more, for in a month hence I shall commence manufacturing my imphee crop, and I hope then to give you the fullest proofs that whatever the Chinese Sorgho may yield, my African Imphee will at least come up to the character it has earned, and yield sugar abundantly.

And I remain, my dear Sir,

Very faithfully yours,

LD. WRAY.

MONOGRAPH OF THE CHINESE SUGAR CANE,
CALLED THE SUGAR SORGHO.

BY DOCTOR ADRIEN SICARD,

Secretary of the Marseilles Horticultural Society, Member of the Imperial
Acclimation Society, etc., etc. Marseilles, 1856.

CHAPTER V.

Studies in the Structure and Intimate Composition of the Chinese
Sugar Cane.

LET us take a joint of the cane, deprived of the clasping part of the leaf, designated by the name *petiole* or footstalk, and let us study it from exterior to the interior.

Immediately beneath the footstalk we find a deposit of cerosie, which completely covers the epidermis of the cane. This deposit, which is but slightly apparent midway between the knots, under the footstalks is considerable enough, on the contrary, from its being protected from the contact with the air. Some canes will even manifest this same substance on their leaves. This is called *cerosie* because of its resemblance to wax (*cire*.)

The cerosie being passed, we come to the epidermis, or outside coat; this is thin, very strong, tinted usually with colors of straw color, yellow, apple green, and rose color, passing into a violet when the cane is too ripe. If a piece of this epidermis be magnified to five hundred diameters, it appears to the eye like the bark of the elm as seen in nature by the naked eye, especially if the examination be made on the portion covered with cerosie. If the fragment of epidermis be turned so as to present the interior face, there will be seen angular protuberances, which correspond with the joints of the cells, and filaments running in a direction from above to below, or from knot to knot, of the stalk. Whatever pains be taken to separate the epidermis of the cane, some fragments of cells will always be seen adherent.

I submitted the epidermis to the action of pure sulphuric acid* ;

* All my studies of organic chemistry with the view of discovering the intimate structure of the Chinese Sugar Cane have been made under the microscope.

it assumed in this liquid a deep yellowish color, and the appearance of the very rough bark of a tree, marked with black spots and streaks. By the addition of a drop of anhydrous alcohol, there was immediately formed, in the liquid, a movement of oscillation; the fragment of epidermis was borne by the current in the liquid from left to right. At the end of some minutes the yellow color had entirely disappeared, but the piece preserved the original appearance. Submitted, then, to the action of tincture of iodine, the epidermis preserved its transparency; except that the more deeply tinted parts assumed a very light blue color, surrounding plates and cells which were completely white. At a magnitude of one hundred diameters the objects of our previous study can be seen, but in this case the piece of epidermis looks like the bark of the plane tree.

It is difficult, at this magnitude, to recognize the details above mentioned; still with a great experience in microscopic study it may be done.

If the piece of epidermis belongs to a cane long time previously ripened, or the experiments be made with the knots nearest the ground, it will be found that the cerosie always will adhere to the epidermis, even though it may have been scraped to remove the former; the addition of sulphuric acid can determine the yellow color; but anhydrous spirit of wine subsequently added, does not produce so strong a sudden oscillatory movement as in the former experiment. The decoloration of the tissues does not take place; they always preserve the yellow color, and the disposition of the fibers is the same, except that the most prominent tubes are particularly distinct. The tincture of iodine added to the solution does not give any color changes, except that the deep color of the epidermis becomes clearer. Some fragments of cells are visible.

The epidermis is now removed. We next come to the dermis, or inner coating.* Submitted to a glass of five hundred diameters, it presents an assemblage of tubes all disposed side by side in manner according to the height of the plant. Submitted to the action of pure sulphuric acid, the deep color soon passes into a red brown; numerous

* This piece of derma was taken from the last joint of a cane of large size, and it had remained on the stalk after its ripening.

cells of rounded form show themselves under the tubes. The addition of anhydrous alcohol causes a very slight movement of oscillation ; the yellowish-red-brown color brightens up and becomes yellow ; but the longitudinal tubes are perfectly apparent, and upon these are seen at intervals rounded cells. These cells are unequal, and of three dimensions ; large, medium sized, and small. In the liquid are seen floating perfectly white crystals.

The addition of the tincture of iodine produces, in time, in certain portions of the tubes, a slightly violet hue ; but the little cells have become colored a deep violet. As to the crystals, of which we have previously spoken, they preserve all their whiteness.

Let us continue our researches. The epidermis and dermis have been removed. We next find between the knots long threads of a yellowish color, running from one knot to the other, and which may be easily removed by hand : they are united together by a kind of pith. A specimen of these threads was submitted to the microscope, (magnified to one hundred diameters,) and despite all my efforts, it was impossible to completely deprive it of its covering of pith. Under the glass the appearance it presented was that of a magnificent column of stalactite of the most beautiful whiteness. Sulphuric acid colors this part of the plant yellow on the edges, and reddish brown throughout the rest of its surface ; a continuance of about a quarter of an hour in the liquid produces the disaggregation of little grains almost white, but bordered with a more roseate hue.

The addition of anhydrous alcohol produces the complete decoloration of the portion formed by the separation of the small grains above mentioned ; they may be distinguished perfectly isolated from each other, and preserving by their arrangement the form of the bark of a tree, or, rather, of a lace of dazzling whiteness. As to the portion which has not been detached, it preserves its original form and color.

The addition of a strong proportion of tincture of iodine has not changed the color of the grains of which we have spoken ; only the liquid in which they are held, becomes strongly tinted yellow ; the surface seems to have assumed a slightly bluish tint. As to the cells, and the portion of the specimen which was not separated, they have taken on a bluish violet. Besides this, there is seen the yellow color in portions of the cell not changed to blue.

If we remove with great care, by means of a piece of silk paper,* the liquids in which we steeped the piece of sugar-cane used in our experiments, and if we replace it by water, suffering the piece of cane to steep for some minutes, we remark that the tissues become more transparent; but the violet color always remains in the thicker portions, especially in the cells. These have a hole in their center.

If we deprive of water † the specimen of Chinese Sugar Cane undergoing experiment, and replace this water by anhydrous alcohol, we observe a decoloration of the tissues and the separation of the portion which had formed the lace; this detaches itself from the piece, lets escape a large number of entirely colorless crystals, and ends by taking on the appearance of a hempen thread, which should be placed in the field of the microscope and examined at the magnitude which was employed by us at the commencement. We shall find, floating in the liquid, some violet cells, which have preserved their rounded form. As to the piece which did not dissolve, it maintains the appearance indicated in the preceding experiments.

Another piece of filament, taken from the same place, and submitted to the same magnifying power of five hundred diameters, has seemed to us organized; it represents a fragment of hemp, with the exception that the latter is white throughout the greater part of its length. Submitted to the action of pure sulphuric acid for about an hour, we observe the separation of the cells; the filaments take the appearance of threads of hemp seen by the naked eye, and placed beside each other we observe some disaggregated cells; the filaments have a black color.

No change caused by the addition of anhydrous alcohol. The tincture of iodine added to the mixture, makes to appear slight violet or bluish spots. The general tint is observed to be diminished in intensity. The entire liquid is sprinkled with white crystals.

The specimen which we are about to study is taken from the center of the cane. We were at pains to separate it entirely from the threads which we have just dissected; it presents to the naked eye the appear-

* It will readily be conceived that it is impossible to accomplish the entire removal of all foreign matter.

† We cannot say but that a little water has actually remained after all our precautions.

ance of elder pith, except that on pressure it permits to escape a very sweet juice.

Under the microscope, at a magnitude of one hundred diameters, the specimen which is the object of our study resembles a grain of sugar seen with the naked eye, and of which the appearance is of a brilliant whiteness; the crystallization is like that of the most beautiful sugar. We remark on the edges a whitish liquid which oozes from it; in it we see some small cells, which are doubtless those which have permitted to escape the liquid which we have just noticed.

Some moments' rest in pure sulphuric acid changes the appearance of the specimen which we study; the edges are yellow, the center represents a bunch of grapes, of which the grains are perfectly distinct, and of a violet red color; some grains separated from the bunch have an appearance identical to those which we have observed in the preceding experiments, except their violet red color; they are all perforated with a hole in the middle. Some crystals are seen in the liquid.

Anhydrous alcohol, added in the segment of sphere, produces a slight movement of oscillation from right to left; the violet red color is unaltered; the edges only have assumed a tint much less yellow, and which has a tendency to disappear. As to the crystals disseminated throughout the liquid, they are always incolorous.

The addition of the tincture of iodine gives, after a contact of some minutes, a color less deep; one would say that in place of coloring the substance, the iodine had, on the contrary, lightened it. However, by regarding it with the greatest attention, we distinguish little veins of an infinitesimal dimension, which appear colored violet.

The piece of Chinese Sugar Cane submitted to the above experiments, was now taken from the liquid, then placed in the segment of a sphere, with anhydrous alcohol that we had increased with water. A portion of the fragment was dissolved; at the bottom of the liquid we see a great quantity of white crystals. As to the mass itself, it is found at the bottom of the liquid, and presents the appearance of a mixture of empty cells, of crystals and granules, the whole seeming white by refraction, and tinted violet by reflection.

A fragment imperceptible to the naked eye, submitted to a magnitude of five hundred diameters, is completely identical with crystals of

sugar in the perfect state ; they are surrounded by an incolorous liquid. This fragment has stripes very light and blackish in color.

Pure sulphuric acid has entirely changed the appearance of the fragment which we are studying ; it has taken a blackish color in the surface of the crystals, which have become more deep.

Anhydrous alcohol, added to the mixture, seems to dissect the crystals.

An addition of tincture of iodine lessens the coloring. By refraction, the crystals are completely white.

We have taken at the center of a knot, a portion of the substance which it contains, seeking to separate, as much as possible, from it the filaments which, in this plant, run from the ground to the top of the stalk, bending, it must be remarked, at each knot. It is, so to speak, compressed, and in the experiments which I have made on these threads, they have always broken at this part.

The portion above mentioned was placed under the microscope. At a magnitude of one hundred diameters, it resembled a piece of certain plants seen with the naked eye. Placed in concentrated sulphuric acid, the specimen becomes broken apart, and takes on a black color, bordered by a reddish tint. The cells are apparent, some of them separated. Anhydrous alcohol produces no other effect than to detach some flakes of cells, and some rare white crystals, the whole floating on the liquid.

We then took a portion of the knot which had served us for the above experiments, and placed it in water, but its appearance did not change from that of woody fiber, corroded by sulphuric acid.

A portion of knot which we endeavored to completely isolate from the filaments, was magnified to five hundred diameters. Placed in contact with sulphuric acid, it was disorganized, numerous cells made their appearance, and the whole was colored black, mixed with deep yellow ; the addition of anhydrous alcohol has made apparent to us woody fiber, in the condition in which it is when it has been in contact with sulphuric acid.

From the experiments which we have thus made, it follows :

That the Chinese Sugar Cane is composed from outside inwards, first of a layer of cerosie or wax, and an inert epidermis. The dermis contains gums, filaments, fecula, and some portions of sugar.

The interior part of the cane is composed, in very great proportion, of sugar and filaments. It is in the most central portion of all that are found the sacchariferous products.

If the cane be deprived of its epidermis and dermis, it will be placed in the best condition possible to furnish sugar of good quality, and of easy extraction. Such, at least, is our opinion, which is based upon the practical studies which we have made with this precious gramineous plant.

FROM F. BOURDAIS, DISTILLER, AT CONSTANTINE, ALGIERS.

BUT however great seem the probable results of the introduction of the sorgho into France, and however great the enthusiasm which has arisen in the minds of its cultivators, they still look upon the new colony of Algiers as the country in which, both on account of climate, soil and the peculiar adaptedness of the plant, the most remarkable results can be obtained. There, it will be recollected, that M. Hardy, the chief of the government nursery, at Hamma, in his report to Marshal Vaillaint, certifies to having allowed his canes to stand upon the ground where they grew, first having removed the tufts and leaves, throughout the whole winter, the climate being so very mild. The immense importance of such an aid to the manufacture will be seen on a moment's reflection, for he may pursue his manufacture throughout the whole year without interruption, and thus not be obliged to greatly increase his expenditures for labor and considerable machinery to harvest and work up his crop in the short space of time which is absolutely required by the changes of the American climate.

M. Bourdais, a large distiller at Constantine, in the province of Algiers, has written a pamphlet called, "Guide to the Distiller of the Sorgho Sucré," in which he gives the result of his extended experiments. He seems to have been a careful experimenter, and his book is entirely practical; indeed, he says himself, "*All the eloquence of our writings, rests upon the figures offered.*" We quote his language, as follows :

My first experiments were most satisfactory, and I should not hesitate a single moment to pursue with new zeal, in consideration of the initiative taken by M. Hardy, and with the appearance of a new plant capable of giving in alcoholic products according to the figure of this philosophic experimenter, a net profit of about \$1,662 64. Let us remark in passing, that Messrs. Madinier & Lacoste, in the new pamphlet which they have just published, under the title of "Guide to the Cultivator of the Sorgho," carry this figure as high as 9241 fr. Let us remark the enormous discrepancy between these two computations, amounting to \$185 30.

"By taking this figure of 9241 fr. as a basis, it is evident that a planter should, with a capital of \$20,000, distil in six or seven months, the product of fifty acres, and realize thus the enormous profit of \$37,000. Twelve acres were quickly planted by me. Agreements with other persons permitted me likewise to count upon the yield of other estates upon which the sorgho culture had been undertaken. One may judge exactly by the following figures what are the results. The calculation has been made to a most scrupulous exactitude:

COST OF CULTIVATING ONE HECTARE (ABOUT 2½ ACRES).

1. CULTIVATION

Plowing, - - - - -	\$16
Hoeing, - - - - -	8
Making irrigation furrows, - - - - -	4
Sowing, - - - - -	9
Watering, - - - - -	10
Manures, - - - - -	20
Hoeing, and subsequent cost of cultivation, - - - - -	20
	<hr/>
	\$87

2. FIRST COST OF MANUFACTURE.

Cutting the canes at maturity, - - - - -	\$14
Stripping the leaves (done by Arab children, at 1 fr. per day) 28	28
Transportation of the canes to the manufactory, - - - - -	8
	<hr/>
	\$50
	<hr/>
	\$137

By following successive weighings, made with conscientious exactness, I learned the fact that $2\frac{1}{2}$ acres well managed, with the desirable conditions of good culture, yields

1,520 metrical quintals of canes, deprived of their leaves.	
278 " " green leaves, very excellent.	
For the nourishment of stock, and representing, at sixty cents the 250 lbs., a sum total of	\$47
Adopting, as a starting point, the first cost of culture and manufacture, the result above given would be	137
My expenses were thus reduced by	47
	<hr/>
Giving	\$90

I had already a sure basis. Ninety dollars was my entire expense for the product of 520 quintals of cane. I obtained the sum of 84 c. as a representative value for the production per metrical quintal. I will detail in another place the different operations which preceded the distillation. It will be sufficient to say that a metrical quintal of canes yielded, on distillation, 5.2 quarts of alcohol at 94° , being 0.15.1 of raw material for a quart of alcohol at 94° .

Thus, then	
The cost of raw material being,	\$0 03
The cost of crushing, maceration of the <i>bagasse</i> and of the seeds, fermentation, yeast of beer, distillation, rectification, about,	0 10
Cutting and transporting to the still,	0 02
	<hr/>

I obtain, as the cost at Constantine, for the $3\frac{1}{6}$ * reduced to 94° ,	\$0 15
--	--------

This will, doubtless appear a high price, but taking into consideration the extravagant price for manual labor in the province of Constantine, the explanation will be sufficient. In fact, a workman employed either on the farm or in the distillery does not have less wages than seventy to eighty cents per day, for ten hours' work. I have been

* A technical expression, used in France to signify a certain strength of alcoholic liquors. It cannot be translated.

compelled to raise the salary of the chief distiller to \$1 60 a day, which in France is not higher than \$1. It is the same with respect to the fireman, whose wages here are forty cents higher than they are in France. The English bituminous coal which I use costs me at the distillery about \$1 75 per 250 lbs. It will be urged, doubtless, that the native labor would be less costly. The objection would be a valid one, if it were possible to employ the Arabs in any other department than that of manual labor. At a later day, when the culture of the sorgho has become much more extended, and when they have become familiar with it, we may possibly find among them those who would be able to fill the more important places.

I have shown that about a quart of "3/6" reduced, costs me for hand labor about ten cents. This price may appear a high one, but it is not very remarkable. I will show by the following figures that a very large profit can be realized from it in the Algiers market, because of the economy of transportation and other expenses. This economy is not less than 40½ cents. Let us calculate upon the exportation of a pipe of 3/6 of about 150 gallons, to France, at sixty cents per gallon, supposing it put in the hands of a commission merchant in Marseilles.

We will have, firstly, then, to deduct for commission, 3 per cent.,	- - - - -	\$6 48
Storage, carting, guaging, etc.,	- - - - -	1 20
Insurance,	- - - - -	1 08
Freight by steam vessels,	- - - - -	3 80
Commission for transportation to Phillippeville, and various expenses,	- - - - -	1 20
Leakage, and other accidents of the journey, 10 litres, at \$1 80,	- - - - -	3 62
Transportation, Phillippeville to Constantine, at \$2 50 per 50 gallons,	- - - - -	9 20
		<hr/>
		\$26 58

It will be seen that the expenses for an order of 150 gallons are very rapidly increased, before the merchandise can be put into the storehouse, to the enormous figure of \$24 54, about 16 cents per gallon, which would be an entire profit if sold in the interior of Algeria.

In fact, the net price, which we know to have been fifteen cents, is reduced four, and then stands at eleven cents.

For the same reason the price of hand labor is reduced to about seven cents.

It will be remarked that I have abstained from speaking of the seed of the sorgho, when detailing above the productions of this grain. I have made the best employment of this seed the object of a special study, and I believe that I have discovered its most profitable use, taking all things into consideration. It seems to me an undoubted fact, that there is a large profit from changing into sugar the starch contained in the seed of the sorgho, by submitting it to a vigorous and warm maceration, along with the canes.

I previously said, that a metrical quintal of canes yielded me on distillation about five quarts of alcohol at 94°.

In this was included the juices expressed from the seed of the sorgho by means of maceration.

I have passed without notice the so-called product to be obtained from the bagasse, because, like the seed, I submit them to the same maceration, in order to extract from them all the saccharine matter which has escaped the action of the cylinder. I find a further profit in this, since the bagasse, deprived of all its nutritive matter, after the completion of the process of maceration, should not be eaten by stock, as I have proved in my experience. As to a second crop being able to give an additional amount of alcoholic products, it seems to me little probable. We may count certainly upon a second crop, which can give a large quantity of forage to be cut up and eaten.

All the writers who have discussed the sorgho sucré, have also mentioned as one item of production, the cerosie, which covers the stalks of the cane. To my mind it is not worth while to engage in an operation so costly by itself, when the profits resulting from it are very problematical.

The computations I have given are the results of distillation undertaken with about twelve acres of crops made on alluvial soils, or river bottoms, which can be irrigated at high water, and naturally manured by the detritus of the old swamp, where my distillery has been located for a number of years.

The truly surprising results which I have obtained, have been ad-

mired by the Director of the Government Nursery of Algiers, on the occasion of a visit which he was good enough to accord me. He has frequently noticed the existence on my place, of hills of sorgho, tillering from sixteen to eighteen stalks of twelve feet in height, which often were five and a half inches in circumference at their base. In other instances ten to twelve stalks have been very commonly noticed; the average is from six to seven.

It is commonly known that M. Hardy is one of the first who has occupied his time with the culture of saccharine plants, and very especially with the Chinese Imphee. The intelligent experiments which he has undertaken, upon a small scale it is true, (about half an acre,) and as he says himself, deprived of favorable conditions, that is to say, not having at his disposition any other instrument for distillation than Saleron's still retort; these trials, I say, although not permitting him to arrive at results completely satisfactory, have not however suffered him to have any doubt upon the future of a culture which promises to be an inexhaustible source of riches and prosperity for Algeria.

Although it has been necessary for me to cultivate my grounds at great expense, (at first with the pick, to eradicate all the stumps and stubble of the old swamp; afterwards with the plow, to bury as deeply as possible by very arduous labor; and finally to make ditches and drains, for the aëration of the soil,) the result has amply repaid me for all these labors attending the first cultivation. I will now confine myself to the details relative to the fabrication of the wines of the sorgho, to their distillation, and finally to the rectification of the brandies which have been obtained from it. I will explain as clearly as possible different methods I have employed; and I shall deem myself happy if these reflections can open the way to other investigators.

DETAILS OF MANUFACTURE.

The canes, stripped of their leaves, are submitted to the energetic action of a cylinder, with three rollers moved by steam, and making fifty revolutions in a minute. The *vesou*, or juice, runs into a vat of a capacity of about one thousand gallons, placed under the cylinder. This first operation finished, the bagasse passed out of the cylinder contains still a large quantity of saccharine matter, which can be extracted in scarcely

any other way than by maceration. This new operation is, however, more indispensable, as the saccharine part remaining in the bagasse gives in maceration for 2500 lbs. of these latter, 500 gallons of juice, weighing 3° by the areometer of Cartier.

Thus, then, 260 lbs. of canes yield, in reality, seventeen gallons of *vesou*, at a density of 10°, or, as we have already said, five quarts of alcohol at 94°, being two gallons of alcohol to twenty-five gallons of juice. But it is impossible to obtain these results if recourse is not had to maceration. Thus there will be seen the motives which have induced me to seek for the better employment of the seed of the sorgho.

When I perceived that the cutting and stripping cost me so much, I caused to be made in the fields of the plants which were growing, a choice of the finest grain for my sowings of the following year; and I left the panicles adhering to the stalk. Of the remainder, the panicles and leaves should be crushed in the cylinder and afterwards subjected to the process of maceration with the bagasse. The action of the warm water determining immediately the transformation into sugar of the starch contained in the grain, I was able to obtain by a single operation the saccharine residue escaped from the cylinder, and to save thus the cutting off the seed, stripping, the grinding of the grain, and the trouble of the preparation of a certain quantity of malt to assist in the fermentation. The possibility of leaving for some time standing in the field the plants of the sorgho, has considerably assisted me in this experiment; for, as M. Hardy judiciously observes, the stalks of the sorgho preserve themselves not only uninjured for several months after their maturity upon the ground as they grew, but even increase in the proportion of sugar. I find proof of that in the specific weight of the juice, which in September last weighed 9° and now has increased to 10°.

FERMENTATION.

The juice as it passes out from the vats from maceration, is enriched by the addition of pure juice, and arrives in the fermenting vat with a density of 5°. I have made what is technically called the "foot;" that is to say, by turning into a vat 200 gallons of juice at a temperature of 30°; with this 5 quarts of brewer's yeast should be mixed; an

hour afterwards this "foot" is in full fermentation. I then filled my vat with 500 hectolitres, at a temperature of 30°. An hour after these quantities pass themselves into fermentation. Let us remark that this is the result of our own experience; that this fermentation progresses regularly, has no need of being watched, is never violent, and falls always to zero of the areometer, in 20 hours at least, and 24 hours at most. It is very true that the juice of the sorgho contains naturally its own ferment. M. Hardy has considered it sufficient to produce the alcoholic fermentation without the addition of any stimulant; and in this latter case this fermentation progresses very gently, much too gently even, since it requires less than 6 to 8 days to fill; and finally it often happens that it ceases before the sugar is entirely transformed. Then the wines weigh still 1, and sometimes 1½, by the areometer.

DISTILLATION.

I distil my wines by steam, and by means of a column still, after the system of M. Dubrunfaut.

RECTIFICATION OF BRANDY.

The rectifying column of which I have made use is that of M. Dubrunfaut, comprising two analyzers, whose purpose it is to spread the liquid of the condensation and the vapors, which are obtained simultaneously. The 3|6 obtained are of a strength of 94°, and fine in flavor. It now only remains to present a summary view of the figures which have appeared in the foregoing remarks, and to draw the attention of the reader to the following conclusions: they speak for themselves, and have no need of comments. We have seen that about 2½ acres can produce 58,240 lbs. of stripped stalks; and that a hundred kilogrammes (225 lbs.) of these same stalks may give about 1½ gallons of alcohol at 94°. The hectare (2½ acres) yields then about 700 gallons 3|6 at 94°, worth in the Constantine market about \$1 50 per gallon, say \$1,081 60

We know that the litre of 3|6 costs, all expenses included,
 0.74.1, say for 200 gals. 400 73
 There remains, per hectare, a net profit of \$680 87

In the preceding calculations we have examined the question of the sorgho in all its relations, both as to the process for the transformation of its product, and the farm which gives them. In a word, it is certain that an establishment thus constituted can distil in the space of six or seven months a crop of about 50 acres, and produce by an expense of \$20,000, (in which is comprised about \$17,000 fixed capital, represented by the apparatus and works,) a profit of \$12,000, or thereabouts. We have said the sorgho not only furnishes to industry a precious element; but furthermore, it can profitably be employed as a forage crop. One acre cultivated in sorgho costs less for culture, and pays incomparably more than the best artificial meadow. They have already comprehended this in the north of France, as is shown in one of the pamphlets previously quoted; but in those countries where the sorgho does not ripen, planters have to overcome difficulties which do not exist for us, and are far from being able to obtain, notwithstanding all their efforts, results equivalent to those which come in this country without other assistance than native labor.—[From "Guide du Distillateur du Sorgho a Sucre." F. Bourdais.

REPORT OF THE COUNT DE DAVID BEAUREGARD,

TO THE AGRICULTURAL ASSEMBLY OF TOULON, UPON THE ALCOHOLIZATION OF THE JUICE OF THE SORGHO SUCRÉ. TOULON, 1857. .

WE are aware of the fact that the juice of the sorgho, whose introduction we owe to M. Montigny, has within itself all the ferment necessary for the transformation of its saccharine matter into alcohol. It ferments with such activity under a sufficiently elevated temperature, the formation of a great quantity of alcohol is so rapid that this reacts upon the ferment, of which a portion precipitates itself before having had time to accomplish its useful transformation.

Thus it often happens that one, two, and even three degrees of sugar remain still in the wine of the sorgho at the moment when the fermentation ceases. To this first cause of loss there is frequently added another, when large vats are made use of.

The temperature, under the influence of this tumultuous fermentation, arises in these great masses, even so far as to acquire, in warm weather, from 35 to 40 degrees centigrade, which occasions a still further loss of a considerable quantity of alcohol.

Desirous of avoiding the viscous fermentations which cause so much loss in sugar beet distilleries, when the proper degree of heat for the ferment is wanting, I heated my juice to 25° before putting it in the vat, which I rapidly filled, and added to its various ferments. I not only accomplished my purpose, but even got more than I desired. The fermentation proceeded with great violence. The imaginary inconvenience which I wished to avoid occasioned me a serious and a real one. The heat and ferment only aggravating the conditions of the operation, and I was not slow in perceiving that we obtained as much less alcohol as the fermentation had been more lively, and that there remained finally in the wine as much more of sugar in an unchanged state.

I have since then been led to follow an entirely opposite course, seeking to render the fermentation as mild as possible, but however to make it complete by sustaining it at every moment. I avoided all use of ferment in the juice of the canes, and I have made my vat of a temperature as near as possible from 10° centigrade to zero.

To obtain this temperature when the weather is warm enough, in September or October, it is well to treat only the canes cut the evening before, and which are stacked against the north side of a wall to profit by the moisture of the night. The juice likewise should be caused to run into the vat in a continuous thread. Into the vat is also introduced, at the same time, a thread of fresh river or spring water, and if this should not be had, water from clean well-built wells.* The diameter of this thread of water should be calculated, so that the mixture of the two liquors shall mark 60° on Beaumé's Glucometer. If the machine discharges more of juice than is necessary to obtain this density and this temperature, the necessary number of vats to regulate that should be simultaneously filled. When frost comes it is necessary

* The mode of feeding can be altered. After a first vat full, in place of water, vinasse taken from the still retort can be used, or, better still, the results from the maceration of the bagasse.

to warm the mixture to obtain this initial temperature of 10° centigrade. In this case the water added is heated, and not the juice. It is necessary also, when the temperature of the juice is below 10°, to elevate the temperature of the water, so that it shall exceed 10° above zero as much as it lacked of arriving at this point during the night preceding the filling of the vats.

Despite this low temperature, fermentation commences even on the first day, and thanks to the manner in which it commences and to the mode of feeding, it is maintained mild and regular, transforming every day into alcohol a sixth part of the sugar contained in the mass, and making it gain two degrees of heat from the initial temperature,* so that on the seventh day, my vats, of a capacity of about 250 gallons, contained nothing but a liquid marking zero on the glucometer of Beaumé, and 22° of heat on the centigrade thermometer.

If it has gained only two degrees of heat in twenty four hours, it will be found that the transformation of the sugar into alcohol is diminishing, and the water should be heated to cause the mass to arrive at the desired temperature during that day.

This will only happen when the outside temperature is very low. It will be seen that the thermometer and the spirit gauge are two instruments which must be employed, *unless the operator wishes to go blindly to work.*

The sixth day, that is to say, as soon as my vat is filled, I stir up the mass with the hand, to replace in suspension whatever portion of the ferment remains unappropriated. The next morning the transformation is perfect. My wine is made; but to abstract from the alcohol a slight peculiar taste, due to the presence of certain essential oils which it contains, I throw that day into the vat two kilogrammes of powdered quick lime, (about five and a half pounds, troy,) previously slacked with twenty litres of water, (six gallons,) and again rapidly stir it up with the hands.

The lime unites with the essential oils to form an insoluble compound, which is precipitated.

We will let the fluid remain quiet for two days, and we then distil

* On the morning before recommending the distillation, the state of the fermentation and the temperature of the vat should especially be examined

it in the Derosne apparatus, and obtain in alcohol "3|6" of an agreeable taste, reminding one somewhat of kirsch, almost as strong per cent. as the juices indicated of degrees on the Beaumé glucometer, say usually from eight to ten per cent.

This result, which I invariably obtained since my change of system, seems to me of such a nature as to give confidence to those who, up to this time, have not dared to undertake the culture of the sorgho, and also to favor the establishment of distilleries, where the profitable manufacture, on a large scale, of the crops brought in by the farmers of the neighborhood can be undertaken.

But in this regard, gentlemen, and to enlighten those who would be tempted to organize an enterprise of this nature, I believe it is useful to add some words on the method I have employed up to this time, to extract the juice of the cane. By mentioning the advantages and disadvantages of my process, I can enable others to profit by the experience, and do better.

You already know, gentlemen, that to extract the juice of the canes, I pass them between plate cylinders, as is done in the colonies with tropical sugar cane. This mode of extraction, sanctioned by long custom, has seemed to me, more prudent to use at first; but in order that none of the juice may be lost, it is requisite to key up the cylinders very closely, which requires the employment of a strong motive power.

When the operator can make use of a strong and natural force, a fine waterfall, for instance, the inconvenience which we notice is no longer met with; but if this cannot be obtained, it would be well to try some other mode of extraction, requiring less motive power. A crusher, a stalk or straw cutter, or other similar instruments, can accomplish the end desired.

The state in which the canes are found, according to the mode adopted for dividing them, will naturally necessitate particular arrangements in the work for the extraction of the juice, their fermentation and their distillation; but this is not the place to enter into the details of the subject. I wish simply to guard you against the idea that the crushing cylinders will be found to be, in all circumstances,

and in every case, the most suitable method of extraction to be employed.

* * * * *

Of the other aspects of the culture of the Sorgho, I shall not speak at present, but having confined myself to the particular department of alcohol manufacture, on which much light was needed, I shall esteem myself happy, gentlemen, if I can contribute to extend the culture of a plant which, for many reasons, seems to be one of the most precious which Providence has ever placed at our disposal.

COUNT DE DAVID BEAUREGARD,

President of the Agricultural Assembly of Toulon.

TOULON, Dec. 2, 1856.

ON THE SUGAR SORGHO AND THE IMPHEE.

BY DR. TURREL, SECRETARY OF THE ASSEMBLY OF TOULON.

[From the Bulletin of the Imperial Acclimation Society.]

The question of the sugar sorgho has taken an importance in agriculture, not only because of the yield in alcohol of its sweet stalks, but, still further, because of the coloring matter of its seed, and of its production of seeds which are capable of serving as means of food for man, and for fattening cattle.

It is, then, perfectly natural that persons should occupy themselves with this cultivation; but, however, we would not wish that an inconsiderate haste should make us lose sight of the conditions on which it is dependent for being largely remunerative. These conditions seem to us essentially to be—

1. A combination of rural industry and agriculture.
2. Large cultivation.
3. The remoteness of sufficient markets for usual crops.

The cultivation of the sorgho as a source for the production of alcohol, cannot be undertaken without a manufactory connected with the

farm, because the raw matter is very cumbrous, difficult of transportation; and supposing even the establishment of a central distillery in the middle of an agricultural district fit for the culture of the sorgho, it is probable that the cost of transport would be very high, and that because of the rapid change of the saccharine matter by spontaneous fermentation in the masses of the stalks, the greater part of the saccharine richness would be lost for the producer and to the manufacturer.

It is in the field that the sorgho preserves most completely its properties, a precious peculiarity for Algeria, as the different reports of M. Hardy prove; for Guadaloupe, as M. Grellet Balguerie writes to us; and in similar climates.

Cultivation on a large scale* seems to me fitting for making profitable the cultivation of this plant. This opinion is the irresistible conclusion to which we arrived. The cultivator on a large scale can afford the cost of manufacture: plate cylinders, hydraulic presses, fermenting vats, and still retorts. Small culture would be entirely unable to make similar expenditures; and on this scale sorgho should be cultivated only for the production of seeds—that is to say, in the light of a product less remunerative than the cultivation of vegetables, or, very exceptionally, for the extraction of the fermentable saccharine matter, as a sort of recompense or substitute needed because of the grape disease in vine countries, where wine is no longer grown.

With this view, in the districts near Toulon the landholders have mixed in their vintages and fermented with grape juice the liquid extracted from the sorgho, and obtained wine more abundant, and without any unpleasant flavor. This mixed wine, whose production has been very limited, was unfortunately consumed at home by the families of the cultivators.

Further, cultivation on a large scale could not be undertaken with

* We are in position to affirm that a society, important because of the honorable names attached to it, has been formed in Paris, with a view of making experiments on a large scale. This year, even, it will undertake the manufacture of about 85 acres of sorgho, which have been cultivated in the neighborhood of Bayonne. We might quote the names which are at the head of this Association, called an Experimental and Protective Imphee Association, which has a great future; but we prefer to wait until we are able to quote the facts arrived at, and that will not be a long time.

the sorgho, except when there was no readily obtainable market sufficient to warrant richer crops and of less difficult production.

In the *arrondissement* of Toulon, for example, the crops on the reclaimed swamps, and the fruits cultivated in irrigated soils, give an average net profit of 500 francs to the hectare.

It is difficult to guarantee to the culturer of the sorgho a greater profit in the absence of a distillery devoted exclusively to the manufacture, on a large scale, of this plant, when the cost attending it are taken into consideration.

Far from the city, on the contrary, and where grazing of cattle can be undertaken on a large scale, the sorgho *sucré* can become as an average plant when the price of alcohol has decreased: of very great importance, because it is greedily sought after by cows and horses.

Pigs even crunch with delight its succulent and saccharine stalks. They devour the seeds, which, M. Grellet Balguerie thinks, can be given to horses in place of oats. Finally, in the form of flour, this seed will become, because of the abundance of its yield, an excellent means of fattening cattle for the butcher.

It is especially because of this peculiarity that we think favorable notice should be taken of a new species of sorgho *sucré*, whose introduction into Provence we owe to M. Grellet Balguerie, of Guadaloupe. This sorgho, which has been the object of the studies of Mr. Leonard Wray, under the name of *imphee*, or Kaffir sorgho, is, in all probability, the one upon which, in 1766, Pietro Arduino made his experiments in Italy. This is the opinion of M. Grellet Balguerie. "The description of Pietro Arduino," says our correspondent, "seems to apply very exactly to the *imphee*, which we cultivate in the Antilles."

M. Grellet Balguerie specially congratulates himself upon the yield in seed of the *imphee*, which is much superior, in this regard, to the sugar sorgho; the latter, however, being preferable, because of its more early maturity.

In Martinique, M. Hayot cultivates, with profit, the *imphee*, simply to feed his Indian coolies with the flour of its seeds, which he finds preferable to coolie rice, and with more nutrition in an equal quantity. He gives its leaves to his cattle, which are fond of it; and manufactures of its saccharine juice an excellent taffia.

The sorgho *sucré* and the *imphee*, then, recommend themselves in the

three different points of consideration—the production of alcohol; as a forage plant; and as a food by their seeds, which, if it is desired, can also be converted into alcohol in prolific seasons. But the sugar sorgho offers to industry a new and rich product. The coloring matter extracted from its seed is of a beautiful solid carmine, and the Lyonesse manufacturers are seeking it for tinting their silks. This is a new source of riches for the agriculturist, if he knows how to make use of them.

We cannot accept as serious the calculation of M. Hardy, which shows, as one of the profitable products of the North China sorgho, the cerosie, or vegetable wax, which develops itself upon the surface of the stalk. The same waxy substance is found upon all the sorghos, upon the sugar cane. However, it has never been sought, to make use of it, except in the laboratory, and for the gratification of chemical analysis; for, supposing that the costs of extraction were sufficiently covered by the product, the scarcity of labor, which is especially felt in the farming districts, would form an invincible obstacle to its being undertaken, especially in Algeria.

One of our honorable correspondents of Turin, M. le Count Moignerie, has made vinegar by watering the bagasse, already crushed, with the juice of the sorgho. He has obtained the acetous fermentation, and, according to his own testimony, a very perfect vinegar.

Count de Beauregard has gathered about 135,000 pounds of stalks to the hectare ($2\frac{1}{2}$ acres). He has extracted from it about 7,600 gallons of saccharine juice.

M. Raoul has obtained about 100,000 to 112,000 pounds of stalks, and has obtained from them from 50 to 55 per cent. of juice.

From the preceding observations, it follows that it is especially desirable for our agriculture to accomplish the distillation in the shortest possible time comprised between the last days of September and the first of November; for frosts, by congealing the juices in the stalk, alter and destroy the greater part of the saccharine matter, which ferments without giving profit, when the stalks, cut at maturity, remain crowded together under sheds. It is always more profitable to treat them at the moment when they are cut. In this point of view Algeria offers an immense advantage to its agriculturists, since the

sorgho can there remain on the field, without freezing, for the whole winter.

It is evident that in the vine countries, the harvesting and manufacturing of the sorgho sucré, coinciding with the time for the vintage, which occupies all the desirable forces, would there offer to cultivators great difficulties to be overcome.

The saccharine richness of the stalks not seeming to diminish by the fact of the maturity of its grains, it is very much to the interest of the cultivators to allow it to ripen, and the yield in seeds may be estimated at nearly 150 bushels to the two and a half acres (sixty bushels to the acre), weighing each from 175 to 200 lbs. We will conclude by a statement much exaggerated as to cost, much moderated as to profits, upon the culture of the sorgho on about two and a half acres of ground.

Cost of culture and manuring, about	-	-	\$60
Cost of distillation per hectolitre of alcohol, at six dollars			
per fifty-eight bushels,	-	-	120
Topping and stripping of 125 acres of seed,	-	-	20
Total costs per hectare,	-	-	\$200

PROFITS.

Twenty hectolitres of alcohol, at about \$7 15,	-	-	\$400
145 bushels of seed, at about \$1 45 per bushel,	-	-	200
Coloring matter of the seeds?			
Total cost receipts,	-	-	\$600
Total expenses,	-	-	200
Net profit to the hectare,	-	-	\$400

This sum of \$400 in net profit, which results from the figures of the cost, comprising the interest on the capital employed in the industrial manufacture, represents a profit sufficiently high to encourage the industrial cultivation of the sorgho, wherever an addition of the suitable machines can be made to a farm. We have purposely avoided mentioning the value of the leaves as a forage, in order to make better understood the particular interest the Zoölogical Acclimation Society takes in the extension of this culture.

THE SUGAR SORGHO.

CULTURE, HARVESTING, USE OF THE SEED, EXTRACTION OF THE SWEET JUICE, DISTILLATION. By PAUL MADINIER. Paris, 1857.

CHAPTER I.

CULTURE.

For several years past, French agriculture, stimulated on all sides by intelligent and industrious men, who work without relaxation for the improvement of the system of agriculture in our country, has been occupied especially with the grave question, not new, it is true, but which had not arrested the attention of the masses before: the naturalization among us of the sugar sorgho. This is a subject of great interest for all, and more especially to the laboring man, with whom it is actually a luxury, used by him only in cases of sickness. There is room for astonishment at the dearness of this alimentary substance, since the investigations of science have found it so largely prevalent in the vegetable world, more especially because the prospect of abundant supply should apparently make a proportionally good market for it, by inducing greater numbers of persons in moderate circumstances to become purchasers, who otherwise could not.

In fact, we may say, other things being equal, that the price of a product is not so much a matter of pure conventionality, that speculation alone can materially change it. The price of an article of merchandise rests on its greater or less abundance, and, at the same time, on the amount of work needed for its production. This last condition is very important, for the more the methods of extraction and preparation are perfected and simplified, by so much the more does it become possible to furnish it at a lower price. However, when we find a substance very rare, which after a protracted search gives moderate returns, the simplification of the process of manufacture does not produce a very marked reduction in price, and for very obvious reasons. Thus, to apply this reasoning to the subject in hand, the

nitrogenized products, very rare, are exceedingly dear, whilst carbonized matters (starch and sugar) are sold at a much lower price, by reason of the profusion with which they are found in all the vegetable kingdom.

If we dwell somewhat at length upon these considerations, it is to show that the high price of sugar is a profound anomaly, contrary to the universal laws of production, and which should certainly disappear after a short time. And this anomaly is so well understood, that it is with a lively enthusiasm that the appearance of this sugar sorgho has been greeted, and that the alcoholization of topinambour and sweet corn has been adopted. Thus, what a haste is shown in all France to commence the cultivation of this Chinese sugar cane; how everywhere each makes a trial; this one on whole hectares, that one on small plats, even upon the corner of his garden.

Nevertheless, up to the present time, the sugar sorgho has not been used nor manufactured to any considerable extent, except as an alcohol producing plant. Decisive experiments will not long be lacking to decide upon the yield of sugar. But even admitting, which we are very far from believing, that the sorgho cannot give crystallizable sugar, it still will exercise a wide influence upon the production of saccharine matter. It is easy to be understood that the South undertaking the alcoholization of a plant much superior to the beet, would so interfere with our departments of the North, that they would be obliged to restrain themselves entirely to the manufacture of sugar.

Although highly supported, the sorgho has not failed to have detractors; for example, they reproach the sugar sorgho with being a very exhausting plant. They say that its enormous profit is very greatly reduced the moment that you deduct the cost of gathering, manufacturing, and the damage done to the soil by its culture. Fortunately, it is not difficult to meet these objections, and to show their slight weight. It will suffice us for that to rest simply upon the authentic facts already known, and upon others more recent, but not less irrefutable. Let us endeavor to apply to the sugar sorgho, the rules in use with the different scientific agriculturists to determine the action of vegetables upon the soil. We see that the sorgho is a plant of rapid growth, is but lightly shading, and as a gramineous plant, may, in truth, be ranked among those which take much from the soil; on

the other hand, we observe that this vegetable, poor in nitrogenized matters, should not much impoverish the soil of the most precious ingredients, for the leaves of the sorgho, being eaten by cattle, produce manure. The canes, deprived of their sweet juice, may serve as long manure, or even for forage, and the seeds, which will be profitably consumed on the farm, in the form of soups and broths for man, or for fattening animals, will also furnish its proportionate return. In a word, it is clear that the nitrogenized matters are returned to the soil, and it is only the carbonaceous matters which are employed for manufacture, consequently there are in the cultivation the most remarkable conditions of an improving and progressive agriculture.

We will here add the following results to explain this mooted question of the exhaustive action of the sorgho. Admitting for a yield the figures of M. Hardy, we find,

CROP.

Stalks, 215,000 pounds;	dry matter, about	64,000 pounds
Leaves, 54,000	“ “ “	16,000 lbs. Troy.
Seeds, 96,000	“ “ “	9,400 “

89,000 lbs. Troy.

Admitting that the impoverishment of the soil by the sorgho be fifty per cent. of the dry matter, we have 45,000 lbs. of impoverishment, which requires 400 of manure for 100 of impoverishment, say 180,000 lbs. of natural manure.

We should deduct from this total the amount of manure furnished by the crop itself. We have

Roots left in the soil,	- - -	8,000 lbs. Troy.
Bagasse (supposing that it is deprived of its water of vegetation),	- - -	175,000 “
Leaves,	- - -	54,000 “
Total,	- - -	<u>250,000 lbs. Troy.</u>

Which we may consider to be worth 60,000 of hay (taking the equivalent of 400 of the millet), giving, at least, 122,000 lbs. of manure. Thus, on the 175,000 lbs. to rise upon the two and a half acres for the cultivation of the sorgho, there is of manure 122,000 lbs., which are

produced gratis, while the transformation of the forage which this quantity gives, results in a still further profit in the nourishment for cattle. It is, then, 56,000 lbs. of manure that we really pay to obtain the seed and the saccharine juice of the sorgho.

M. De Gasparin estimates that two thousand seven hundred and seventy pounds of manure are necessary to produce 2·84 bushels of Indian corn (seeds and stalks.) Supposing that the sorgho is more exacting, and needs two thousand nine hundred and thirty-five pounds Troy for 2·84 bushels, that would make for a yield of nine thousand six hundred pounds of seed to 2½ acres, 160,000 pounds of manure necessary.

Let us consider finally the testimony of a person who is certainly the most competent upon this matter, M. Beauregard, who for the past three years cultivated the sorgho upon the same land, without having experienced any diminution in its yield. We will now consider the choice of the soil which is most suitable to the sorgho, and also pass in detail the methods of cultivation most appropriate. This plant flourishes in light soils, sandy and calcareous, and particularly in alluvial formations. It needs a certain moisture, but is averse to it in the extreme. Almost always, both in Algeria and the Mediterranean district of France, excellent results will be obtained from the employment of irrigation, both during the early and more advanced stages of the growth of this plant; but as it approaches the ripening of the seed, it is not so profitable to employ irrigation, and is even detrimental, by hindering the elaboration of the saccharine principles, and causing the canes to be watery. Mr. Hardy, the illustrious Director of the Government Nursery at Algiers, tells us that the sorgho delights in soils containing carbonate of lime, and he advises frequent liming of those which need it. This recommendation is explained by the astonishing success of the sorgho upon the chalky soils of Champagne, where they have obtained but very slight crops. If the use of lime seems beneficial, it is not the same as regards the employment of salts, of which we know the depressing influence upon the sugar cane and the beet. As a fertilizer, the excrement of horned cattle is very excellent. Manuring with green crops cannot be too much recommended in this cultivation. They increase the fertility of the soil, render more assimilable

the materials which compose it, and preserve in it a more constant moisture. In general, the fertilizers formed by vegetable matters undergoing decomposition, are more efficacious for sacchariferous plants. The land destined for the sorgho should be well prepared by deep plowing and deep harrowing. It is necessary that it should be a certain depth. The plant thus gains a stability, and finds itself to make a more rapid growth, besides having at its disposal more moisture. The plantation can be made in two different ways—by sowing in a hot-bed and transplanting, and by sowing in the field. In Algeria and the south of France this last method will be preferred. For a great number of localities in the center of France, the Chinese method of replanting will be more profitable, but with the condition that labor shall be abundant.*

The field sowings should be made when the late frosts are no longer to be feared; that is to say, in Algeria during the month of April; in France, from the middle of April to May, according to the position, more or less northern, in which we find ourselves. It is good to sow when the earth is a little moist on the surface, because then the seed, which requires to be slightly covered, germinates more rapidly, and grows very vigorously. It would even be well to water the ground if it was too dry at the time of planting.

It is the practice to sow in lines of different width, according to the situation, in Algeria. Mr. Hardy has adopted three feet two inches as his width. In Provence, several agriculturists have chosen a width of about three and a quarter feet. But this is a matter of choice and locality. Sowing in the hot bed is done in March and in April, upon a border sheltered from cold winds. The plants are transplanted when they have acquired a height of about fourteen inches. For the field sowings, the first hoeing is given as soon as the sorgho has attained about fourteen inches of height, and at the same time is thinned out from fourteen to sixteen inches in the rows. The superfluous plants can be fed to cattle. In the course of the vegetation of the sorgho,

* M. Itier, who has recently given us the details of the culture of the sorgho in China, recommends strongly the adoption in France of the system of transplanting. For our part, we do not believe it will succeed; at least, that it will not be adopted as the profitable practice of cultivating sorgho in the thickly populated districts of the North. * * * * *

there could be given frequent hoeings and cultivations. These are necessary to obtain good results; for, as we have previously seen, the gramineous plants, which harden the soil, exact, as a condition upon which they will yield the best results, a very complete and thorough cultivation.

For irrigating, you make little furrows at the foot of the lines of the sorgho, and water is caused to run through them as often as the state of the plant and the season admits. Arrived at this point of the growth of the vegetable, an important question presents itself for our examination. Should we hill, or should we not hill? M. Hardy tells us that hilling is necessary to insure to the plants the means of resisting winds, and to favor the growth of advantageous roots, which are thrown out by the sorgho, as with the corn, at the bottom of the stalk. Dr. Sicard thinks on the contrary, that hilling is dangerous. He explains his opinion by this fact, that the Chinese Sugar Cane has need of roots elevated above the soil, taking from the atmosphere the food furnished, without doubt, by the superincumbent air, and an elaboration of the sap, which is due to the contact of its roots with the soil. The comparative experiments made upon the same field of sorgho had been entirely favorable to the canes which were not hilled.

In reality, in a soil in good condition, the roots of the plant can penetrate so deeply that they can resist the effect of the wind. Upon the question of adventitious roots and the hilling, we cannot definitively decide, because of our want of decisive experience. However, we believe, since its roots are provided with spongioles or suckers, that burying them cannot be injurious if hilling is moderately used, so as only to cover a little of these roots in such a manner that the air, being absorbed by the soil, can stimulate them, and aid in the decomposition of materials that they may absorb. We know that the roots of the cereals are so superficial that they take away from the soil much, because they grow in a limited circle, and that the loosening of the soil augments its permeability for the atmosphere, and the gases favorable for vegetation which are contained in it give an activity much greater for the growth of the plants whose products are found considerably increased by these means. We believe, then, that these adventitious roots may be covered by hilling, if only we do not suffocate them under

too great a mass of earth, and that we cover them, as much as possible, with soil of a good quality, in order that their power of assimilation may better develop itself, and produce the greatest benefit to the plant.

CHAPTER II.

HARVESTING—USE OF THE SEED—EXTRACTION OF THE SWEET JUICE.

THE sorgho should be gathered when the seed is completely ripe, that is to say, when it shows a deep chestnut color; when it turns to carmine, the commencement of fermentation is indicated. Plants are cut in a rough way, (while we are waiting for the invention of machines for the harvesting of sorgho upon the plan of those which already exist in the United States for the corn,) and then transported to the sheds or to the manufactory where they are to be worked up. They are stripped, and then deprived of their tufts in various ways. One of the best consists in placing the bundles of canes on a platform, by the side of which they place some kind of a box or other receptacle. The workman, drawing towards him the stalks, cuts off successively the tufts, which fall to his right in the box. These are then taken away, and placed to dry with care. The least moisture which shows itself will deteriorate the seed.

The separation of the seed is accomplished with flails, or thrashing machine of some sort. The heads which bear the grain being of a very woody nature, may be employed as kindling to feed the fire under the boilers. The canes of the sorgho, when the season is propitious, that is to say, when it does not rain, may be preserved some considerable time. It is much better, in this case, to leave them with their tufts, and not to strip them, except at the very time when they are to be used; or, as in Algeria, the plants may be left in the field where they grew, as also in the southern district of France. In that case the panicles are removed for fear of loss of the seed. Unfortunately, these means are not sufficiently general and positive. They can never place at our disposal more than two months of time, and that generally is

not sufficient for the manufacture. It is to be hoped that experiments may be undertaken for the preservation of the canes in pits or by other methods. The preservation of the juice as M. Vialle practices, merits some commendation, and offers a great field for research, and much reward for the labors bestowed upon it. After several years of experiment, it is probable that experience on one part, and researches and investigation on the other, will resolve, in a satisfactory manner, this problem of prolonging, for four or five months, the season for distilling the sorgho.

It has been said, with a certain degree of reason, that in the South and Algeria, the harvesting and treatment of the sorgho coinciding with the vintage, which occupies all the hands, there would, in that case, be for our farmers a great difficulty to be overcome. Let us observe, however, that the harvest of the sorgho is very simple, that it will be very much lightened by the addition of mechanical appliances, and that, after all, it is possible, though, in some degree, restrained, to retard the epoch for manufacture. Finally, as to suitability of soils, the sorgho will not find itself adapted to exactly the same localities, and thus the difficulty would be obviated.

Finally, admitting the fact that a real embarrassment is caused by the coincidence of the time for these two harvests, there will not result from it other than a very good effect. The introduction into the South of agricultural machines for taking care of the sugar sorgho; for every one hearing this plan spoken of, and wishing to profit by the advantages which it brings, will be obliged to make use of machines to be drawn by animals. On the other hand, the other cultivations will be simplified at the same time, and the vine and the sorgho will profit by it; whilst, in the other case, the gathering of the crop bunch by bunch, and the numerous difficulties which manufacturers would have, would remain almost the same as now. On this subject we will remark, that it is well to understand that the most minute manual operations gain vastly by being executed in a systematic manner; and the grains of these two harvests, so similar in pecuniary profit, will compel a simplification and systemization heretofore overlooked. In bad processes of manufacture, with bad utensils, with directors and laborers lacking intelligence, a large portion of time, at the period of harvest,

is lost. But what a different appearance does a well regulated farm present.

Before entering upon the details of the application of the sorgho to general purposes, we will say some words upon the improvement of wine, by means of this plant.

It is the custom in bad years, when the latter end of the summer has been rainy, to add some glucose to the vats, which are in fermentation, for the object of supplying the lacking proportion of sugar, which has not been elaborated in the grape in a suitable quantity. To this end, a few have tried, in different cases, to replace the dregs by canes of sorgho rudely broken, and very excellent results have been obtained by this means. We think it useful to recommend this custom in all cases when the harvest may have turned out bad in the localities situated near the North. We know, for example, that the wines of the neighborhood of Paris, contain little of alcohol or acid, and do not keep well. As to their earthy taste, sometimes very marked, it generally arises from the excessive quantity of manure, and not of the best, that is applied to the vine. With the sorgho the amount of alcohol will be increased, and we will be assured of a longer keeping if we will perfect the quality of the wine, and very likely abolish this disagreeable taste of which we have spoken. But to accomplish this transformation, this real revolution in the vintages of Parisian life, what is necessary? Simply to sow in April, some sorgho in a hot-bed, or in a warm border, replant it in the middle of May, in a well sheltered corner of the field, exposed to the sun, or even in a somewhat more exposed situation, if there is not much reason to fear the effect of the wind. You certainly will not gather from that the seeds, but you will have good, and very fine stalks, containing, at least, ten to twelve per cent. of *marc*; but the possibility of this latter is proved in the perfect success of the experiments on the sorgho of M. Jomard, at Lozere, near Palaiseau, and of M. Vilmorin, at Verries.

As a forage plant, the sorgho has a great interest. From the South to the farthest northern extremity of France, it will be cultivated with profit for this crop, which it yields in such great profusion. In the southern departments and in Algeria, by the assistance of irrigation, it will acquire a great importance, by reason of the abundance of its yield,

because it will suit exactly by its composition for the nourishment of milk cows, for which it will undoubtedly replace the beet. It will compose the food for the females of the races of our working cattle, which are very poor milkers, almost incapable of nourishing their calves, and for which it is necessary to furnish, during the time of suckling, the kind of fodder adapted to the secretion of milk.

The seed, of an elongated spheroidal form, is enveloped in its firmly adhering valves, which are impregnated with a very intense coloring matter, found even in the interior portion of the seed. It contains from ten to twelve per cent. of nitrogenized matter, and about sixty-six per cent. of starch; a composition which, upon the consideration of the amount of nitrogen, reminds one of Indian corn. The yield of seed is large, but not exactly established at the present time; but we know enough of it to be assured that it could not be inferior to that of the millets, and of the common kinds of Sorgho, such as broom corn. We may then calculate upon eighty five to one hundred and forty bushels (probably, per hectare, two and a half acres,) in ordinary circumstances, but with good cultivation we may obtain very much more. However, it is necessary to make, in this respect, an important distinction in the yield of the seeds of the sorgho. According to the observations of science and practice, the saccharine plants are excellently well grown in the soils composed of vegetable detritus, or humus, not too rich in mineral salts; plants bearing seeds for food, do not require lands too much charged with humus, but they allow of the presence of a notable quantity of mineral salts. Those of the first sort can receive, without great inconvenience, excessive manuring, provided that they contain but little of animal and mineral matters. The second, on the other hand, profit entirely from the presence of these substances, but they do not require strong manures. The excessive use of these latter, commonly results in producing a great excess of straw. From these considerations, it is evident that the sorgho, cultivated especially for its saccharine principles, will produce seed in quantity very different, according as it is cultivated in a soil favoring more or less this crop; and everything goes to prove that a culture perfect for the elaboration of the saccharine principles of the vegetable would be singularly injurious for the formation of seed. It is thus that we explain the very

dissimilar appearance of the tufts coming from soils of different nature, and the great dissimilarity in the yield of seed of the sorgho, as stated by the different persons who have cultivated it.*

The bulk of the seed of the sorgho sensibly diminishes, when they are used for feeding; the hull which surrounds them causes a decrease of about one third when removed; but this is far from being a loss. Mr. Sicard has obtained by hulling nearly three bushels (weighing 175 pounds Troy) one hundred and twenty pounds Troy, of clean seed, and forty pounds of hulls. Thus a yield of 145 bushels will divide itself in six thousand two hundred pounds of seed, deprived of their envelope, and two thousand pounds of shells. As this shell is susceptible of assuming an important value, it will be always necessary to remove it from the seed before grinding. The flour obtained would be much whiter. M. Sicard shows the following result from the grinding of 284 bushels, weighing 174 pounds Troy, the seeds not hulled :

Coarse Bran,	-	-	-	-	-	35 pounds.
Middling,	-	-	-	-	-	35 pounds.
Fine Flour,-	-	-	-	-	-	100 pounds.

This flour has a violet hue, very apparent. If bolted with the greatest care, it is made completely white; but as it is raised it forms a dough in which the violet color becomes apparent again. The bread made from it is also tinted with this disagreeable color, nevertheless it digests very well, and is very pleasant to the taste. The flour of the sorgho, mixed with that of wheat, gives a bread of better color, better raised, with a less gummy feeling when broken than pure sorgho, and comparable in every point to the ration (?) bread, the color of which it very much resembles, a fact which will militate against it, by reason of the habit the public have of according to bread excellence in proportion to its whiteness. Generally speaking, this is entirely wrong,

* Thus Mr. Wray gives 8750 pounds, Troy, of seed from 195,000 pounds of cane. In Georgia, United States, they have likewise obtained a product of 8750 pounds; Mr. Hardy, six thousand seven hundred from two hundred and twenty thousand pounds; Mr. Sicard, eight thousand two hundred from one hundred and sixty thousand pounds; M. Itier, 8,838 pounds from 114,000; M. Turel, nine thousand three hundred pounds of seed; M. Hetet, nineteen thousand pounds from eighty thousand pounds; M. Vallarino, twenty four thousand from 264,000 pounds.

and the bread from coarse flour, (which appears inferior to the inhabitants of cities,) is in fact the most nutritious and the most healthy that can be used.

But the real use of the seed of the sorgho is not for bread-making ; it should be consumed upon the farm, in the form of soups and broths, for the men, or used for fattening cattle. We repeat it, that this plan may become really profitable, it is necessary that all that part which is not alcohol, sugar, or dye-stuff, should remain and be returned to the land, by being used for food and otherwise. The cultivator will ultimately hull his seed and sell the product, which will prove a considerable source of profit. As to all these experiments of mixing the flours, they have no value. They only indicate the real embarrassment—a miserable condition. Once for all, let us understand then, well, that all inferior food, (and the varieties of food of which we are treating are inferior, since we make an effort to have them pass into use under the cover of a richer species of food,) should only be consumed indirectly, after having been transformed by cattle into meat, milk, and cheese. It is well to invent a thousand ingenious artifices, but the result obtained will only be in proportion to the matters experimented upon ; and it will never result, by adding to the flour of wheat a third of the flour of barley or of sorgho, that we will have the value of a pure flour. Bread made from wheat and barley, from wheat and rye, is not certainly bad, but it is not of the same degree of excellence as that from wheat alone. The richness of a food does not depend entirely upon its composition of azotized matters or fatty matters. It depends also upon the proportion in which these principles are found associated. For example, every one knows that the great difficulty in the formation of a food for stock, resides not only in the choice of the ingredients which should enter into it, but especially upon the quantity of the different elements introduced. But nature prepares this association in a manner the most judicious, and according to the laws which, although little known, are not the less admirable. If then, we break this harmony of the proportions of the ingredients of food, we do not do less than destroy a portion of its nutritive power. The flour of the sorgho should be given to cattle both cooked and while still warm. Care must be taken not to feed the seed when rudely broken and cooked

afterwards, for the dying principle of the hulls has the property of coloring the bones of the animal, as has been proved by M. de Beau-regard.

Reserving for the end what we have to say about the dye stuffs from the hulls of the sorgho seed, we will now pass to the consideration of the extraction of the sweet juice from its stalk.

We will speak in the first place of the process of M. de Lacoste, by which small cultivators can make use of their canes for preparing the molasses necessary for household uses. The stalks being gathered, they are cut into small pieces, put to boil in a moderate quantity of water, until they arrive at the consistence of marmalade. The juice is extracted by pressure, then put back upon the fire, and clarified by milk of lime, or better, by powdered lime, using about 660 grains to the kilogramme of juice; then the defecation is finished by using the whites of eggs. This syrup, thus treated, is put for keeping in earthen pots, in a place which is neither moist nor warm. This easy and simple process is especially valuable to small operators; when it is proposed to act upon a large scale, such means are necessarily very insufficient. In the United States, a planter of Georgia has obtained an average of 407 gallons of syrup to the acre (say 4617 litres to the hectare). He estimates that the price of manufacture should not exceed 10 to 15 cents a gallon, (54 to 81 centimes, for 4½ litres,) say 11f. 88c. to 17f. 82c. the hectolitre of syrup.*

The extraction of the sweet juice of the sorgho has for its end the transformation into sugar and alcohol. We will not occupy ourselves at this time with the detail of the method for extracting juice after it has been treated of in our other book, the "Guide to the Cultivator of the sorgho." At the time of writing that, however, we had not sufficiently conclusive facts to base a preference for either the one or the other processes mentioned. Now it is quite different, and it is with a conscientiousness that we offer the *maceration* as much preferable to all other systems in use. We will not enter into the details of this operation. The limits of this little work prohibit it, and besides they are mentioned in numerous works upon distillation. It will suffice merely to present the most important points.

* Hunt's Merchants' Magazine, Nov. 1856.

Before submitting the canes to maceration, it is necessary to prepare them. They are readily broken and then submitted to the action of stalk-crushers, which increase their state of division, and tear apart the fibers containing the sweet juice. Then the latter is carried to the maceration vat. We recommend for this operation the employment of the dregs, that is to say, of the liquid remaining after the distillation of the juice previously treated. By this particular method, almost all the saline matters *and the* (?) immediate principles, fix themselves in the residue, which increase the elementary richness, at the same time that the acids contained in the dregs acting upon the bruised canes, facilitate the displacement of their sweet juice. Finally, an economy of water is made which is insignificant in consideration; but what merits more attention is, that we have no longer to fear the influence of waters charged with sulphate of lime, so destructive to fermentation.

The residues arising from the system of Champannois. (maceration with the use of dregs,) are most precious for agriculture, and much preferable to the bagasse of the mills, containing more of sugar, it is true, but less of salts and of fatty matters, and besides being more woody. With maceration, the fibers by the action of heat and acid, cause the commencement of a change which renders them more assimilable for cattle. The residues may be used by mixing them with dry forage and leaving them for a day, or a day and half, in a tub, until a slight fermentation is commenced, which flavors the mass. We have thus a very agreeable forage for cattle, and particularly excellent for fattening stock. To complete our remarks upon the extraction of the juice of the sorgho, we will say a few words concerning the process of F. Bourdais, an intelligent distiller from Algeria. He allows the panicles to remain upon the stalks, and causes the entire plants to pass under the cylinders of his mill, and then submits them all to maceration. The action of warm water then determining the transformation into sugar of the starch contained in the seed, he is enabled to make it of use for the production of alcohol, and by a single operation, at the same time that he economizes the cutting of the tufts, the stripping, moving, carting, and the trouble of the preparation of a certain quantity of malt to assist in fermentation.

CHAPTER III.

DISTILLATION.

THE sweet juice or vesou being obtained, we propose now to give directions for transforming it into alcohol. Under the head of distillation, we will remark, at first, that this operation is divided into two separate ones, entirely characteristic the one from the other, although closely united, namely, fermentation and distillation. From habit, the first is commonly considered as a very secondary matter, as spontaneously rising without need of much care, whilst in reality it demands close attention, and it is only upon its being well conducted that the success and the profit of the whole speculation depends. We may be very certain that a bad process of fermentation will never give an excellent result, however much may be the perfection of the apparatus made use of for the manufacture. In all matters, the end is commensurate with its antecedents, and a fault is much more grave as it is committed nearer to the beginning of a process.

Thus we have fermentation, having for its end the transformation into alcohol of the saccharine matter; the second distillation having for its end the extraction and concentration of the alcohol. A good fermentation demands as its first conditions: 1st. That it should be rapidly accomplished, providing that we avoid the ill effects of an injurious precipitancy. 2d. That it may be continued in such a way that the distillation can proceed with uniformity. 3d. That the juice shall not be too dense nor too watery. 4th. That the liquid possesses sufficient heat, but we must strictly guard against such conditions as will produce a too great elevation of temperature. We will remark here, that the danger of acetification of the juice increasing with the fermentation more rapid, we should in this case make use of quite shallow vats, with a large surface, with which a minimum of heat is necessary to accomplish the conversion of the sugar into alcohol. As to what concerns the particular dispositions for the process of the operation, they should be necessarily subordinate to the fundamental rules

which we have laid down, and never to depart from the perfection of detail which is suggested by practice.

The ferment to make use of admits of certain discrimination ; for, although it may be proved that the juice of the sorgho maintains its fermentable principles in itself, as its action is too weak, it is indispensable to hasten it by artificial means. Brewers' yeast, which is made use of commonly, has the fault of often giving a bad taste to the products arising from distillation, an effect which is lessened, it is true, by a continuous system ; but the juice of the sorgho, as we learn from M. Pezery, reproduces a large quantity of yellowish ferment, presenting a great analogy to the yeast of beer in the form of its globules, and possessing also the same stimulating properties. Here, then, we have a ferment already to our hand, which may be made use of, not only for its legitimate end, but the surplus of which can be profitably used by bakers. We cannot conclude our notice of the matters which relate to the fermentation, without saying a word upon the use of sulphuric acid. It is well understood to-day, that the addition of this acid in the proportion of one half thousandth part to one and a half thousandth parts, favors the transformation of the sugar into glucose,* and prevents the viscous fermentation. This last property should be taken into consideration, when, at the end of the season, we have upon our hands only canes which are more or less damaged, one is obliged to operate upon juices of which the fermentation is irregular, and sometimes causes very prejudicial accidents. Finally, experience has proved that the residues of fermentation, where the sulphuric acid is employed, are more profitable for cattle. Let us remark further, with M. Beaudement,† that all fermentation cannot be carried on without acid or its equivalent ; if it is not put in, it forms itself at the expense of the sugar and of the alcohol ; and so positive is this, that the fermentations made without the addition of acid are more acid at the end than those where it has been added. The sugar of the juice having been changed into alcohol, it is neces-

* M. Du Bronfaut, who since 1825 has known this influence, apprises us also that the acids have a favorable action upon the reproduction of an energetic yeast, capable of being used in the other fermentations of juices.

† Report upon the Beet Distilleries, 1855 and 1856, made to a Commission of the Society of Agriculture, by M. Beaudement, p. 58.

sary then to extract the product by means of a distilling apparatus. Here presents itself the important question of the choice of an apparatus. We acknowledge our great perplexity in resolving this question, being quite ready to acknowledge that we do not know the apparatus answering to all the exigencies of the manufacture upon the farm; but, however, we will say, procure a simple apparatus, economising fuel, accomplishing much, and at a relatively low price. Avoid, by all means, too great cheapness. It is often accompanied by very grave evils, which reveal themselves without any room for improvement, at the most critical time. All things being equal, and taking into account the particular situation of a distillery next to a farm, it is much better to spend a little more, and have a good useful apparatus.

Manufacturing industry may find in the collection of Messrs. Derosne, Du Bronfaut, &c., a most perfect apparatus, but rural industry, perhaps, will not admit of the employment of such perfect instruments. They require more simplicity, even although the yield may be less complete. It is but a short time since much attention has been paid to this rural distillation, and consequently all the details of this interesting manufacture cannot be considered perfect; the success which the Champonnois system has attained is a result significant of an attractive future. We do not hesitate to mention to farmers, as the most perfect system at present used, since it embraces all the conditions which we have previously used as the fundamental principles of a good distillation. It is especially in the extraction of the juicy maceration with the dregs, and in fermentation, that the superiority of the Champannois system appears. As to distillation, which is done with the apparatus of Cellier Blumenthal, perfected by Derosne, it is far from having been carried to that state of perfection of which it is capable.

We will proceed to notice certain other details bearing upon the products of the distillation of the sugar sorgho, their rectification, and use; but this will only be a consideration of comparatively slight value, since it will not be based upon other than very limited facts; and, besides, we have mentioned this subject at length in our "Guide to the Cultivation of the Sorgho."

Before passing to the economic part of our subject, we will speak of some special products furnished by the sugar sorgho. The researches of many intelligent observers have evinced in this plant certain coloring principles, susceptible of acquiring a certain importance that is very likely, so far as regards the hull of the seed; but as to the stalk, it is not possible to hope it having a good result in practice. But in advancing this opinion we hope that we will not be understood as being hypercritical upon the scientific laborers who, analyzing matter, have extracted from it its most hidden secrets; thus again proving that man, thanks to the sources of his intelligence, finds in everything a part worthy of his attention, and that he has only to interrogate to obtain all he needs; that, in a word, there is nothing in the whole realm of nature which is entirely without value. We may repeat the preceding remarks in considering the cerosie, a waxy efflorescence which is met with upon some large cereals, the obtainment of which is not more possible in the case of the sorgho than with the sugar cane; nevertheless, it is a substance which merits being studied, and it is necessary to know it more intimately to follow it through the different elaborations which it undergoes in the saccharine stalk.

EXPENSES AND PROFITS OF THE INDUSTRIAL CULTURE OF THE SORGHO.

In the following table we have not the pretension to fix in a peremptory manner, a result which the sorgho may give under all circumstances. We wish only to present the probable results of a good culture, with a soil suitable to its growth, and endowed with certain fertility.

RAW PRODUCT.

1. Sixteen thousand pounds of stalks, which, treated by maceration, will yield at least seventeen gallons of juice to two hundred and seventy pounds, say ten thousand three hundred gallons of juice, susceptible of giving eight per cent. of alcohol (in the south of France and in Algeria; seven and six per cent. in our central departments) upon distillation. This, then, is a yield of about eight hundred

THE SUGAR SORGHO.

291

and twenty gallons of alcohol, at the price of about seventy-five cents per gallon - - - - -	\$625
2. Thirty-two thousand pounds of leaves, furnishing a very excellent green forage, at two francs a quintal, -	48
3. Eighty thousand to ninety-five thousand pounds of the residue after maceration, at one franc fifty centimes the quintal, about - - - - -	95
4. Seed, one hundred and seventy-four pounds. Three thousand nine hundred pounds of hulled seed at twenty-five francs the hundred kilogrammes, - - - - -	74
One thousand two hundred and sixty pounds of hulls for dyeing, at fifteen francs the hundred kilogrammes, - -	14
Total, - - - - -	<u>\$856</u>

EXPENSES.

1. Cost of good culture, with manure and irrigation, comprising the cost of gathering, of cartage to the manufactory, about one hundred dollars to one hundred and forty dollars, average - - - - -	\$120
2. Cost of distillation and rectification, at six dollars to the twenty-six gallons, - - - - -	187
3. Hulling the seed, at the price of about twenty cents per bushel, - - - - -	18
Total, - - - - -	<u>\$325</u>
Raw product, - - - - -	\$856
Expenses, - - - - -	<u>325</u>
Net profit, - - - - -	\$531

Now if, in place of putting twenty dollars, or about seventy-five cents per gallon, as the price of the alcohol, we take its actual value in our market, that is to say, \$1 05 to \$1 12, that is at once an increase of the profit of not less than \$240. Admitting that the price of alcohol may descend to \$12 in a few years, still the industrial manufacture of it by the farmer will bring in a net profit per acre of about \$111.

One is tempted, in view of these figures, to think it a species of

exaggeration ; but, after all, do we not see the distillery of the sugar beet give \$400 to \$600 per two and a half acres ? How, then, should it be a matter of surprise that the sorgho, much more rich in saccharine principles, and which, besides, produces seed, should give a profit much more considerable ? The inevitable conclusion then is, that we must expect a very considerable reduction in the value of alcohol.

As to a yield in forage, we will say that M. Nivière has obtained to an acre, (in the department of L'Ain,) 80 quintals dried sorgho fodder, at \$1, worth \$80. This is a magnificent result, and we doubt it will be duplicated in the most of cases.

CONCLUSION.—When a culture like that of the sugar sorgho, implanting itself in a country, commences to be really popularized, the question is immediately agitated what influence it may exercise upon the agriculture of that country ; if it furnishes products of a commercial character. The question is mooted if it takes more than it leaves, that is to say, makes other cultures tributary to itself, at the same time particular consideration should be given to the state of the district where it must localize itself.

We have already sufficiently established that the sorgho leaves in the farm the greatest and most valuable portion of itself, since it is only the carbonaceous matters which are exported for manufacture. It remains to show in what manner it will influence the agriculture of the south of France.

From the progressive tendencies, and the great popularity which the sorgho is destined to acquire, we may affirm in advance that the inhabitants will make a considerable sacrifice for its culture. It is probable that much attention will be given to obtaining residues from the distillery, the most suitable for feeding stock. Cows supplied with this forage, and especially with the green sorgho, will be better milkers and more able to bring up their young ; and this cannot be without its notable influence upon the gradual improvement of their stock. The farmers will find themselves supplied with a very prolific and excellent substitute for the pasture-fields and meadows. These suppositions may appear measurably problematical ; but look at them in what light we may, we cannot be blind to the fact that the sorgho is destined to exercise a certain reaction, which, under the influence of favoring circumstances, will eventuate in much good.

The exigencies of the case will demand the establishment of suitable distilleries organized upon the plan of those already existing in the southern departments. We are happy to be able to announce that projects of this kind are already in process of execution, and that a large company has been formed whose operations would be as profitable as they are vast.

A further advantage of the Chinese Sugar Cane, which it is only needful for us to make generally understood, is that it will cause the distillation of wines to completely disappear. Sorgho alcohol once coming into use, there will be no longer any reason for burning inferior wines, but rather they will necessarily be driven to improving them, before being able to make them enter into general consumption. To conclude our work, we call attention to the great effects which the sugar sorgho is destined to produce in all countries where it is propagated, not only in France, Algeria, Lombardy, Tuscany, but still in Russia for its southern provinces; and in the United States it is a question whether this precious plant may not replace the sugar cane. One of the large planters of Alabama, Dr. Terrill, is making this year a plantation of some twenty acres. The future presented by the sorgho is a vast one. Its influence upon our agriculture is marked, and the efforts of this general company for manufacturing the sorgho will have a great influence upon the success of the sorgho, and at the same time we may say upon the progress of southern agriculture, so backward until now, causing it to become, if not the first of our country, at least one of the most rich and flourishing.

ALCOHOLIZATION OF THE STALKS OF INDIAN CORN AND THE SUGAR SORGHO.

BY DURST, CHEMIST, PARIS, 1857.

* * * * *

THE plant known under the name of sorgho, has been cultivated for a long time in France, but is not designated under that name in the west. It has been known under the name of broom corn, and under the name of millet, in Gascony and the department of Landes. In the early stages of growth, our indigenous sorgho differs very little from corn; has the same appearance, same leaf, same rapidity of growth. In proportion as the plant grows, the peculiar appearance of each is manifested. The leaves of the sorgho are less developed, its stalks more hardy, more woody, grow to a greater height, whilst those of the corn, more tender and full, preserve the appearance of the sugar cane. This circumstance, which is met equally in the new sugar sorgho, causes us to think that it would be without doubt preferable to corn for the manufacture of sugar, because its juice should contain less mucilage. Every one knows that this vegetable product is injurious in the manufacture of sugar. The following article upon the sugar sorgho we find in the journal *L'utile et l'agréable*, for the month of April, 1855 :

“The sugar sorgho (*holcus saccharatus*) has been introduced into France by M. Montigny, who has brought this plant from China, where it is cultivated like grain. It is there designated under the name of sugar cane of the north of China. The Chinese Tartars make great use of it. At the great exposition of Moscow, in 1852, some of the stalks of this kind of sorgho were exhibited under the title *Précieux Gaoutlam de la Chine graminé*. Various experiments in the cultivation of this plant have been made in several of our departments, from which it has been proved that it ripens perfectly in the south of France.

“A report of the Agricultural Assembly of Toulon, to the Minister of War, has communicated curious details upon the sugar sorgho in respect to the agricultural industry, and to the manufacture of sorgho,

and also of distillation. The different experiments made in *Le Var* have given very important practical results, proving that the *vesou* or juice obtained from the sorgho is endowed with an alcoholic richness much superior to that of all other substitutes for the vine.

“The sugar beet contains 8 to 10 per cent. of saccharine matter. The sorgho, as has been proved by the experiments at Verrières, by M. Vilmorin, have given 16 to 20 per cent., from which can be obtained 8 to 10 litres of pure alcohol, appropriate for all industrial and domestic use; and as this precious cereal, an excellent nourishment for the stock, which eat it greedily, develops itself with extreme rapidity, the same where irrigation is rare and difficult, it will be readily understood that this is destined to play an important part in our cultivations, and especially in those of Algeria. M. Turrel, the author of the report, says that in accepting for France the yield obtained at Verrières by M. Vilmorin, with the sorgho cultivated on his estate, we would have the following result. The sorgho furnishes at a minimum of 50 per cent. weight of its stalks in sweet juice. As a minimum yield, calculated according to the result at Verrières, would be about 30,000 kilogrammes to the hectare. From it could be extracted at least 21 hectolitres of alcohol of a value of 3,780 francs, which would give to the hectare a yield that no other agricultural product can hope to equal. Let us add, that the yield in Provence and in Algeria would be probably more considerable than that obtained at Verrières. M. Vilmorin notices a remarkable superiority of the sorgho: the purity of its juice is such that brandies of the first quality coming from it are sufficiently pure to be directly put into manufacture. M. De Beauregard, in a recent report to the Assembly of Toulon, has shown that having distilled the juice of the sorgho fermented by the assistance of the grape stems, or of the bagasse of the cane itself, he has obtained an alcohol of excellent flavor, which has been sold in the Marseilles market at the ordinary price of other alcohols (200 francs the hectolitre of 316). Several cultivators, of Haute Marne are also undertaking the extensive culture of the sorgho. One of them, M. Ponsard, has made for three years experiments upon this plant. ‘From it,’ says he, ‘I have arrived at the conviction that the *holcus saccharatus* cannot in the climate of Paris be cultivated on a large scale for manufacture. It will have an enormous yield as

a forage, but as a sugar plant it will only be very lucrative at the south. This has been well understood by the seedsmen of Paris, who have sowed in Provence their stocks of seed for sale. This plant is very prolific in seed. It is probable that in a very little time it will be sold at as low a price as that of the common sorghos. Of an easy culture and extraordinary hardiness; considerable yield in three different respects, seed, forage, and sugar; these are the advantages presented by this plant.

"Its syrup is without any unpleasant taste; its alcohol very pure, and without a trace of empyreumatic oils, so abundant in the alcohol of the beet. The fermented juice makes a very agreeable drink. M. Vilmorin has made of it a cider quite analogous to the cider from apples. He has mixed with it, in variable quantities, various other ciders and drinks made from fruits, and always with a decided advantage.

"From the necessity of not covering the seed of this plant too deep, in order to facilitate the germination, the sowings should be made on a hot-bed, to preserve them from the birds, and other thieving animals."*

M. Ponsard adds: "It is to be hoped, and I am shortly expecting this result to happen, that the cultivation in the climate of Paris will render this plant more precocious, and that some varieties will be discovered which will perfectly ripen their seed in this latitude. Under these conditions, the *holcus saccharatus* will take its appropriate and important position. From the cultivation of a small plot of this seed, a person could have seeds for his poultry, forage for his cow, and an agreeable and abundant drink for himself."

We will mention, in concluding our remarks concerning the trials of the cultivation of the sorgho, which have been made at Hyères by M. Rautonnet: "The plant, in ordinary conditions, has furnished 30,000 kilogrammes of juice to the hectare—a yield which exceeds that of the beet. One stalk, of 450 grammes, gives 150 grammes of juice, containing 10 to 15 per cent. of sugar."

* We do not agree with M. Bensart, that the culture of the sorgho, which is entirely like that of broom corn, should be protected in the same manner. The transplanting of it will injure its ulterior development. To preserve the seed against birds, it is much better to watch the crops, as is the custom with other seeds, until the plant comes out of the ground and has acquired sufficient strength to defend itself against their voracity. To expedite this matter, the seed may be steeped before sowing.

Before going further, it appears to us useful to compare the different sugar-bearing vegetables, to glance at their yield of sugar.

- | | | | |
|---|-----------|----|-----------|
| 1. The sugar cane gives, by the old process | - | 14 | per cent. |
| By the new apparatus, perfected by Derosne | | | |
| & Kyle | - - - - - | 20 | " |
| 2. The sorgho cultivated in the South | - - - - - | 20 | " |
| 3. Maple tree | - - - - - | 4 | " |
| 4. The beet | - - - - - | 10 | " |
| But, in practice, obtain only | - - - - - | 6 | " |
| 5. The Jerusalem artichoke, from 15 to 16 per cent. | - - - - - | 15 | " |
| 6. Corn cultivated at Paris | - - - - - | 10 | " |
| 7. Corn cultivated at New Orleans | - - - - - | 17 | " |

If this last figure is reliable, which we do not greatly doubt, the corn cultivated in the south of France will give a result almost equivalent. It will be understood that their conditions of growth are similar in the corn as in the sorgho. In rainy seasons, a juice containing more of water, should, by that very fact, contain a less proportion of sugar ; which explains the remarkable differences between the analysis made by different experimenters. Here, then, we are in possession of two plants equally interesting and equally productive of sugar ; for there exists between them some differences upon the score of yield. This would only be matter of greater or less quantity ; but their expressed juices are, chemically, the same. These two varieties have between them a relationship so similar, that it should not be an astonishing matter to see them giving similar products. We have seen, in the article extracted from the journal, *L'utile et l'Agreeable*, that M. Vilmorin has made with the fermented juice of the sugar sorgho a cider of good quality. The fermented liquor of corn would be quite similar to it. What confirms this fact is, that in Chili, and in a part of South America, according to the saying of travelers, they make with the stalk of maize a species of fermented liquor called *chica*, which has, they say, the appearance and taste of a real cider from apples. They add, that it is in common use in the households ; and that, distilled, it furnishes a brandy very agreeable, which has quite a similarity to rum. With these facts before us, then, we advise

the reader, that in the following considerations we will not distinguish between the two plants in all that respects the time of their maturity, their leafing, the grating of their stalks, the pressure of the pulp, and the use of the residues. They should be treated in the same manner throughout. And seeing all the good that is said of the sugar sorgho and the articles published in its praise, we do not understand why maize is passed by unnoticed. Is this a matter of speculation, or a furor for a new product, such as is produced every day with all new things. We are ignorant on the subject. We are far from dissuading agriculturists from undertaking the cultivation of the sugar sorgho. We are much pleased, on the contrary, to give it a decided support, and we place it in the first rank among our recent agricultural acquisitions; but these advantages should not hinder us from rendering to each other product, of a similar nature, the justice which is their due. While awaiting, then, the generalization of the culture of the sorgho in our southern provinces, we beg that the cultivators will distil the stalks of the corn. Besides the product in brandy, they will find in the residue the means of increasing the food for their stock, in a country where it is generally scarce and dear. Let proper attention be given to both maize and the sugar sorgho; the results will be about the same. The capital point to obtain complete success is to seize the exact favorable moment for gathering the stalks. If too soon, the plant contains too much mucilage and gum; if too late, the seed has consumed part of the sugar contained in the stalk; at least, it is so in the maize.

It is probable that, at a subsequent day, there will be erected in the southern districts manufactories for treating the sugar sorgho, which we believe fully to be more appropriate for the manufacture of sugar than corn, because we judge that its juice contains less of mucilage and gum.* The yield of the sugar sorgho being equal to

* Our author has here made a very important distinction between the maize and the sorgho. The sugar of the corn, after the ripening of the seed, is very rapidly and considerably reduced; but with the sorgho, if we may judge from the experiments made in Algiers by M. Hardy, not only does it not lose in its proportion of sugar by standing in the field after it has attained a complete maturity, but, if the tufts be cut off, the juice will actually show on the saccharometer a perceptible increase in strength.—H. S. O.

that of the sugar cane, the planters of the south can, with profit, compete against the sugars from the beets and from the colonies. Undertakings of this sort would give very large profits, doubtless. Not only is the sugar sorgho more rich than the beet, but it ripens much more rapidly than the sugar cane. The agreeable use that can be made of the molasses and the pulps of this plant, place it, in this regard, in a position unequalled by others.

What we have said concerning the erection of manufactories of sugar in the south of France for working up the crops of sugar sorgho, should be considered more as a hope than as a prophecy to be immediately realized. In these unenlightened districts, ingenious ideas applied to agriculture are so scarce that we have but small hope of a speedy realization of enterprises such as these. * * * *

EXTRACTION OF THE JUICE OF THE MAIZE AND OF THE SUGAR SORGHO.

To extract juice of sugar bearing plants, there is, independent of the pressure of which we have already spoken, an expeditious process. This is maceration. This system has been applied with success in the manufacture from the beet. It has been found that those treated thus are purer, ferment better, and suffer less change than when they are obtained by prolonged pressure. Independent of regularity, which is the distinct property of maceration, the treatment of beets by this method is an excellent one in more ways than one. On the one hand, the acidulated liquid boiling increases the sugar in the beets, saccharifying them. On the other hand, it raises the temperature of the juice, and disposes them to undergo a good fermentation. Maceration, then, is particularly advantageous and applicable to the beet distilleries, nearly all of which are in operation at the North, and at work on the coldest days of the year. But it is entirely different with the maize and the sorgho, as to distillation. Being accomplished at the South, and oftentimes with the greatest heat of weather, the warming of the juice is not necessary, any more than saccharification. The sugar being entirely formed in these plants, maceration in cold water would have the effect of weakening these juices. It is just upon these points of consideration that the press is preferable for it, because they yield then the sweetest and densest juices. In this condition they present

less obstacle to fermentation and distillation ; although, it may be known that the more sugar is dissolved in water, the more prompt and complete is its conversion into alcohol, nevertheless, this absence of water can be compensated for by a temperature more elevated, with the addition of an increase of ferment. As the still retorts already in operation in the vine districts operate mildly, and as we do not wish to change them, it is much preferable, it will be understood, to distil the juices fermented at ten to twelve degrees of the saccharometer, than liquors of five to six degrees, like those of the beet, obtained by maceration.

FERMENTATION.

The juice of the sugar sorgho contains truly its ferment in but small quantity. It is well, then, to add to it, and even to force the quantity to operate with more rapidity. This celerity is especially necessary when the liquor is destined to be put to immediate distillation. It would be quite the contrary, though, if this kind of cider is desired to be preserved for a long time. The quantity of the fresh yeast of beer to use, is about 500 grammes to the hectolitre of juice in fermentation.

In those districts far removed from the cities, it will often be difficult to procure the yeast of beer fresh enough, because the brewers are very scarce. To obviate this inconvenience, which may present itself in spite of all possible precautions, we propose to replace it with the lees of wine, red or white, pressed and putrified a little, that may be dissolved in the juice in the same proportion as would be the yeast. It is well to notice that white lees have less action than red ones, and that, consequently, there would be needed a greater quantity of those to produce the same effect. Yeast, when it can be procured, should be preserved in a cool place until the moment of using it ; otherwise it will pass into putrefaction, and will no longer be good for use.

The fermentation of the juice may be sufficiently well done in the great tuns used for wine in distilling districts. It is well to remark that fermentation is accomplished more readily and completely in vessels of great capacity, than in those which are smaller. A more elevated temperature is also necessary for this latter. However, in the absence of the first, we may make use of the second, but it is necessary to practice the method employed for wiaes destined for the boiler.

These wines are fermented naturally, and without the use of dregs, in the large vats, which are partially filled. This process presents two advantages: the first is escaping the loss of the liquid, which wastes nothing at the bung during the tumultuous fermentation; the second is rendering the fermentation more prompt, by reason of the sweet liquid being found in contact with a larger mass of air. This circumstance is very important for the production of alcohol. Every one knows that if wine preserves its sweetness at the moment of introducing it in the still retort, there is a loss for the distiller. This circumstance indicates that all the sugar is not decomposed, that is to say, not converted into alcohol. When the tumultuous fermentation is terminated, it is not proposed to distil the liquor immediately; it may be drawn from the tuns and transferred into the casks, in order to escape the evaporation which would take place in large vessels but partially closed.

FERMENTING HOUSES.

We will say but little upon these fermenting rooms. Their temperature should be maintained at about twenty-five to thirty degrees. In the summer it would be well to take certain precautions not to suffer this to be exceeded. For this purpose, it will be well to open the doors and windows during the night, and closing them at an early hour in the morning. In order to maintain the fermenting room at a constant temperature, it should not be entered except when absolutely necessary, and kept tightly closed. It is well understood that all we say here only applies to distilling practice in the summer time, upon the maize and sugar sorgho, intended to be fed to cattle afterwards, of which the juice are extracted previously to make them ferment and distil. This manufacture, beginning in the month of June, should continue throughout the months of July, August and September, and be completed about the end of October.

As to the distillation of the maize and the sugar sorgho, from which the seed is removed, as it is done in the fall, it will be no longer necessary to guard against an excessive temperature. It may be useful in certain cases to warm the place artificially, and even to warm the juice.

To avoid the constant purchase of new quantities of beer yeast, it would be well to fit against the vats some box or receptacle in such a way that the ferment which escapes from the bung-hole can be received in the vessel placed below it. This ferment will do for subsequent fermentations, in place of wine lees or beer yeast. On the same principle, the ferment which floats on the surface, in the large vats, may be employed; and the whole of this should be kept in a cellar until the moment of using them. When it is thought proper to wash the pulps, or *parenchymas*, in place of pure water, *vinasse*, or others, should be employed, and then the pulps should be again put in press. These wines, and those cooled containing their ferment, will permit of diminishing by so much as the quantity is judged necessary for a good fermentation. To warm the juice of the maize and of the sugar sorgho when it is judged necessary, a large cauldron will be suitable, such a one as is frequently found on estates. In the opposite case, the cauldron which is used for distilling wines would be made use of, always taking, however, the precaution of making it perfectly clean before using it.

In place of selling the ciders of the sorgho manufactured for the still retort, to professional distilleries, it will be much more profitable for the planters to distil it themselves. We recommend, then, all who shall undertake this industry, to purchase apparatus of the kind we notice in another place. This practice is much preferable to that in use at the South. There the planter is obliged to take care of his wines, and experience the loss resulting from the presses up to the very moment of giving them to the distiller. Furthermore, the costs of transportation, even to the distillery, are to be met by him, all of which diminish by so much his profits. The prices of the proper stills are quite moderate, and they give excellent yields of brandy. As they are not at all complicated, or liable to get out of order, the most ordinary hands will usually be able to conduct them after a few days' practice.

The method which we have adopted for the distilling of the sorgho is so simple, that we really believe that its general adoption presents but very slight difficulty. Each one can, with our work in his hand, undertake this industry. A reference to the list of utensils indis-

pensable for the work, will show to our readers that the expenses to be met are really insignificant.

List of Apparatus necessary for the Distillation of the Sorgho, in those countries where the Still Retorts are already in operation.

1. A rasping mill, such as is used in the sugar beet factories, but supplied with stronger teeth, because of the stalks of the sorgho being harder	- - - - -	\$50 00
2. A centigrade thermometer	- - - - -	60
3. A saccharometer	- - - - -	70
4. An alcohol meter	- - - - -	70
		<hr/>
	About - - - - -	\$52 00

Thus the principal expense will be confined to the rasping mill, of which the price is moderate, and within the reach of almost every one. For small cultivators, a mill at the price of thirty dollars to thirty-two dollars will be sufficient.

Agricultural Distilleries.

The still retorts, with which the cognac brandies are made, are, with trifling alterations, those which have been used for a hundred years past. They consume much fuel, and perform their work very slowly. Still, in spite of these defects, it must be that they offer, in practice, a real superiority as to the qualities of the brandies, since the merchants, the supreme judges in these matters, continue to prefer the products of these still retorts to those of more perfect apparatus. What contributes to maintain and perpetuate the existence of these alembics in the vine districts, is their simplicity and their low price—advantages which cover up all their defects. Thus, to these two circumstances, the distillation has taken a wide range in the departments of which we speak. There is scarcely a single small operator making 50 to 60 casks of wine who does not purchase a little still, with which he converts his wine into brandy. These circumstances have urged us

to advise their general adoption; but to do away with a portion of the inconvenience attendant upon their use, we have caused the apparatus to undergo an improvement which, without making them lose anything of their primitive simplicity, procures two important results—an economy, more or less, of fuel; and a double production of brandy in the same space of time. By this new plan our still gives brandy of 20° to 22° of the first quality, while the old way only gives these results after two successive distillations of the same product. The capacity of the apparatus is thus doubled, by an expense which does not exceed two hundred francs on an average.

Expense attending the purchase and erection of an Improved Agricultural Distillery.

1. A cucurbite, or copper cauldron, containing 80 gallons, about - - - - -	\$92 00
2. A copper wine heater, of the same capacity - - -	14 00
3. A copper condenser, of 150 quarts - - - - -	54 00
4. A wooden cooler, bound with iron - - - - -	12 00
5. A copper worm - - - - -	40 00
6. A little pump, to introduce the fermented juice into the cauldron - - - - -	8 00
7. A rasping mill and its apparatus - - - - -	50 00
8. Cost of erection - - - - -	20 00
Total - - - - -	<u>\$290 00</u>

With this apparatus, which should operate night and day, according to established custom, three heatings a day of twenty-four hours would be made, and about 240 gallons of liquid distilled; but, as our maize and sorgho wines contain double the alcohol as those of the beet, it is about 475 to 500 gallons that would be worked up in this lapse of time. This quantity of fermented juice would give about 16 per cent. of sugar; an average for the sorgho of about 38 gallons of brandy, at 50 degrees centesimal; and for corn, about 12 per cent., about 30 gallons of brandy of the same quality.

For the Distillation of 2,500 lbs. of Sorgho Stalks, per day of twenty-four hours.

To gather the stalks, cleanse them, rasp them, press them, ferment the juice, and carry on the retorts, there will be needed an overseer - - - - -	\$0 60
An intelligent workman - - - - -	50
A laboring man - - - - -	40
Two women, at 1½ francs each - - - - -	50
A little boy, 15 or 18 years old - - - - -	30
Interest on the material used, at 10 per cent., calculated on \$400, (the season being about 150 days,) an average, per day - - - - -	20
Wood or coal - - - - -	40
A hectare, (about 2½ acres,) sown in sorgho, should give a minimum of 160,000 lbs. Troy of stripped stalks. We value 2,500 lbs. at - - - - -	4 00
Total expense per day - - - - -	\$6 90

265 lbs. of stripped stalks would give, according as the season had been dry or wet, from 50 to 60 per cent. of juice—that is to say, 130 to 160 gallons, which, added to the water necessary for liquefying the pulps, would carry the quantity of liquid to about 275 gallons, which would furnish 45 gallons of brandy, at 19 degrees of Cartier. This brandy, by reason of its quality, may be estimated at about 55 cents per gallon - - - - -	24 00
Deduct the expenses, \$6 90, profit per day - - - - -	17 10
Multiply by 150 days, the profit during the season - - - - -	\$2565 00

Distillery of Cognac Brandies.

We have mentioned that the distillation of cognac brandies is done with very simple and cheap apparatus. We give here the description

and the price, to afford an idea of what may be done with very little capital.

Cost of Purchase and Erection of the Distilleries in Saintogne and l'Angoumois.

A copper cauldron of about 65 gallons,	\$70 00
A wash heater, of same capacity, of wood bound with iron,	10 00
A copper worm,	30 00
A wooden cooler, bound with iron,	10 00
4 wooden tubs to receive the products of distillation,	10 00
Cost of erection,	10 00
	<hr/>
	\$140 00

With this apparatus, three charges a day of 24 hours can be made, which is about three barrels of 46 gallons. For fuel, only wood or peat can be used. Peat charcoal cannot be used for this purpose, because in burning it throws a very large quantity of heat, and would burn, on the bottom of the cauldron, the leaves, seeds, and other heavy matters which it is the custom to leave in the wine. These foreign matters, precipitated by their specific gravity to the bottom of the still, would be carbonized, and would give to brandy an empyreumatic taste. In spite of the evident imperfection of this apparatus, notwithstanding the time and fuel which they require, they accomplish their work in a satisfactory manner, and give good results—results which are generally appreciated: for all the Cognac brandies are made with an apparatus of this sort. We, however, beg the planters to avoid the use of the wooden wine heater, because of the loss of alcohol which it would evidently suffer to be made by the escape of the steam through the staves. It would be well to replace this with a copper vessel, or at least one of iron, which would be more reasonable in price. With this modification, this apparatus can be employed with profit in the small manufactories. They can distil three hundred barrels of about sixty-five gallons in the space of a season of about five months, or a hundred and fifty days in duration.

Price of an improved distillery for operators on a small scale.

Copper cauldron of about 55 gallons,	-	-	-	\$50 00
Sheet-iron wine heater of the same capacity,	-	-	-	30 00
Copper worm,	-	-	-	30 00
Copper condenser of 14 gallons,	-	-	-	20 00
A small pump,	-	-	-	10 00
A wooden cooler,	-	-	-	10 00
A rasping mill and its apparatus,	-	-	-	40 00
Cost of erection,	-	-	-	30 00
				<hr/>
Total,	-	-	-	\$220 00

Thus for \$200 to \$240, a small distillery could be had, embracing all the advantages of that which we propose in another place, but which would do one third less work, in consequence of the reduced size of the apparatus.

Cider of the Sugar Sorgho, or the Maize, for Consumption and for Commerce.

Those who wish to undertake this manufacture, should give more care to the production of these sorts of cider, in order to give them the property of keeping, equal to that of wine.

Below we give our formula. We can be certain that it will give good results. We suppose the juice at 8, 10, or 12 degrees of density, and the cask of a capacity of about sixty gallons. In this case especially, the operator should be provided with a thermometer and saccharometer, to weigh the juice and to assure himself of their temperature before putting them into fermentation.

RECIPE.

1 kilogramme, 500 grammes (3 pounds) of good pulverised *argols*, (the raw tartar scraped from the cask of either red or white wine); 500

grammes, equal to about 1 lb. of grapes coarsely bruised ; about 2 lbs. 8 oz., Troy, of fresh yeast of beer, or an equal quantity of good wine lees, white or red, a little putrefied. When the lees of wine are used for supporting fermentation, the dose of raw tartar is lessened, and in this case would be reduced one kilogramme, 2 lbs. 8 oz. only.

METHOD OF MANUFACTURE.

Put the tartar and the *rapes* in a hundred quarts of juice, that you carry to the boiling point, (in warm weather it is not necessary to make the juice boil.) After some boilings throw the whole into a receptacle of a capacity of 65 gallons, and finish by filling with cold sorgho juice. Before putting it into the fermentation, let the temperature fall to 25 or 30 degrees centigrade. Assure yourself of the actual degree by the use of the thermometer. The next step is to take from the vessel two or three quarts of liquid, add to it the two and two third pounds Troy, of fresh yeast form a mixture of it and throw it back into the vessel. With a stick stir it all up together.

Some days after the fermentation shall have ceased, it is necessary to draw of the cider, which already will have fermented in the large vat, and place it in the cask, which should be entirely filled.

A month, or two months afterwards, the cider should be sealed up and then drawn off with care to deprive it of its lees. Under such conditions these ciders will be of very excellent quality, and can be preserved like white wines, to which they bear considerable resemblance. Like them they will gain in quality by becoming older.

If it is desired to give these ciders a flavor which they do not have, there may be introduced into the barrel, either before or after the fermentation, two ounces of powdered iris,* to 65 gallons ; or four ounces of elder berries, or some vanilla. Many farmers may possibly find this method of manufacturing cider, complicated and embarrassing. To boil a portion of the juice before putting it into fermentation, seems to them a useless and superfluous thing. However, I insist upon this portion of our recipe, if it is desirable to operate with certainty. We are of the opinion, that the same process should be

* *Fleur de lis*, flag flower.

employed for wines in cool seasons. It is evident that this trouble may be avoided in the summer, because the end which it is proposed to accomplish by carrying the juices to boiling, is to make them ferment at 25 or 30 degrees, the temperature necessary for a good fermentation. This degree, we repeat it, is especially necessary for casks of a small capacity. The larger the vats are made, the less elevated a temperature is necessary. Thus for tuns of a capacity of twenty-five to thirty hectolitres, 14 to 15 degrees would be necessary for a good fermentation.

Recipe for making a very agreeable beer with the juice of the sorgho or of Maize.

The juice is boiled with about one lb. of hops per twenty-five gallons, or ten oz., Troy, according as it is preferred to be more or less bitter. The juices are cooled to 25 or 30 degrees centigrade. Then they are put in contact with the yeast, (as we have mentioned for the cider,) one lb. of quite fresh yeast to the twenty-five gallons.

As soon as the tumultuous fermentation is quiet, the liquid is drawn off, and the second operation is ready to proceed in the same manner as for the cider.

Then it is clarified with gelatine, or the white of an egg, in the ordinary manner.

As will be seen, this process is very simple, and nothing can be more economical. In this manner will be obtained, at a very low price, a fermented drink very healthy and agreeable, which will present the appearance and flavor of the most approved white beers. It suffices simply to add to it a little caramel.

New Process of Fermentation, and preservation to an indefinite time, maturing after several days.

The manufacture of the cider at a low price, with a preservative quality, and that is made by age like wine, will have so important results for the well being and richness of our agricultural public, that we have decided to treat it with all the detail that it is deserving of.

We have already mentioned elsewhere, that the beer manufacturers of Bavaria were in possession of this secret. Chance, aided by the very low and suitable temperature of the climate, seemed to have been the accidental cause of this interesting discovery. Its practical operation is very simple. It consists in carrying on the fermentation of the sweet juice at a temperature of nine or ten degrees centigrade, in shallow vessels with large surface, which are left without any other care than from contact with atmospheric air.

By these processes, beers, ciders, and wines, acquire a great preservative quality. They are not at all affected with the variations of the temperature; and what is remarkable, they are as perfect some weeks after fermentation as if they were two or three years old.

To thoroughly comprehend upon what law these good results depend, it is indispensable to know the phenomena which occur in the alcoholic and acetic fermentations. The ferments, which are the producers of the fermentations, are azotized substances, in condition to unite with oxygen, for which they possess a great affinity. They have, furthermore, the faculty of transmitting the action with which they are endowed, that is to say, the fermentation, to the sweet alcoholic liquids with which they are placed in contact; but the degrees of temperature necessary for these transformations are not the same for these two different fluids. The degree the most favorable for the conversion of the alcohol into acetic acid (vinegar), by means of a ferment, lies between twenty-five and thirty degrees of centigrade; at nine and ten it loses completely this faculty, and it is no longer in action upon the alcohol. On the contrary, the oxidation of the ferment at this low temperature, does not experience any obstacle—not more than that of the sweet liquid to which it imparts its action, converting it into alcohol by means of oxidation or fermentation.

Let us now apply this principle, deduced from the attentive observation of facts, to the manufacture of wines, as it is practiced. As soon as the expressed juice of the grapes comes in contact with atmospheric air, its ferment combines with the oxygen, and it produces at the same time in the sweet liquid a like phenomenon. A part of the carbon of the sugar unites with the oxygen of the air, and escapes in the state of carbonic acid gas. The other part is converted into alcohol. This

transformation is accomplished very rapidly at a temperature of twenty-five to thirty degrees; but to deprive the ferment of its power to provoke in the alcohol, in ratio as it is formed, the acetous fermentation, one is obliged to diminish the access of the exterior air, by using a vessel more or less closed. The fermentation being completed, if one should continue to keep the wine at this same temperature, the ferment would react upon it, and produce acetous fermentation. To avoid this result, we hasten to fill up the vessels and to place them in a room having a low temperature. In the meanwhile, the ferment remaining in the wine, not being able to satisfy its tendency to unite with oxygen when contained in a partially closed vessel, continues to oxidize itself mildly by means of the small quantity of air which comes to it through the staves. This action continues thus two or three years; and little by little, in ratio as the wine grows old, the ferment which completes its oxidation, falls into the insoluble condition, that is, the condition of lees, at the bottom of the receptacle.

In the fermentations usually made, one is embarrassed, then, by two opposing difficulties. On the one hand, it would be necessary to put the ferment in contact with the greatest volume of air possible, to make it arrive, in the shortest space of time, at a complete oxidation, and to force it in this manner to precipitate itself in the insoluble condition of lees. On the other hand, this measure would have the effect of provoking in the liquor the acetic fermentation, that is to say, its conversion into acetic acid. By the employment of the new process, we are about to see that in a very rational manner we will satisfy these two essential conditions.

When the sweet juices are put to ferment at a temperature of nine to ten degrees centigrade, in shallow vessels, exposing a large surface, where free access of air could be obtained, the complete oxidation of the ferment is accomplished in the shortest time, as well as that of the sweet liquid in which it is merged. In proportion as this action goes on, the ferment falls to the bottom of the vessel in the insoluble state, the state of lees.

Fermentation terminated, it is only necessary to decant the wine separate from its lees, to have it as *perfect*, as *old* as it would have become by the old process after two or three years of age. The act, the phenomenon

which has been accomplished in a wine which has acquired some age, in truth consists precisely in this complete precipitation of the ferment in the insoluble state of lees. The only difference, we repeat it, which exists, is that its precipitation is immediately accomplished in the new process, at the same time with the conversion of the sugar into alcohol; while, in the old process, the deposit is only produced slowly, after a long time, and with the great labors of repeated rackings, etc. This new method of fermentation is applied even to red wines; and what facilitates it in practice, is that usually the temperature is sufficiently low at the time of the vintages. The ciders and the beers made according to these rules, are not liable to sour, nor to turn in warm seasons—very important results, which recommend themselves to the attention of manufacturers.

As every one will be convinced, the new process is simple. It does not offer any difficulty other than that of a choice of the place capable of being maintained at a constant temperature of nine or ten degrees centigrade. Vaulted cellars, on the north side, naturally present all these conditions. We beseech wine growers, manufacturers of cider and beer, to make experiments after the manner we have indicated. They can thus assure themselves if the results by them obtained have been those which are advanced as facts upon the testimony of the celebrated Liebig. In truth, this chemist has first made known this new process as practiced in Bavaria. It is applicable alike to all fermented liquor. The high reputation of learning and responsibility which attaches itself to this name, illustrious in the sciences, assures us that the experiments I advise will not result in disappointment.

By way of recapitulation, we say that, with the juice of the sugar sorgho and the maize, we can, with small expense, obtain the following products: 1. By distillation, a good brandy, or alcohols, of the first quality. 2. Ciders and beers, for commerce and household use. 3. Syrups, capable of profitably replacing the syrups of *fecula*, and for the improvement of the wines in bad seasons. 4. Artificial wines, of the nature of those manufactured by the city of Cette. 5. Vinegars, of a remarkable quality, almost equal to the best wine vinegars. 6. The nourishment of cattle with the stalks used in the press. 7. The manufacture, from these same stalks or other pulp, of a good wrapping paper, which is naturally sized.

RESEARCHES ON THE SUGAR SORGHO.*

BY M. LOUIS VILMORIN.

Translated for the "Working Farmer," by H. S. Olcott.

THIS grass, which seems destined to occupy an important position in the list of our industrial plants, has, as well as the "Igame de la Chine," been introduced by M. de Montigny, and was included in the same package addressed to the Geographical Society.* We still hesitate as to the botanical name by which it should be known. That of *Holcus saccharatus* is manifestly an error; not but that the plant is probably the same as the one previously known under this title, but because the portion of this genus characterized by the presence of a little male spikelet, pedunculated, by the side of each fertile spikelet, has been rejected long since from the *Holcus* family, in the genus *Andropogon* or *Sorghum*. In all probability, the species *Sorghum vulgare* (*Andropogon Sorghum*.) should include in the number of its varieties, the plant in question, as well as the *Andropogon, cafra, bicolor, &c.*, of Kunth. A recent, and still unpublished work by Mr. Wray, which he has had the kindness to send me, notices, as growing on the south-west coast of Caffraria, about fifteen varieties of this plant; and we ourselves recollect, that in a collection of the grains of Abyssinia sent to the Museum in 1840, by M. d'Abadie, and which contained about thirty species or varieties of the sorgho that certain plants attracted our particular attention by the sugary taste of their stalks. Here, as you see, are many causes of confusion, and, at the same time, the elements of a critical work, with which my colleague, M. Groenland, is, at my instigation, occupying himself.

I trust that his researches, aided by the comparative cultivation of different known varieties, will enable us to assign these different varieties to the botanical types whence they are derived. In the meanwhile, the name of *Holcus Saccharatus* may be provisionally adopted, since,

* See the "Revue Horticole," February, 1854, *Holcus Saccharatus*; July, 1854, "Igame de la Chine;" "Bulletin du Comice Agricole de Toulon," 1853, "Liste de l'envoi Montigny"

although evidently inexact as to generic characteristics, it has the advantage of being known, and of never having been applied to other plants.

The plant on which were undertaken the experiments made at Florence in 1766, by Pietro Arduino, for the manufacture of sugar, did, very probably, belong to the same species, but must have been another variety, since he describes the seeds as being of a clear brown, whilst those of this newly imported plant are black, and in appearance entirely identical with the black sorgho of the older collections.

The sugar sorgho is a tall and slender plant, attaining the height of two or three metres, or more, in rich ground (a metre is thirty-nine inches.—O.) The stalks are straight and smooth, the leaves flexible and drooping; in appearance it is much the same as the Indian corn, but much more graceful. It ordinarily forms a top, composed of eight or ten separate stems, each terminated by a tuft of conical shape, and covered with blossoms, green at first, then passing through different shades of violet, to acquire a deep purple hue when completely matured.

It is probably an annual, and its cultivation and time for ripening agree with corn (maize). In the climate of Paris it must be sown as soon as the ground is warm, that is, at the time for the first sowing of beans (haricots); the maturity of the seeds will be more probable, if the plant has been grown in a sheltered nursery, or, better still, in a hot-bed; but, for the extraction of sugar, it will be sufficient to sow it in the open field, provided the soil be light and moderately warm.

The product of the sugar sorgho, consists in the sap contained in abundance in the pith of the stalks, which furnishes three important products: sugar, alcohol, and a fermented beverage similar to cider.*

In truth, this juice, when one has obtained it with care, in a small quantity, by depriving the cane of its green envelope, is nearly colorless, and contains, so to speak, simply water and sugar. Its density varies from 1.050 to 1.075, and the proportion of sugar from ten to sixteen per cent. I include here the total of the two sugars, crystallizable and uncrystallizable, of which the latter sometimes makes a third of their mixture. It is to this quantity of uncrystallizable sugar,

* See the "Moniteur Universel" of 18th November, 1854; "Revue Horticole," 18th November; "Journal d'Agriculture Pratique," 20th November.

that the juice of the sorgho owes the readiness with which it ferments, and the large product in alcohol which it gives, compared to the amount of sugar observed *directly* in the saccharometer.

Considered in relation to the manufacture of sugar, the sorgho seems to me to have small chance of success in the northern and central portions of France—that is to say, in the tracts of country where the culture of the beet is entirely successful. The strong proportion of uncrystallizable sugar which it contains, is not merely so much loss in this manufacture, but it becomes an impediment to the extraction of the other sugar. It is not, however, because the products of the sorgho are poor or difficult to be obtained, but simply that their nature renders them, under similar circumstances, more prolific in alcohol than sugar; and if, in the present state of the market, it is profitable to distil the beet root, which, by the most skillful processes, does not afford an amount of alcohol correspondent to the proportion of sugar which may be extracted, how much more potent reasons are there in favor of the sorgho, whose juice yields more than the equivalent of its extractable sugar.

It will be the same if we consider the sorgho in those warmer regions where the beet cannot grow in competition with it. Some experiments made with the stalks of sorghos cultivated in Algeria, sent to me by M. Peschard of Ambly, Mayor of Phillipeville, produced sugar decidedly superior in quality to that yielded by my plants raised in the *environs* of Paris. The long time occupied in the transmission of the package, caused a partial change to occur, which prevented my determining with accuracy the comparative values of the two kinds of sugar in the sorgho of Algeria; but the nature of the sap, as well as the observations communicated to me by Mr. Wray—formerly a planter in Natal, Caffraria—lead me to think that the proportion of crystallizable sugar will at once become greater where the climate permits the sorgho to attain a complete maturity. This plant, therefore, will fill, in the production of sugar, the void existing between the tropical regions—alone suitable for the cultivation of the sugar cane—and the forty-fourth parallel, which seems to be the southern boundary to the profitable cultivation of the beet root. Beyond this limit, the latter

will probably excel in the production of sugar, while the sorgho, particularly in the provinces of the west and northwest of France, will gain decidedly upon it in the yield of alcohol.

As a sugar producing plant, the sorgho will offer as a recommendation, the ease of its culture and treatment of its sap. Its raw product is probably greater than the sugar cane in countries such as Louisiana, where the latter is known as an annual plant. Like the cane, it furnishes in its leaves and tops an abundance of excellent green fodder. Finally, its molasses, similar to that from the cane, may be used in the manufacture of rum, and the residuum for a similar but inferior liquor. The great difficulties to be met are, the preservation of the stalks, and especially the short season suitable for its manufacture. But beyond these geographical limits which have been heretofore indicated, the warmth of climate will allow of successive plantings. I am told by Mr. Wray, of whom previous mention has been made, that in the vicinity of Natal, the Zulu-Kaffirs keep the stalks sound for a long time by pitting them, as there the ground is warm and moist.

We have just seen that for the manufacture of alcohol the sorgho had the advantage of large proportions of uncrystallizable sugar, which in sugar making is entirely lost. Another advantage is the purity of its sap, which accounts for the fact that the alcohol made from it, as also brandy of first quality, is sufficiently pure for immediate use.

Alcohol, distilled but once, and that imperfectly, which I obtained with very incomplete laboratory apparatus, was absolutely deprived of all foreign flavors, and even my finest liquors, ranging from forty to fifty per cent., have quite an agreeable taste, similar to our *noyau*, and would doubtless be useful to take precedence over the similar products of the beet. When pure, their taste is infinitely less coarse and disagreeable than that of rum; after becoming old they would be very superior.

I have said above, that, besides alcohol and sugar, the sap of the sugar sorgho might furnish a drink similar to cider. In an article inserted in the "Moniteur," November 13, 1854, I essayed to draw attention to the advantages to be obtained from the manufacture of these fermented drinks. This question is still entirely new, and on

can scarcely tell to what it *may* lead ; but after the results I have arrived at in my experiments, made under most unfavorable circumstances, I can but think that it has a profitable future.

The cultivation of the sorgho will probably not be difficult, as it closely resembles that of maize and some millets. The obstacles to be encountered will probably arise in giving it its place in the rotation ; in this respect, there is, I think, more to lose than gain in its introduction, while the beet has constantly increased the aggregate yield of the districts where it has been introduced. The sorgho, as well as maize, is thought to be an exhausting plant ; the experiments I have hitherto made, have been too few to allow my deciding on it from personal observation, but I entirely coincide with the established opinion on the subject, and certainly the species to which this plant belongs, makes it improbable that it could fill the same place in a rotation as the beet.

The value of produce that we may expect from the sorgho is difficult to determine in this state of the question ; my experiments have been made on quite a small scale. The following is the result furnished to me, and the deductions we may draw from it. The small plot of sorgho which I have cultivated open field at Verrières, in a sandy soil of medium quality, was harvested 30th October. We gathered from it as often as we needed it for the different laboratory experiments, besides which one corner was much stunted by the shade of a large tree, and another spot was reserved for a comparison between topped plants and others on which we had left the tufts. The area cut the 30th of October, was 58m40, the yield was (weighed the day after cutting),

Stalks and leaves,	-	-	-	-	285k400
Stalks, without leaves or heads,	-	-	-	-	179k250

The lot was so irregular, and so badly covered, that I wished to make another trial ; so in the part farthest removed from the trees I measured a square plot, where, although the plants were not very tall, they were of average growth and covered the ground well. The dimensions of the square were about 5m32, the yield (weighed the day after cutting) was,

Stalks and leaves,	-	-	-	-	41k110
Stalks, without leaves or heads,	-	-	-	-	26k230

I think that this latter portion may be considered as representing a good average crop, equal to forty-five thousand kilogrammes of beets to the hectare. It is on these figures that I institute my comparisons.

For this plot the plants had been raised in a bed, and the plantation was made during the early part of May.

In another plot, which was sown broadcast on the 18th May, merely a few blades made their appearance. They had greatly needed weeding during the early stages of their growth, and had been, in consequence, much retarded. The yield was on a basis of 38,000 kilogrammes to the hectare.

A third plot, raised in a bed, and planted in the garden, was not weighed; it was gathered from time to time, as wanted in the experiments for determining the periods of the development of the sugar; but I do not fear to deceive myself, in rating its yield, according to the appearance of the plants, at about half that of the 5m32 lot before mentioned.

I have obtained as a result from the stalks, without leaves, an amount of juice equal to fifty or sixty per cent. Of course, if the tops are closely trimmed, or if we experiment simply on the selected stalks, a much larger proportion will be obtained. With proper machinery it should easily touch seventy per cent. In the trial of October 30th, (made with the village cider press,) on 215 kilogrammes of stalks, large and small, from which only the tops and last joints had been trimmed, 106 litres of juice were obtained, showing a density of 1.052. I calculate at least fifteen litres as lost in dampening the surfaces of the stone and press.

I have none of the sugar from the sorgho; have simply made some trials with the saccharometer, decided usually by an evaporation and a comparison with alcohol.

The following is the proportion of sugar in the sap of the plant gathered at Verrières :

13th Oct., 1853,	-	-	-	10.04 for 100 of sap.
28th Nov., 1853,	-	-	-	13.08
Do.	do.,	second trial,	-	14.06

13th Oct., 1854,	- - -	10.14 without <i>inversion</i> .*	} of which was uncrystallizable 11½. } crystallizable sugar 4½.
14th Nov., 1854,	- - -	16	

The amount of alcohol has been determined by a direct fermentation. The following are the figures in the order of trial :

The figures express the absolute yield of alcohol per litre, in the cubic centimetres.

Sorgho at Verrières :

28th Sept., 1854,	- - -	41.
4th Oct., 1854,	- - -	54.

Sorgho of Algiers :

1st fermentation, 17th Oct., 1854,	-	70.	} by the Salleron } apparatus.
2nd trial some hours afterwards	-	74.	
		70.52 on distill.	1 litre 20.
2nd fermentation 18th Oct., 1854,	-	79.52	

Sorgho at Verrières :

20th Oct.,	- - - - -	72.51 on distillation 1 litre
16th Nov.,	- - - - -	63.26 tops removed.
17th Nov.,	- - - - -	60.67 tops not removed.

If we withdraw from this table the yield of the 28th September, which applies to plants evidently too young, and the four others relating to the Algerian sorgho, I find as an average for our climate, 6.3 per cent. in value, or 63 cubic centimetres of alcohol to the litre of sap : an amount which, as one may see, is very encouraging, especially if we consider the excellent quality of the products.

Establishing our calculation for yield on the basis previously given, we have for a hectare planted with sorgho :

Stalks and leaves,	- - - - -	77.270k.
Stalks alone,	- - - - -	49.300
Sap at 55 per cent. of the weight of the stalks,	- - - - -	27.115 lit. or 271 hectols.

* *Inversion*. This word is left in the original, because we cannot translate it literally, and make proper sense. It means, in this case, *without the addition of foreign matter*.

Sugar, calculated at 8 per cent. of sap,	2-169k.
Absolute alcohol, calculated at 6·3 per cent. of the sap,	- - - 1-708 lit.
The best will give, in proportion with these figures :	
Roots, in weight per hectare,	- - - - - 46·000
Sap, at 80 per cent. of weight of roots,	- - - - - 36·000
Sugar, at 6 per cent. of sap,	- - - - - 2-160
Pure alcohol, at 3 per cent. of the beet,	- - - - - 1-350 lit.

The calculation of eight per cent., on which I base the relative proportion of sugar in the sorgho, may be thought too moderate ; but it here refers simply to the extractable and crystallizable sugar, and I do not think I have valued it at too low a figure. If it were proposed to establish a comparison between the sorgho, and the sugar cane of more southern countries, I am convinced that the sum of products in sorgho should be much raised ; but the conditions necessary for such comparison are not in my possession, nor for those which might be made between the same plant and the grape vine, topinambour, the grains, and even the asphodel, in respect to the production of alcohol.

After having examined the advantage that the general cultivation of the sorgho presents, and the considerations which favor the adoption of this plant, it remains to me to cite some of the results yielded by our first experiments, and which may be suggestive for further studies, or as an index for the first attempts in manufacture.

One of the first points that I have sought to determine, without being able to do so in an entirely satisfactory manner, was to know at what epoch in the growth the stalks commenced secreting sugar, and, as a consequence, at what moment to commence to manufacture. It seemed to me that this period coincided with the development of the head ; but the proportion of sugar in the stalk continues on the increase until the grain is in the milk. In a plant in flower, I have remarked, that the richness in sugar diminished between the joints in proportion as we go higher up the stalk, and that, in like manner, the lower portion of each joint was younger and less sugary than the upper part. In this condition, because of the small dimensions and hardness of the smaller joints, it is the central portion of the stalk which is found to be the most rich. I suppose—without having been able to

decide certainly—that at a later stage of growth the lower joints become poorer, or, at least, if the sap does not become poorer in quality, it is manifestly less abundant.

The ripening of the seeds did not seem, at least in our climate, to diminish the yield of sugar ; but as this does not happen with us until the extreme limits of the season, and as our plants have been continually enriching themselves in proportion as their growth continues, the influence of the ripening in these phenomena cannot be determined. It is only in these countries where the plant can attain the maturity of its grains in a continuously warm season, that the matter can be definitely settled. According to the report addressed by M. de Beau regard to the Chamber of Toulon, the ripening did not have with his plants an injurious effect, and he considered the seed and the sugar as two products which may be obtained conjointly ; then, again, according to Mr. Wray, the Zulu-Kaffirs are accustomed to break off, by a slight rapid movement, the tuft of their plants at the time it makes its appearance, and thus increase the saccharine quality of the stalks. This matter, however, is of no importance in France, where the ripening does not ensue sufficiently early to prove at all unfavorable.

The saltish taste of the very lowest knots has led me to think that, in some cases, the salts might accumulate in predominance ; I have had the intention, but not the opportunity, to satisfy myself of this by incinerations. The fact would be in conformity to analogies, and deserves attention. Of no importance as to the manufacture of alcohol, it still would have very much in that of sugar.

The ability to determine as to the richness in sugar of the juice, is quite limited when recourse is not had to a polarizing saccharometer, and, even with this instrument, *inversion* is absolutely necessary for the juice of the sorgho, which always contains a greater or less proportion of poorly made or uncrystallizable sugar. However, if this instrument cannot be made use of, a tolerably good approximation may be arrived at by the following process : After having determined the density of the sap as it passes from the press, it should be caused to ferment with care, and as completely as possible, at a temperature of 25 to 30 degrees, by the use of a very small quantity of the yeast from beer ; the original volume, having been previously marked by a gauge,

should be renewed, after the fermentation, by pure (or better, distilled) water ; then a new volume, measured, of the fermented liquid should be reduced to one half by evaporation, in order to abstract all the alcohol, and again brought to its original bulk by means of water. The areometrical quality of this liquid, taken after the above precautions, will be very nearly a true indication to the amount of correction to give to the density of the juice, provided always that it shows its amount of sugar. We should, at the same time, determine, and separately, the correction due to the small amount of yeast employed.

The process which consists in evaporating the sap to dryness at a temperature of 100° to 110°, in taking it back to the alcohol at 85°, and again evaporating (a simplification of the Péligo process) may, in many cases, give results with sufficient exactness for general practice.

To know the amount of alcohol which the sap can furnish, no other method has succeeded better with me than the direct experiment. In operating upon a litre, and even a half litre, of sap, at a constant temperature of 30°, with the addition of eight to ten grammes of yeast of new beer to the litre of sap, I have frequently had, in eighteen or twenty hours, fermentations sufficiently marked to cause the density of the sap to fall, in this space of time, from 1.060 to 0.997. These figures at once show how easily the sap of the sorgho ferments, and how small amounts of foreign matters it contains, since, during a similar experiment, the juice of the beet root never goes lower than 1.007 or 1.008. This fermentation finished, the alcohol is determined, either by means of Salleron's apparatus, or, what I consider more reliable, by reducing a litre or half a litre of liquid. I have always found the results obtained by this latter process perfectly concordant, and I think we may look upon them as exact. If one has kept a record of the different volumes, as is done in the Salleron apparatus, the residuum after evaporation, are sufficient, as we have shown, to determine the influence which the foreign matters in the sugar exert upon the original density of the sap, and thus we obtain two calculations which prove one another.

The extraction of the sap does not present any difficulties. When it is proposed to determine its proportion, we may employ either of

two methods: 1st. Cut the stalks into small pieces, chop coarsely or abrade, press them; this process gives us figures which approximate to the yield in manufacture. 2nd. Cut into small pieces, wash and dry; this gives the exact figures by comparison.

The extraction of the juices for their treatment, may be accomplished in many ways. In my first trials I made use of a small rolling mill (*laminoir*) of which the work was so imperfect that I was compelled to repress the stalks under a small percussion press of sufficient power. In this way I obtained from fifty-five to sixty per cent. of juice, in proportion as I used canes more or less alike or hard. In another experiment I made use of a cider mill and an ordinary press. The action of the rollers upon the stalks had liberated much chlorophyl, and my sap flowed out much charged with green feculous matter; the yield was the same as above shown; but a considerable loss (about fifteen per cent.) due to the size of the apparatus as compared with the mass of matter on which I operated, carried these figures higher than they should have gone. Without doubt, the use of more powerful methods, such as crushing or hydraulic presses, as at present successfully employed with sugar cane, would give greater results, and such as would quickly meet the considerable expense of commencing them. In those cases where only the distillation is looked to, maceration might perhaps be resorted to with success, as a very economical method, as well as the process which consisted in causing the direct fermentation of the coarsely crushed canes. This latter process would, however, have greater probabilities of success, as will be shown, the crushed stalks constitute an excellent ferment for the juice of the sorgho.

In the laboratory experiments I have always used as a ferment the yeast of beer, because this is the most rapid and the best process for quantitative experiments; it, however, has the inconvenience of imparting a disagreeable odor to the products of distillation. However, the number of substances which are adequate to inducing fermentation is almost illimitable. The Count de Beauregard, who has made, in the neighborhood of Toulon, experiments on an extensive scale, employed with complete success—according to what I have been told by Dr. Turrel—the crushed stalks of the sorgho itself to induce the fermentation of the juice,

All the fruits may be used for the same purpose ; a bunch of grapes crushed between the hands is sufficient to ferment a large vat of several hectolitres, the juice of the sorgho containing naturally a sufficiency of azotized matters to cause fermentation to continue naturally after being thus started ; a ferment of paste, made of the inner part of bread, may take the place of the yeast. In the case where juice largely charged with sugar and derived from very dry stalks, (and of course almost deprived of those younger parts which yield nitrogenous matter) experience a too mild or incomplete fermentation, a little of the flour of French rice will be sufficient to give it all the activity desired.

Once let the movement be established, it is probable that the method of continuous fermentation so happily applied to the distillation of the beet, and which consists in the constant introduction of a fine thread-like stream of sweetened liquid into a vat where fermentation is already active, might be adopted, and thus dispense with all anxiety as to the procuring of different ferments. This method has the additional advantage, that it can perfectly regulate the fermentation, and thus obviate, as much as it is possible, the formation of acetic acid.

It is requisite, in order that the fermentation may be regular, that the temperature should be maintained between 18° to 25° centigrade. This precaution is especially necessary in the small experiments of the laboratory, for which a constant temperature of 25° has always succeeded with me. I have made mention of a process of purification based upon the use of oak-wood shavings, and which entirely destroys the taste of the green matter arising from the crushing of the bark of the stalks by the rollers.* I have observed since then, that, if they are used in excess, either by too prolonged an ebullition or by increasing the proportion of shavings, (which should *never* exceed 200 grammes to the hectolitre of juice,) this method actually opposes the fermentation. We should therefore give some attention to the proper method of employing it, the more, because for distillation the juices obtained from the rolling mill are so clear as not to have a disagreeable flavor, even when they are put to ferment in their raw state. Perhaps other processes, such as the use of white wood and the coal of juices, might be successfully employed for the defecation or clarification of juices.

* See *Journal d'Agriculture Pratique*, (No. of 25th November, p. 420.)

Lime, which perfectly clarifies the juice, cannot be applied to distillation, because of the disagreeable odors which it develops.

Relative to the cultivation, there will remain certain points to be decided upon. According to the observation communicated to me by M. Ponsart, the grain requires, for perfect germination, to be very slightly covered, which requires some care in the field sowings; for, in this case, a large number of seeds will be lost, because of the fact that the harrow covers them with too thick a layer of earth. This explains, perhaps, that in the countries where they cultivate the common sorgho, it is customary to use one decalitre to one and a half decalitres for the drill crops, and from five to six decalitres for broadcast sowing; whilst the enumeration of the seeds contained in a kilogramme would show, by calculation, a quantity of grains five or six times less.

The plants should necessarily be cultivated in drills, in order to give them thorough cultivation and proper care; these are indispensable, especially during the infancy of the plant, which is sometimes quite protracted. The plan proposed by M. Ledocte—to associate with the plant we cultivate, when it germinates or develops slowly, another of rapid growth, such as colza, lettuce &c., so that in a very short time the eye of the farmer may distinguish the lines or plots occupied by the plants which his cultivator should spare—seems worthy of being recommended in this case; because the fine sprouts of the sorgho, being confounded with grass, renders the operation of the first cultivation very difficult. The layering of the branches proposed by M. Henzé, seems to me but slightly practicable. It is only in September that they have become strong enough to be layered, and the plants thus procured would not attain, even in a year's time, a development which would warrant their cultivation. I shall have an analogous observation to make on the separation of the plant raised in a bed; by decreasing the branching, this process would oblige one to plant closer, which would compensate for all the advantages to be derived from it.

The experiments relative to the preservation of the stalks, merit above all to be followed with attention. I have heretofore noticed the use of covered pits in Caffraria; a commencement of drying by the sun, having the effect of concentrating the sap in the stalks, might

make their preservation more certain and easy ; finally, the preparation of small clippings artificially dried, might perhaps pay for the extra expenses which their preparation would cause, by enabling us to manufacture throughout the entire year. All the questions which attach themselves to this order of facts, are so much more important to study, because if they obtain a good solution, they would result in remedying what may at present be regarded as the weakest point of the sorgho, the preservation of the stalks during a sufficiently long time to accomplish a regular manufacture.*

THE SORGHO IN AMERICA.

Wishing to know something of the results of experiments instituted upon this plant in our own country, I have written to Messrs. Parker, White, & Gannet, seedsmen, of Boston, who are correspondents of Monsieur Vilmorin, and have the seeds of the sorgho for sale, and they answer as follows :

Boston, November 22, 1855.

MR. H. S. OLCOCK,

Dear Sir,—We have ourselves cultivated the *Holcus saccharatus* the past season, for the purpose of supplying ourselves with seed. It grows readily, and ripens the seed with as much certainty as Indian corn.

There is very little probability that it will be grown in New England for the purpose of making sugar, but we esteem it highly as an article for feeding cattle, cutting it up for a green crop as soon as it is four or five feet high, when it has more foliage than corn, and is full of sweeter juices.

We believe it can be profitably grown for the production of sugar in some of the northern slave states, and may possibly, when it shall have been once fairly introduced, take the place of the common cane

* This tendency to decay is the chief objection urged by those who oppose the cultivation of green corn for fodder, and it seems reasonable to suppose that those precautions which ensure the preservation of the corn stalks, would be equally applicable to the sorgho.—TRANS.

in some of the present sugar growing sections. Enclosed is an item which we have picked up.

"M. Avequin, the distinguished chemist, says the *N. O. Bee*, has exhibited to us a specimen of very fine, well grained sugar, obtained from the plant known to botanists as the *Holcus saccharatus*, and commonly styled 'Sorgho.' It is a species of corn, producing a small grain like millet, and is very easily cultivated. The sugar is extracted from the stem or stalk, and the yield is quite large. One acre of ground in cultivation, will produce from eight hundred to one thousand pounds of sugar. The sorgho has the advantage of ripening in summer, so that the grinding can be effected from the close of July to the middle of September. The stalks and entire plant afford excellent forage for cattle."

Respectfully yours,

PARKER, WHITE, & GANNET.

I then wrote to M. Avequin, and through his politeness received his letter addressed to *L' Abeille de la N. Orleans (N. O. Bee)*, a translation of which is annexed :

To the Editors of the Bee :

You have published at different times during the past year, some facts concerning the sorgho sucré, *Holcus saccharatus*, called the Chinese Sorgho. These communications failing to give anything exact as to the value of this plant, as an object of culture in Louisiana, or as to the amount of sugar to be extracted from it, allow me to add something to what is already known of it, and thus assist in arriving at definite conclusions

For some two years past the seed has been sown by several planters in small quantities, and with favorable results ; but I know of none who have attempted to extract the sugar in large quantity. Still, this plant is quite important ; it ripens three months before the sugar cane, and it can be crushed from the early part of August, and throughout the whole of September, or still later even. This is at once a decided advantage. But those who have written upon the sorgho have, to my

mind, a little exaggerated its sugar producing qualities, and its yield per acre.

* * * * * The sorgho that I examined towards the middle of September, had arrived at full maturity, perhaps a little past; it had been sown in good season.

The expressed juice of the sorgho is somewhat more turbid than cane juice, but it is clarified by milk of lime as readily as is the latter. The green froths which arise from it are nearly analogous to those from the juice of the cane. This sap had a density of 1064; it reached almost 90° Beaumé, and had an acid reaction similar to that of all the juices of canes. This property it owes to the acid phosphate of lime which it contains. This same salt exists to an equal degree in the sugar cane.

The sap of the sorgho contains a trifle more of salts of potash, acid phosphates of lime, and phosphate of magnesia, than any equal quantity of cane juice—at least I have found it so in the sap of the sorgho which I analyzed; it may possibly be that other specimens would contain less.

A litre of the sap of the sugar sorgho contains 7.50 grammes of salts of potash, acetate of potash, muriate of potash, and sulphate of potash. A gallon of it contains 28.38 grammes, or little more than an ounce.

A litre of the sap gives 2.18 grammes of acid phosphate of lime and of phosphate of magnesia. A gallon contains 8.23 grammes. A litre has given 0.12 grammes of hydrated silica, mixed with oxide of iron and manganese. A gallon contains 0.45 grammes. These matters are all in solution in the sap of the sorgho, together with other organic matter, such as albumen, vegetable fibrine, chlorophyl, &c. These latter substances offer no impediment to the extraction of the sugar from the sorgho.

The sorgho, from a given weight, affords less sap than the sugar cane, at least such is indicated by my experiments. It may be that if taken when less ripe, the sorgho would give a larger yield of sap. From several stalks of sorgho of good quality and fully ripe, I have only obtained 42 per cent. of juice by expression, whilst I have readily obtained 64 per cent. from the cane by the same process.

When a litre of sap of the sugar sorgho weighs 1064 grammes, about 9° Beaumé, a gallon of this same sap weighs 4 kilogrammes 0.31 grammes, or 8 lbs. 14 oz. 2 drachms 14 grains, English weight. This gallon of sap contains 652 grammes of sugar, salts, and organic matters, or 1 lb. 7 oz. 4 gr., English weight.

It gives per 1000 parts, in weight :

Sugar	-	-	-	-	-	-	-	-	152
Salts and organic matters	-	-	-	-	-	-	-	-	10
Water	-	-	-	-	-	-	-	-	838
									1000

To make one thousand lbs. of unrefined sugar, cleansed and well dropped, with sap of the sorgho of a density of 1064, requires 1250 to 1300 gallons of sap. This sugar is of the same kind as that extracted from the cane.

The sugar of the sorgho will give almost as much molasses as the cane sugar in Louisiana, perhaps a little less, because it has a density a trifle more than the average of the cane in Louisiana, at least that which I have examined.

One thousand pounds of this sugar thoroughly clarified, will not give less than fifty-five gallons of molasses ; in some instances the molasses would be in much greater proportion. In this respect the sorgho will share the vicissitudes of the sugar cane—succeeding years would not give equal results.

An arpent (six sevenths of an acre) of sorgho, well cultivated, with a good yield, might give eight hundred to one thousand lbs. of raw sugar, clarified and saleable. The experiments which I have made upon the subject show this clearly enough. Certainly the sorgho *cannot* supersede the sugar cane in Louisiana ; but it has great advantage over the cane, in that it can be crushed from the early part of August, and throughout September, whilst the cane cannot be crushed until about the first of November. It remains to be known if this advantage can reconcile itself with the other interests of the planter ; this I have not sought to establish.

The sap of the sorgho, after having been clarified, as do all the

sugary juices, can take on the alcoholic fermentation; it is almost needless to mention this here. It may be distilled, and will yield *tafia*, the same as that from the sugar cane. The molasses dripping from the raw sugar of the sorgho juice may likewise produce rum or alcohol, as desired; but these alcoholic liquors have nothing of the flavor of Cognac brandies, and cannot replace them in their various uses.

We will conclude this notice by saying that the sugar sorgho makes an excellent forage for animals, preferable to corn stalks. Cows, horses, mules and oxen devour the leaves and the entire stalk, even to the last particle. We ask of the planters to make trial of this plant, either as a green fodder, or for the extraction of sugar. An experiment upon twenty-five or thirty acres would be no great expense for them.

Agree, gentlemen, &c.,

AVEQUIN.

REPORT

Addressed to his Excellency MARSHAL VAILLANT, Minister of War in France, upon the Culture of the Sugar Sorgho, by DOCTOR TUREL, Secretary of the Assembly of Toulon, &c., &c. Translated by HENRY S. OLCOTT, Westchester Farm School, Mount Vernon, N. Y.

(From "SUGAR CANE AND SUGAR MAKING," by CHAS. F. STENSBURY.—A. O. MOORE, N. Y.)

MAY IT PLEASE YOUR EXCELLENCY,—The sugar sorgho (*Holcus saccharatus*) is a botanical species not entirely unknown to more southern countries. It was cultivated in the 15th century in Italy, where it had probably been introduced by the Venetians and Genoese at the period of the development of their maritime commerce. At the commencement of that century, and as a consequence of the Continental war, we notice in Italy large experiments with the sugar cane; but, whether on account of their process for the extraction of the sugar not being sufficiently perfect to warrant the idea that it could exclude other colonial products of an analogous nature, or

because their variety was not as rich in sugar as the new stock, its culture was abandoned.

The Botanic Garden at Toulon has for a long time possessed a specimen of this plant in its collections. M. Robert, who was the director, cultivated it at one time, but neglected, and finally lost it entirely.

These historic facts go, your Excellency, to substantiate the strong claims which M. de Montigny has upon the gratitude of the entire country.

It is through the means of the Geographical Society that I had the pleasure of receiving, in 1851, a small specimen of ten grammes of seeds of the sorgho. M. Jomard, President of the Society, sent me a package of thirty-two kinds of grains or roots, and I should, as Secretary of the Assembly, acknowledge the zealous coöperation of my colleagues in the experiments made with them.

It is to M. Robert that is due the honor of propagation of the sugar sorgho ; a single seed ripened with him in 1851. 'Tis the plant springing from this single seed which has produced all the seeds distributed by him in the department. It is by means of the seeds thus obtained by M. Robert, that M. Rantonnet has been able to make his extensive experiments.

The Sugar Cane of the North of China, which is the name by which we are acquainted with this plant, was recognized, immediately on its development, as botanically identical with the *Holcus saccharatus*, or sugar sorgho. As soon as the crop could be gathered, one of my colleagues, Doctor Ardoin, experimented with the juice which he obtained by expression, and he presented to the Assembly, in the month of August, a specimen of molasses of a brownish yellow color, the flavor of which was beyond doubt strongly saccharine.

The committee on which I had the honor to serve with Messrs. Hugolin, Letscher, Ardoin, de Beauregard, and C. Burle, divided amongst themselves the various experiments, and the results arrived at confirmed the hopes awakened by the first experiments by Dr. Ardoin.

We obtained from 50 to 60 per cent. of sweet juice from stalks stripped of their leaves and put through the press, and in this juice we found a per centage of saccharine matter varying from 10 to 20 per cent. The liquid was not examined in the polarizing apparatus ;

but the opinion of one of us was that the sugar in the sorgho was identical with grape sugar, and of course uncrystallizable.

However, this opinion was not accepted in the absence of proof, although advanced by an able chemist; and M. Beauregard, our president, aided by M. Verignon, a chemist at Hyères, undertook new experiments, which resulted in the procuring of magnificent cubic crystals of sugar, similar to the crystals of cane sugar, formed in the center of a liquid when it is dissolved. But this laboratory experiment possesses only a secondary interest, compared to the trials made by M. Beauregard, and whose result seriously affects the industry of our country.

So strong an analogy as that which had been supposed to exist between the sugar of the holcus and the grape, would strongly suggest this question—Whether the sorgho sugar ought not to be transformed into alcohol as readily as is that of the grape. We owe it to the honor of our Assembly, and to M. Beauregard, the president, to record the fact, that the question of the production of alcohol from the sorgho was first entertained and practically demonstrated by that gentleman.

The grape disease, by exhausting for a long time, perhaps, the most abundant source of alcoholic productions, has forced our industry to seek for other means for the extraction of alcoholic products. Hence, the beet is no longer used for sugar, but for alcohol; hence we have distilled the cereals, in which alcohol had been produced, by the assistance of a chemical agent. In view of the high price of the cereals, and of the impending scarcity that bad harvests threaten, the government is justly alarmed and has prohibited the distillation of grain. This provision, thanks to our Assembly, will shortly be entirely useless, for the sugar sorgho is endowed with greater profusion of alcohol than all the other substitutes for the vine. M. de B., in a report made to the agricultural assembly of Toulon, at the session of November 6th, 1854, has shown that, having distilled the juice of the sorgho, fermented by the assistance of the grape cluster stalks, or even of the bagasse of the cane itself,* he has obtained, by means of

* May not the bagasse be treated with sulphuric acid, as is done with wood and rags, to transform them into glucose; thus obtaining alcohol, by the fermentation of the sugar produced in this manner?

very imperfect apparatus, five per cent. of pure alcohol. This alcohol is of very fine flavor; and he considers it comparable to our excellent tafia; furthermore, he has produced a wine quite similar in flavor to the cider of Normandy. S. Vilmorin obtains with the common cider mill, 50 per cent. of juice, an average density of 1050 to 1070, which he concentrates by evaporation. He adds about two hundred grammes of oak shaving to a hectolitre of juice; ebullition reduces the liquid to a half, which he finds completely purified by the precipitation of the albuminous matters which combine with the tannin of the shavings. The purification may be obtained with cherry shavings; and to the wine obtained by fermentation can be given, by using a little yeast, different flavors, by infusing in the liquid during fermentation flowers of elder, hops, fir buds, or berries of the juniper.

In continuing the evaporation of part of the juice, a caramel syrup is obtained, which is added to the juice after the first frothing or fermentation. A slightly saccharine liquid is thus obtained, which is made sparkling by putting it in bottles, before the fermentation is entirely completed.

When the sap is intended for distillation, it is necessary, adds M. Vilmorin, that nearly the whole of it should be fermented with the presence of oak shavings. 1-20 only of the juice will be ample to expedite and regulate the fermentation, which one can determine, for the first time as needed, by the addition of a small quantity of yeast. M. de B. has made the juice of the sorgho ferment without previous working in his wine vats, by means of grape stems of his vintage. He has obtained, from the distilled juices, an alcohol of first quality, in which it is impossible to distinguish the slightest herbaceous flavor; for he has sold his products, in the Marseilles exchange, at the current price of the ordinary alcohols.

By adopting for all France, the result obtained at Verrières by S. Vilmorin with the sorghos cultivated in his estate, we would have the following result: the sorgho yields a maximum of 50 per cent. of the weight of its stalks in saccharine juice; the minimum production calculated from the yield at Verrières, would be thirty thousand kilogrammes of juice to the hectare; we could extract from it twenty-one hectolitres of alcohol, worth three thousand seven hundred and eighty

franca, which would be a yield, per hectare, that no other agricultural product can equal.

The culture of the sugar sorgho needs, as for all annual plants of considerable growth, a soil rich and considerably improved. In Provence and Algeria, the sorgho could not ripen its seed and pass through all the stages of its growth without the assistance of irrigation. However, in the rainy seasons, we can hope for its complete maturity; for in 1853 several of our colleagues of the Assembly have obtained magnificent sorghos, and harvested good grains on a soil quite dry, and where irrigation was not practicable. Wheat soils, and alluvial ones, would suit it especially. We have seen it attain rich growth on a stony and light soil.

We have already mentioned that the sorgho attains a height of three or four yards. Each plant produces four to six stalks, of which each one is surmounted by a panicle weighing two hundred to three hundred grammes, and of which each one may yield two hundred to three hundred grains. The panicle of the main stalk is the first to arrive at maturity; the secondary panicles ripen at about the same time, and even the subsequent ones ripen their seed when the autumn is not too severe.

About the end of September, the panicles begin to ripen; and it is at the transition from the milk state, that the saccharine richness of the plant is carried to its highest degree.

This fact, so interesting as regards the reproduction of the plant and the yield of grain, has been proved by our honorable President, M. de Beauregard.

M. Vilmorin has moreover observed, that the saccharine matter in the stalk decreases gradually, from the base to the top; and it is in the spaces between the lower joints that it is the most marked.

The plant is essentially rich in hydro-carbon products (sugar, alcohol); it is therefore improbable that nitrogenized manures will be as indispensable to its growth, as to plants abounding in gluten (wheat, barley, oats); in this view of the case, the crop would not be an exhausting one.

It is not without design that we introduce into the consideration of an industrial plant, its value as a fodder crop. The rearing of cattle,

indispensable on the well cultivated farm, cannot be profitably undertaken, without the aid of fodder crop ; and if the plant which occupies our attention demands simply the manures which cattle furnish, it gives, on its part, for their nourishment, a remarkably large crop of fodder.

In truth, stock greedily eat the leaves of the sorgho, which can be fed to them green, at the time when the meadows have ceased to yield cuttings ; and as they can be gathered from September to December, it follows that, during four months, the sorgho will furnish an agreeable and nutritious fodder. Horses and mules are exceedingly fond of it : it can be cured for winter.

We have only adverted to the possibility of the economical extraction of the sugar from the sorgho ; but the discoveries which we owe to the talent of M. de Montigny, of the production of sugar from this plant by the inhabitants of the north of China, authorise the belief that, when their processes of extraction become familiar to us, the sugar sorgho, by reason of its saccharine richness, can profitably replace, in Provence and Algeria, the beet, whose culture for sugar is not expedient in warm climates.

In truth, the sugar beet, which contains only eight to ten per cent. of sugar, cannot be compared, in saccharine richness, with the sugar sorgho, which has from sixteen to twenty per cent. And, furthermore, if we consider that beet juice yields but three to four per cent. of alcohol—and that unsuitable for wine making—whilst the juices of the sorgho yield from six to ten per cent. of excellent alcohol, appropriate for all industrial and economical purposes ; we shall have the most just and least exaggerated idea of the future of the plant upon which I have sought to lay before you the facts practically demonstrated. It but just appears above the agricultural horizon ; and while it already recommends itself by precious qualities, it causes us to cherish most flattering hopes. Thus, your Excellency, have I endeavored to enumerate its strong claims to your enlightened attention, for its bearing upon the interests of Algeria.

I am, with respects, Sir, &c. &c.

S. TURREL,

Secy. of the Agricultural Assembly of Toulon.

Table of French weights and measures, referred to in the preceding and succeeding reports.

Kilogramme,	-	-	-	-	2 lbs. 5½ drachms.
Hectare,	-	-	-	-	2¼ acres.
Gramme,	-	-	-	-	½ dr. avoirdupois.
Litre,	-	-	-	-	2 1-9 wine pints.
Centimetre,	-	-	-	-	39-100 of an inch.
Decalitre,	-	-	-	-	about 2 gallons.
Metre,	-	-	-	-	39 inches.

REPORT

Addressed to his Excellency the Minister of War, upon the Culture of the Sugar Sorgho, by M. HARDY, Director General of the Government Nursery at Hamma, in Algeria, Member of the Imperial Society of Acclimation. Translated for this work by H. S. OLCOTT, of the Westchester Farm School, Mount Vernon, N. Y.

(From "SUGAR CANE AND SUGAR MAKING," by C. F. Stansbury—A. O. Moore.)

On the 18th of May last, I sowed plots of sorgho sucré, comprising a total area of about sixty-five square rods, (Eng.,) of a nearly uniform quality of soil. The ground had been deeply worked and fully manured. The seed was sown in drills eighty centimetres apart. When the young plants had become sufficiently strong, I thinned out, leaving them at thirty to thirty-five centimetres apart in the drill. The plantation received during the season three hoeings and three slight irrigations, which consisted in turning a small stream of water through an open trench running alongside each row. Not more than four hundred cubic metres of water were necessary to the hectare. At the last hoeing the dirt was drawn to the foot of the plants, in such manner as to form a slight hill, both for the purpose of protecting the plants against the wind and to favor the development of extra roots which spring from the stalk, as is the case with Indian corn.

The majority of stalks attained a height of four or five yards; a great number did not exceed a thickness of ten to eleven centimetres. The seed ripens about the middle of September; and despite the attacks of sparrows, the sixty-five square rods gave me four hundred and twenty-five kilogrammes of seed, which would equal two thousand five hundred kilogrammes per hectare.

I have also cut the stalk, to make comparative weighings from various marked portions of the three plots. It was noticed that the plants had usually from three to seven stalks, (suckers,) or an average of five. The stalks stripped clean of their leaves, then deprived of the upper ends, which contain little or no saccharine matters, were reduced to an average length of 2.5 metres (a little over eight feet). From these pieces I obtained by weight a yield of 83,250 kilogrammes of saccharine stalks to the hectare.

The preceding year, in my first experiment with the sugar sorgho, I had planted it in groups about two and a half feet apart each way. The stalks grew nearly like the crop of the present year; but, crowded too much by this close planting, they did not attain the weight and diameter of this year's stalks. Their yield per hectare was scarcely forty to forty-five thousand kilogrammes.* The spacing and mode of planting, in 1855, seemed entirely suitable for soils of good fertility, the only ones on which the sorgho culture should be attempted, if it is desired to obtain its full development and greatest possible yield. This wide culture likewise enables us to make use of horse tools, such as the horse-shoe for cultivation, and the light plow to make trenches for irrigation.

The stalks bruised in a mortar after having been cut into small pieces, and then submitted to strong pressure, yielded sixty-seven per cent of sap.

The juices had at the end of September, at the time of gathering the seed, a density of $8\frac{1}{2}^{\circ}$ Beaumé, which would indicate an approximative saccharine richness of thirteen per cent. I distinctly say an *approximative* richness, not *actual*, for I have no saccharometer at this

* NOTE BY TRANS.—The crop of sorgho raised during the last season—1856—at the Farm School, was planted in this manner—2½x3 feet—six stalks to the hill. The plants attained an immense height, but were so weak as to be prostrated by a wind storm, and the seed did not ripen in consequence.—H. S. O.

place ; and this is the only instrument which enables us to determine the per centage of uncrystallizable or grape sugar. It is, therefore, to the polarizing saccharometer that we must look to determine this important point. But supposing the entire sugar to be crystallizable, the hectare would give the following result : $\frac{32.250}{100} \times 67 = \frac{55.717}{100} \times 13 = 7254$ kilogramme of sugar, or the equivalent for one portion of uncrystallizable sugar.

The sap containing grape sugar, or uncrystallizable, is not less susceptible of alcoholization than if it had none but crystallizable. But I will again refer to this matter.

The stalks which had been robbed of their seed heads having been left standing in the field, I had the satisfaction to see them two months after the gathering of the seed still standing, untouched by the wind, and safe from the attacks of worms, and, moreover, retaining their original sweet taste. Thus we see that not only does the sweet principle develop itself at the time of ripening the seed, but it continues to exist, unchanged, in the stalks long after the seed tops are removed ; and it is absolutely proved that in Algeria we may use the seeds of the sorgho when they are fully ripe, without lessening the crop of the saccharine matters contained in the stalk.

The sorgho seed has at present an inordinate value, because of its rarity ; but this will be but of short duration, and the price will rapidly descend to a level with the ordinary cereals, the yield being so very prolific as to quickly surpass even the most unusual demands for planting.

Besides the foregoing uses, this seed will bear a certain industrial value, and have other employment than the rearing of poultry or pigs, like the seed of the broom corn. Doctor Sicard, of Marseilles, has discovered, during the past year, that the seed of the sorgho sacré contains in the outer coating a very beautiful red color, from which he has obtained all the various tints ranging from red to violet. M. Chevreul has likewise noticed the remarkable and entire characteristic facility of this dye for tinting silk.*

* I have repeated the experiment of Dr. Sicard and M. Chevreul with entire success. The hulls, stripped from the seed, and boiled for about fifteen minutes in pure water, yield a deep purplish red solution, in which I have dyed cotton and silk fabrics. The tints range from deep purple to a splendid opal. The dye, I find on microscopic exam-

For my part, I have extracted from the stalks a product which will not be without its uses, and of which I will speak again.

The sorgho sucré is, so to speak, perennial, for I have plants which are now at the end of their second year of growth and are *commencing to grow for the third season*, and giving every evidence of an intention to again complete the maturity of their growth. But I do not suppose it would be useful to preserve a plantation throughout several seasons. I believe that the attempt would prove more troublesome than profitable. The second year the stalks scarcely attain a height of one and a half or two yards.

These first experiments which I lay before your Excellency are not the only ones undertaken by me; I have made diligent study of its virtues, and obtain the following results:

The stalks which had been topped to gather the seed, were allowed to stand as they grew until the month of February last. I made extractions of juice at various periods.

First attempt (made in the latter part of September at the gathering of the seed). Obtained sixty-seven of juice for one hundred of stalks; this juice showed a density of eight and three quarters.

November 28, I obtained fifty-two per cent. of juice; density nine and a half.

January 31, obtained fifty-one per cent. of juice of a density of eight and a half.

Finally, February 16, last trial, I obtained 49.5 per cent. of juice, with a density of eight degrees.

Thus, from the end of September until the end of November, the stalks standing in the field lost nothing of their proportion of saccharine principle; for if the quantity of juice had diminished some fifteen per cent., representing 0.66 per cent. of alcohol, on the other hand, this juice had gained some 0.75 per cent. in richness, representing

ination, is contained in the fibers which make up the inner part of the seed hull, and in the compact siliceous structure of the hull itself. The fibers look like hemp fibers dyed. The hull, after being subjected to prolonged boiling, is not unlike in appearance a piece of sheet India rubber. The color of the seed covering is not black, as is generally supposed, but a very deep purple. From the readiness with which the dye separates from the hull, it seems as if this feature of sorgho culture would prove far from unimportant.

nearly the equivalent of alcohol; whence it follows, that the saccharine or alcoholic *richness* had on the contrary increased.

From the close of November to the middle of February, the diminution in weight and quality has not arrived at such a degree as to prevent the economical manufacture of products throughout this long lapse of time. This is of great moment. In fact, whilst in the middle of France the frosts have destroyed the stalks of the sorgho as early as the end of October, in Algeria these stalks may be preserved without alteration, so to speak, and without expense, throughout almost the entire winter, for the use of the distilleries.

The trials for alcohol producing, were made on the juice extracted January 31. I put in two globes of glass, two litres of juice, with the addition of a little brewer's yeast, somewhat old and slightly sour; and two other litres, without yeast. Then I boiled some cuttings of the sorgho, which I then peeled and pressed. This juice was put in a third globe. The three glasses were put in the green house for young plants (*serre aux boutures*)—the temperature ranging from twenty-two to thirty degrees centigrade.

The next day, the juice which had been mixed with no foreign ingredient, and which I call the plain juice, commenced fermenting. Numerous bubbles of carbonic acid gas arose; but neither in the boiled juice, nor in that mixed with yeast, were any signs of fermentation manifested.

The 3d February, I made a trial with the Salleron apparatus. The plain juice, gave two and a half per cent. of alcohol; juice with yeast, gave 0; boiled juice gave 0.

February 6th, second trial made. Plain juice, gave 6.20 per cent. of alcohol; juice, with yeast, gave 0; boiled juice, gave 0.

February 8th, third trial. Plain juice, gave 10.30 per cent. of alcohol; juice, with yeast, gave 0; boiled juice gave 1 per cent.

February 10th, fourth trial. Plain juice, gave 9.90 per cent. of alcohol; juice with yeast, gave 0; boiled juice, gave 3.20 per cent.

February 12th, fifth trial. Plain juice gave 9.30 per cent of alcohol; with yeast gave 1; boiled, gave 5.40.

February 14th, sixth trial. Plain juice gave 8.60 per cent. of alcohol; with yeast, gave 0; boiled, gave 2.40.

February 16th, seventh and last trial. Plain juice, gave 7.90 per cent. of alcohol; with yeast, gave 0; boiled juice gave 1.90.

This series of experiments seems conclusive, and proves that the juice of the sorgho carries in itself a fermentative principle; and that it is not necessary to add to it any yeast to obtain the alcoholic fermentation, if it be simply submitted to the proper temperature. The addition of yeast, which, besides being of bad quality, neutralized the action of the natural ferment of the albuminous matter in the juice, and hastened rapidly the acidulous fermentation. The boiled juice did not experience a thorough fermentation, because the albuminous fermentable principle was coagulated by the cooking.

At the end of eight days, the fermentation of the plain juice of the sorgho arrived at its maximum of alcoholization, and at this point it should be submitted to distillation; two days after, its alcoholic richness diminished, and it passed to acidification.

The seed of the sorgho is equally as susceptible of giving a notable per centage of alcohol, as the other cereals; I myself have, as yet, made no experiment in this direction; but, by analogy, one is naturally led to conclude that it should be so. The seed of the common sorghum, (broom corn,) according to M. Bassel, gives 24.75 per cent. of its weight in alcohol; that of the sugar sorgho should not yield less; whence it follows, that the two thousand five hundred kilogrammes that one hectare produces, should give six hundred and eighteen kilogrammes, and seventy-five grammes of alcohol. This would, perhaps, be the best use to put it to, whenever the supply shall exceed the demand for planting.

When the sorgho stalk has arrived at perfect maturity, a waxy efflorescence develops itself on the surface, similar to that of several varieties of sugar cane, and which is simply *cerosie*. *Cerosie*, or vegetable wax, is dry and hard, and may be pulverized; it is fusible at ninety degrees; mixed with a little purified tallow, it may be made into candles, which give a beautiful bright light.

I scraped the *cerosie* from a number of stalks, and found that a hectare should give one hundred and eight kilogrammes, four hundred grammes of this substance—costing an average price of two hundred and fifty-two francs for hand labor in gathering it. Beeswax being

sold at four francs per kilogramme—cerosie should be worth three francs fifty cents; this would give a receipt of three hundred and thirty francs sixty-two cents, and a net profit of eighty-eight francs sixty-two cents, to be added to the other net profits of the sorgho culture. This item would moreover assume a new importance, if we find (as I doubt not we shall) processes of extraction of the wax, more economical than the one employed by me, which consists in scraping the stalk with a knife, in a similar manner to the process employed with the wax-bearing palm tree.

The forage for stock which may be obtained on a hectare, both by stripping the leaves and by the after-math, has a determined value, and it is no exaggeration to estimate it at two hundred metrical quintals* when the stalks have been dried, and this, at four francs per quintal, would yield eight hundred francs.

The total profit and expense of a well cultivated hectare of sorgho sucré (molasses and syrup not being considered) would be as follows :

7954 litres, 68 of alcohol, at 140 fr. per hectolitre, the actual price in the principal markets of France, deducting 10 fr. per hectolitre for transportation, waste, and expenses of all kind, would be 130 fr. per hectolitre,	- - - - -	10,341
108 kil. 400 grammes cerosie, at 3 fr. 50 c. per kil.	- - - - -	330 62
20,800 kilogrammes forage, at 4 fr. per quintal,	- - - - -	800
		<hr/>
		11,471 62

EXPENSES.

Labor, 80 fr. ; cultivation, 40 fr.,	- - - - -	120 fr.
Sowing,	- - - - -	30
Hoeing, weeding, thinning out,	- - - - -	90
Irrigations,	- - - - -	40
Manure used,	- - - - -	60
Harvesting,	- - - - -	80
Rent of ground,	- - - - -	100
Cost of extracting wax,	- - - - -	252
		<hr/>
		772

* Quintal, 112 lbs.

Cost of distilling, at 30 fr. per hectolitre, including hand labor, fuel, casks, general expenses, interest on capital employed, keeping of material, &c., - - -	2386.40
Total expenses to be deducted, - - - - -	3158.40
Net profit, - - - - -	Fr. 8313.22
	Or, \$1662.65

This enormous profit would be due to the actual high price of alcohols; but, supposing even that this should fall to 70 francs per hectolitre, which is certainly the lowest point it could reach, the total net profit per hectare would still be 3,350.40 francs. It is hence readily seen that the production of alcohol from the sugar sorgho in Algeria will be a leading industry of such nature as to resist all crises, and which cannot be too sedulously fostered.

The sugar sorgho needs, to pass through all the phases of its vegetation from the planting of the seed to the maturity of its grain, 2,760 degrees of heat. The middle of the month of May is the most favorable time for planting and to secure fine growth. If sown at that time, the plant would ripen about the 15th September, and consume 122 days from planting to ripening of seed. This period is, undoubtedly, the most favorable to obtaining seed for planting. However, the growth may be made at a lower temperature, say an average of 12° to 15° (cent.); this would enable us to commence planting about the 1st April. The seed planted at this time would produce plants ripening their seed towards the 13th August, at the end of 135 days of growth. Thus successive plantings might be made until the middle of July; the latter would ripen seed in the latter part of November, after 143 days of growth.

The last mentioned date is, I think, the very latest on which planting may be done, with any certainty of ripening the stalks. Judging from the marked peculiarity possessed by the stalks of the sorgho, of remaining unchanged for several months, it is certain that distilleries can be kept working on them for six months of the year.

They have seemed to fear, in the south of France, that in the long

run the sugar sorgho, if propagated exclusively from its seed, would surely degenerate, and it has been recommended to propagate by suckers. Their fears might be realized if this species were cultivated without any foresight, in the immediate vicinity of some of its congeners, broom corn for instance. Degeneration might in some cases result, but there is nothing to be apprehended if the sorgho be kept entirely separate and distinct. The propagation by suckers and shoots would scarcely be practicable on a large scale; besides, such proceeding would result in producing a feeble offspring; the new plant would be less vigorous and profitable. Nevertheless, to test this point, I have made a small plantation of suckers of the sorgho sucré, and intend to make precise experiments during the coming season.

I am, your Excellency, &c.,

HARDY,

*Director of the Imperial Central Nursery,
Hamma, Algeria, 1856.*

That our readers may make the necessary allowances in comparing the results set forth by M. Hardy with those in our climate, it would be well to remember that Hamma, in Algiers, lies near the latitude 36°, which corresponds with Raleigh, N. C., Nashville, Tennessee, and Fayetteville, Arkansas. Inasmuch as in Algiers the sorgho gives the largest yield of all its products, it follows that its culture in the United States will probably be found most remunerative in the territory lying between 40° and 29°, bounded on either side by Baltimore and New Orleans.—TRANS.

HISTORY OF THE SORGHO IN THE SOUTHERN STATES.

BY D. REDMOND,

Associate Editor of the "Southern Cultivator."

[The following valuable communication from D. Redmond, Esq., was not received in time for insertion in the body of this work, which accounts for its appearing in the Appendix.]

In the winter of 1854-5, I obtained, per mail, through a seed importing house in Boston, two ounces of what was then denominated "Chinese Sugar Cane, or *Holcus saccharatus*." I am not aware that any of this seed had been distributed from the Patent Office in this neighborhood, up to that time; nor had I then any other evidence of its value than the newspaper advertisement which induced me to send for it. I have since learned, however, that the Patent Office distributed a small quantity of seed in the spring of 1854; and that, prior even to that time, the plant had been tested to a limited extent by a few gentlemen in the vicinity of New Orleans. Nothing satisfactory, however, was known of the plant here at that time; and wishing to have it thoroughly tested, I sent small samples, per letter, to various agricultural and horticultural friends in Georgia, and the adjoining states, requesting them to communicate to me the result of their experiments with it. For myself, I merely planted seven or eight hills, in rather poor ground, in my garden, and watched its growth with considerable interest. At first I was disappointed, and quite ready to rank it among the many humbugs of the day, as it came up very weakly, like grass or Egyptian millet, and grew off quite slowly. In a few weeks, however, it began to shoot upward with great rapidity, and in less than three months attained the height of ten feet, with large and well-filled heads of seed. When these seeds were nearly ripe, I incidentally cut one of the stalks, peeled off the hard outer husk, and was quite surprised to find a solid pith or core, of about three fourths of an inch in diameter, crisp, brittle, and

of an exceedingly sweet and pleasant flavor—entirely unlike any thing of the corn stalk family that I had ever tasted. It was, in fact, *ready made candy*; and as soon as the younger members of the family and the negroes “got the taste” of it, I was obliged to interdict its further use, in order to save seed. When the latter were fully ripe, I cut off the heads and saved them carefully, noticing, with some surprise, that the leaves or blades of fodder were still as fresh, green, and succulent as ever. The stalks were then cut off near the ground, and fed, leaves and all, to my horses, mules, and milch cows; all of which ate of it with the greatest apparent relish and avidity. Considering that crop disposed of for the season, I paid no more attention to the stubble or stumps, until I happened to notice that, millet-like, they were shooting out anew, and pushing on for a second growth. This growth I watched with some interest, until the first frosts checked it; at which time the stalks were six feet high, full of broad and juicy leaves, and with the second crop of seed just making its appearance above the “boot.”

Convinced by this time that it was valuable at least for the production of soiling forage and dried fodder, I next turned my attention to its saccharine properties, and fortunately induced my friend, Dr. Robt. Battey, of Rome, Ga., who was at that time pursuing the study of experimental chemistry in the well-known laboratory of Prof. Booth, of Philadelphia, to test it. As the result of his experiments, Dr. Battey sent me three small phials—one containing a fine syrup; one a sample of crude, brown sugar; and the other a very good sample of crystallized sugar. This, I believe, to be the first crystallized sugar made in the United States, from the juice of the sorgho *sucré*; and, as Dr. Batty's opinion of its value as a sugar plant, fully agreed with the reports of the French *savans*, who had investigated its properties, and with my own convictions, I disseminated the seed more widely during the year 1856, and planted nearly two acres, for the purpose of raising the seed largely, and more fully testing the saccharine property and the ability of the plant to bear repeated cuttings, like the Egyptian and other varieties of millet. It was planted very late, on thin land, and received but imperfect culture, and yet, I that year cut it *three times*, and saved a late crop of fodder from it in addition. The

present year (1857) I have cut it *four times*, up to the present date, August 26.

During the summer of 1856, particular attention was called to the syrup making properties of this plant, by the Report of Governor Hammond, of South Carolina, whose experiments had been most ably and carefully conducted.

This Report was read before the "Beach Island (S. C.) Farmers' Club," and was followed by that of Colonel Peters, of Atlanta, and others, all of which were published, and presented such satisfactory results that the agricultural community generally were aroused to the importance of the new "Sugar Cane," and desirous of giving it a trial. The largest growers of the plant, at this time (1856) were, Absalom Jackson, Esq., of Montgomery, Ala.; Colonel R. Peters, of Atlanta; Dr. Whitten, of Hancock Co.; Dr. Daniell, of Decatur, Ga., and the writer. The seed raised by these persons was, we believe, nearly all saved, and very widely disseminated over the Union, but principally through the southern states, where, unquestionably, the plant attains its fullest and most perfect development. Twenty or thirty thousand packages of the seed alluded to were scattered over the country; and, in the South alone, probably thousands of acres are now growing. A large number of the growers are preparing to convert the juice of the sorgho into syrup and sugar; and if an easy and economical process for crystallizing the latter can be employed, this plant will at once become one of our most important staple productions. I have, within the past two months, received letters from gentlemen in nearly every one of the southern states, who were raising the cane from seed which I furnished, and the terms of praise, and even enthusiasm, with which they dwell upon its good qualities, are truly gratifying to me. Upon the whole, therefore, the sorgho may be considered a decided success, in the South, and the results obtained may be briefly summed up as follows:

1. An acre of the stalks, properly cultivated, on fair land, will yield from three hundred to six hundred gallons of excellent syrup, equal to the best New Orleans, and worth, at present prices, from forty-five to seventy cents per gallon.

2. If planted early, it will fully ripen *two crops* of seed, and two

crops of cane for crushing—as new shoots are invariably thrown out, from the roots, and attain full development after the first cutting, which takes place about the 25th of July, in this latitude, in favorable seasons.

3. From 25 to 100 bushels of seed can be raised to the acre, which seed, for all feeding purposes, is at least as valuable as oats.

4. It bears repeated cutting when green, and is inferior to no other plant for “soiling.”

5. The seed and fodder are fully equal in value to an ordinary corn crop, thus leaving the canes and their juice a clear profit to the cultivator.

6. It withstands our long droughts much better than common corn, retaining its green color and succulence even after the seed matures.

The various economical uses to which the sorgho may be applied, are so fully adverted to in other portions of this work, that it is unnecessary to enter farther into detail ; and I will close by expressing the conviction that, wherever the climate is suitable to its proper development, this plant will fully realize all its most sanguine friends have ever claimed for it.

D. REDMOND.

Augusta, Ga., August 26, 1857.

EXTRACT FROM THE EXPERIMENTS OF L'ECOLE
IMPERIALE DES PONTS ET CHAUSSEES.

*Specimens of the Stalks, Seeds, and Products of the Sugar Sorgho sent
by M. Raoulx.*

ANALYSIS OF SOIL ON WHICH THE PLANTS WERE GROWN.

Hygrometric water, lost at 130°	-	-	-	-	3.220
Water of combination, organic matters, and carbonic acid					10.320
Nitrogen	-	-	-	-	0.201
Silica and clay, insoluble in chlorohydric acid					74.900
Alumina	-	-	-	-	3.250
Peroxide of iron	-	-	-	-	0.320

2d. Matters soluble in Weak Azotic Acid.

Alumina and peroxide of iron	-	-	-	0.132
Lime	-	-	-	0.209
Magnesia	-	-	-	0.099
Alkalies	-	-	-	0.102
Phosphoric acid	-	-	-	0.107

1st. Matters insoluble in Water or Nitric Acid.

Silica and a little clay	-	-	-	0.493
Carbonic acid and loss	-	-	-	0.086
				<hr/>
				100.000
				<hr/>
				100.000

3d. ACID OF THE SORGHO.

Hygrometric water lost at 130°	-	-	-	14.850
Organic matters and water of combination; not including nitrogen	-	-	-	79.298
Nitrogen	-	-	-	2.052
Ashes	-	-	-	3.800
				<hr/>
				100.000

By a treatment with ether, the seed was found to yield 3.13 per cent. of oil.

Signed,

HERVÉ MANGON.

Countersigned,

CAVALIER.

All the Books on this Catalogue sent by mail, to any part of the Union, free of postage, upon receipt of Price.

CATALOGUE OF BOOKS
ON
AGRICULTURE AND HORTICULTURE,

PUBLISHED BY

A. O. MOORE,

(LATE C. M. SAXTON & COMPANY,)

No. 140 FULTON STREET, NEW YORK,

SUITABLE FOR

SCHOOL, TOWN, AGRICULTURAL, AND PRIVATE LIBRARIES.

THE AMERICAN FARMER'S ENCYCLOPEDIA, - - - \$2 00

EMBRACING ALL THE RECENT DISCOVERIES IN AGRICULTURAL CHEMISTRY, and the use of Mineral, Vegetable and Animal Manures, with Descriptions and Figures of American Insects injurious to Vegetation. Being a Complete Guide for the cultivation of every variety of Garden and Field Crops. Illustrated by numerous Engravings of Grasses, Grains, Animals, Implements, Insects, &c. By GOUVENEUR EMBEYSON, of Pennsylvania, upon the basis of Johnson's Farmer's Encyclopedia.

DOWNING'S (A. J.) LANDSCAPE GARDENING, - - - 3 50

A TREATISE ON THE THEORY AND PRACTICE OF LANDSCAPE GARDENING. Adapted to North America, with a view to the Improvement of Country Residences; comprising Historical Notices and General Principles of the Art, directions for Laying out Grounds and Arranging Plantations, the Description and Cultivation of Hardy Trees, Decorative Accompaniments to the House and Grounds, the Formation of Pieces of Artificial Waters, Flower Gardens, &c., with Remarks on Rural Architecture. Elegantly Illustrated, with a Portrait of the Author. By A. J. DOWNING.

DOWNING'S (A. J.) RURAL ESSAYS, - - - 3 00

ON HORTICULTURE, LANDSCAPE GARDENING, RURAL ARCHITECTURE, Trees, Agriculture, Fruit, with his Letters from England. Edited, with a Memoir of the Author, by GEORGE WM. CURTIS, and a letter to his friends, by FREDERICKA BREMER, and an elegant steel Portrait of the Author.

DADD'S ANATOMY AND PHYSIOLOGY OF THE HORSE, Plain, 2 00

Do. Do. Do. Colored Plates, 4 00

WITH ANATOMICAL AND QUESTIONAL ILLUSTRATIONS; Containing, also, a Series of Examinations on Equine Anatomy and Philosophy, with Instructions in reference to Dissection, and the mode of making Anatomical Preparations; to which is added a Glossary of Veterinary Technicalities, Toxicological Chart, and Dictionary of Veterinary Sciences.

DADD'S MODERN HORSE DOCTOR, - - - 1 00

CONTAINING PRACTICAL OBSERVATIONS ON THE CAUSES, NATURE and Treatment of Disease and Lameness of Horses, embracing the most recent and approved methods, according to an enlightened system of veterinary therapeutics, for the preservation and restoration of health. With Illustrations.

- DADD'S (GEO. H.) AMERICAN CATTLE DOCTOR,** - - - \$1 00
 CONTAINING THE NECESSARY INFORMATION FOR PRESERVING THE Health and Curing the Diseases of Oxen, Cows, Sheep, and Swine, with a great variety of Original Recipes and Valuable Information in reference to Farm and Dairy management, whereby every man can be his own Cattle Doctor. The principles taught in this work are, that all Medication shall be subservient to Nature—that all Medicines must be sensitive in their operation, and administered with a view of aiding the vital powers, instead of depressing, as heretofore, with the lancet or by poison. By G. H. DADD, M. D., Veterinary Practitioner.
- THE DOG AND GUN,** - - - - - 50
 A FEW LOOSE CHAPTERS ON SHOOTING, among which will be found some Anecdotes and Incidents; also, instructions for Dog Breaking, and interesting letters from Sportsmen. By A BAD SHOT.
- MORGAN HORSES,** - - - - - 1 00
 A PREMIUM ESSAY ON THE ORIGIN, HISTORY, AND CHARACTERISTICS of this remarkable American Breed of Horses; tracing the Pedigree from the original Justin Morgan, through the most noted of his progeny, down to the present time. With numerous portraits. To which are added hints for Breeding, Breaking, and General Use and Management of Horses, with practical Directions for training them for exhibition at Agricultural Fairs. By D. C. LINSLEY.
- BORGHO AND IMPHEE, THE CHINESE AND AFRICAN SUGAR CANES,** - - - - - 1 00
 A COMPLETE TREATISE UPON THEIR ORIGIN AND VARIETIES, CULTURE and Uses, their value as a Forage Crop, and directions for making Sugar, Molasses, Alcohol, Sparkling and Still Wines, Beer, Cider, Vinegar, Paper, Starch, and Dye Stuffs. Fully Illustrated with Drawings of Approved Machinery; With an Appendix by LEONARD WRAY, of Caffraria, and a description of his patented process of crystallizing the juice of the Imphee; with the latest American experiments, including those of 1857, in the South. By HENRY S. OLOORT. To which are added translations of valuable French Pamphlets, received from the Hon. JOHN Y. MASON, American Minister at Paris.
- THE STABLE BOOK,** - - - - - 1 00
 A TREATISE ON THE MANAGEMENT OF HORSES, IN RELATION TO Stabling, Grooming, Feeding, Watering and Working, Construction of Stables, Ventilation, Appendages of Stables, Management of the Feet, and of Diseased and Defective Horses. By JOHN STEWART, Veterinary Surgeon. With Notes and Additions, adapting it to American Food and Climate. By A. B. ALLEN, Editor of the American Agriculturist.
- THE HORSE'S FOOT, AND HOW TO KEEP IT SOUND,** - - - 50
 WITH CUTS, ILLUSTRATING THE ANATOMY OF THE FOOT, and containing valuable Hints on Shoeing and Stable Management, in Health and in Disease. By WILLIAM MILLS.
- THE FRUIT GARDEN,** - - - - - 1 25
 A TREATISE, INTENDED TO EXPLAIN AND ILLUSTRATE THE PHYSIOLOGY of Fruit Trees, the Theory and Practice of all Operations connected with the Propagation, Transplanting, Pruning and Training of Orchard and Garden Trees, as Standard, Dwarf, Pyramids, Espalier, &c. The Laying out and Arranging different kinds of Orchards and Gardens, the selection of suitable varieties for different purposes and localities, Gathering and Preserving Fruits, Treatment of Diseases, Destruction of Insects, Description and Uses of Implements, &c. Illustrated with upwards of 150 Figures, representing Different Parts of Trees, all Practical Operations, forms of Trees, Designs for Plantations, Implements, &c. By P. BARRY, of the Mount Hope Nurseries, Rochester, N. Y.
- FIELD'S PEAR CULTURE,** - - - - - 60
 THE PEAR GARDEN; OR, a Treatise on the Propagation and Cultivation of the Pear Tree, with Instructions for its Management from the Seedling to the Bearing Tree. By THOMAS W. FIELD.

- BUIST'S (EBOERT) FAMILY KITCHEN GARDENER, - - - \$0 75**
 CONTAINING PLAIN AND ACCURATE DESCRIPTIONS OF ALL THE DIFFERENT SPECIES AND VARIETIES OF CULINARY VEGETABLES, WITH THEIR BOTANICAL, ENGLISH, FRENCH AND GERMAN NAMES, ALPHABETICALLY ARRANGED, WITH THE BEST MODE OF CULTIVATING THEM IN THE GARDEN OR UNDER GLASS; ALSO DESCRIPTIONS AND CHARACTER OF THE MOST SELECT FRUITS, THEIR MANAGEMENT, PROPAGATION, &c. By ROBERT BUIST, author of the "American Flower Garden Directory," &c.
- DOMESTIC AND ORNAMENTAL POULTRY, Plain Plates, - - - 1 00**
 Do. Do. Do. Colored Plates, - - - 2 00
 A TREATISE ON THE HISTORY AND MANAGEMENT OF ORNAMENTAL AND DOMESTIC POULTRY. By Rev. EDMUND SAUL DIXON, A.M., with large additions by J. J. KEAR, M.D. Illustrated with sixty-five Original Portraits, engraved expressly for this work. Fourth edition revised.
- HOW TO BUILD AND VENTILATE HOT-HOUSES, - - - 1 25**
 A PRACTICAL TREATISE ON THE CONSTRUCTION, HEATING AND VENTILATION OF HOT-HOUSES, INCLUDING CONSERVATORIES, GREEN-HOUSES, GRAPERIES AND OTHER KINDS OF HORTICULTURAL STRUCTURES, WITH PRACTICAL DIRECTIONS FOR THEIR MANAGEMENT, IN REGARD TO LIGHT, HEAT AND AIR. Illustrated with numerous engravings. By P. B. LEUCHEM, Garden Architect.
- CHORLTON'S GRAPE-GROWER'S GUIDE, - - - - - 60**
 INTENDED ESPECIALLY FOR THE AMERICAN CLIMATE. Being a Practical Treatise on the Cultivation of the Grape Vine in each department of Hot-House, Cold Grapery, Retarding House and Out-door Culture. With Plans for the Construction of the Requisite Buildings, and giving the best methods for Heating the same. Every department being fully illustrated. By WILLIAM CHORLTON.
- NORTON'S (JOHN P.) ELEMENTS OF SCIENTIFIC AGRICULTURE, 60**
 OR, THE CONNECTION BETWEEN SCIENCE AND THE ART OF PRACTICAL FARMING. Prize Essay of the New York State Agricultural Society. By JOHN P. NORTON, M.A., Professor of Scientific Agriculture in Yale College. Adapted to the use of Schools.
- JOHNSTON'S (J. F. W.) CATECHISM OF AGRICULTURAL CHEMISTRY AND GEOLOGY, - - - - - 25**
 BY JAMES F. W. JOHNSTON, M.A., F.R.S.S.L. and E., Honorary Member of the Royal Agricultural Society of England, and author of "Lectures on Agricultural Chemistry and Geology." With an Introduction by JOHN PITKIN NORTON, M.A., late Professor of Scientific Agriculture in Yale College. With notes and additions by the author, prepared expressly for this edition, and an Appendix compiled by the Superintendent of Education in Nova Scotia. Adapted to the use of Schools.
- JOHNSTON'S (J. F. W.) ELEMENTS OF AGRICULTURAL CHEMISTRY AND GEOLOGY, - - - - - 1 00**
 With a Complete Analytical and Alphabetical Index and an American Preface. By Hon. SIMON BROWN, Editor of the "New England Farmer."
- JOHNSTON'S (JAMES F. W.) AGRICULTURAL CHEMISTRY, 1 25**
 LECTURES ON THE APPLICATION OF CHEMISTRY AND GEOLOGY TO AGRICULTURE. New edition, with an Appendix, containing the Author's Experiments in Practical Agriculture.
- THE COMPLETE FARMER AND AMERICAN GARDENER, 1 25**
 RURAL ECONOMIST AND NEW AMERICAN GARDENER; Containing a Compendious Epitome of the most Important Branches of Agriculture and Rural Economy; with Practical Directions on the Cultivation of Fruits and Vegetables, including Landscape and Ornamental Gardening. By THOMAS G. FESSENDEN. 2 vols. in one.
- FESSENDEN'S (T. G.) AMERICAN KITCHEN GARDENER, - 50**
 CONTAINING DIRECTIONS FOR THE CULTIVATION OF VEGETABLES AND GARDEN FRUITS. Cloth.

NASH'S (J. A.) PROGRESSIVE FARMER,	- - - -	\$0 60
A SCIENTIFIC TREATISE ON AGRICULTURAL CHEMISTRY, THE Geology of Agriculture, on Plants and Animals, Manures and Soils, applied to Practical Agriculture; with a Catechism of Scientific and Practical Agriculture. By J. A. NASH.		
BRECK'S BOOK OF FLOWERS,	- - - -	1 00
IN WHICH ARE DESCRIBED ALL THE VARIOUS HARDY HERBACEOUS Perennials, Annuals, Shrubs, Plants and Evergreen Trees, with Directions for their Cultivation.		
SMITH'S (C. H. J.) LANDSCAPE GARDENING, PARKS AND PLEASURE		
 GROUNDS,	- - - -	1 25
WITH PRACTICAL NOTES ON COUNTRY RESIDENCES, VILLAS, PUBLIC Parks and Gardens. By CHARLES H. J. SMITH, Landscape Gardener and Garden Architect, &c. With Notes and Additions by LEWIS F. ALLEN, author of "Rural Architecture."		
THE COTTON PLANTER'S MANUAL,	- - - -	1 00
BEING A COMPILATION OF FACTS FROM THE BEST AUTHORITIES on the Culture of Cotton, its Natural History, Chemical Analysis, Trade and Consumption, and embracing a History of Cotton and the Cotton Gin. By J. A. TURNER.		
COBBETT'S AMERICAN GARDENER,	- - - -	50
A TREATISE ON THE SITUATION, SOIL, AND LAYING-OUT OF GARDENS, and the making and managing of Hot-Beds and Green-Houses, and on the Propagation and Cultivation of the several sorts of Vegetables, Herbs, Fruits and Flowers.		
ALLEN (J. FISK) ON THE CULTURE OF THE GRAPE,	- - - -	1 00
A PRACTICAL TREATISE ON THE CULTURE AND TREATMENT OF THE Grape Vine, embracing its History, with Directions for its Treatment in the United States of America, in the Open Air and under Glass Structures, with and without Artificial Heat. By J. FISK ALLEN.		
ALLEN'S (R. L.) DISEASES OF DOMESTIC ANIMALS,	- - - -	75
BEING A HISTORY AND DESCRIPTION OF THE HORSE, MULE, CATTLE, Sheep, Swine, Poultry, and Farm Dogs, with Directions for their Management, Breeding, Crossing, Bearing, Feeding, and Preparation for a Profitable Market; also, their Diseases and Remedies, together with full Directions for the Management of the Dairy, and the comparative Economy and Advantages of Working Animals, the Horse, Mule, Oxen, &c. By R. L. ALLEN.		
ALLEN'S (R. L.) AMERICAN FARM BOOK,	- - - -	1 00
THE AMERICAN FARM BOOK; or, a Compend of American Agriculture, being a Practical Treatise on Soils, Manures, Draining, Irrigation, Grasses, Grain, Roots, Fruits, Cotton, Tobacco, Sugar Cane, Rice, and every Staple Product of the United States; with the Best Methods of Planting, Cultivating and Preparation for Market. Illustrated with more than 100 engravings. By R. L. ALLEN.		
ALLEN'S (L. F.) RURAL ARCHITECTURE;	- - - -	1 25
BEING A COMPLETE DESCRIPTION OF FARM HOUSES, COTTAGES, AND Out Buildings, comprising Wood Houses, Workshops, Tool Houses, Carriage and Wagon Houses, Stables, Smoke and Ash Houses, Ice Houses, Apiaries or Bee Houses, Poultry Houses, Rabbltry, Dovecote, Piggery, Barns, and Sheds for Cattle, &c., &c., together with Lawns, Pleasure Grounds, and Parks; the Flower, Fruit, and Vegetable Garden; also useful and ornamental domestic Animals for the Country Resident, &c., &c. Also, the best method of conducting water into Cattle Yards and Houses. Beautifully illustrated.		
WARING'S ELEMENTS OF AGRICULTURE;	- - - -	75
A BOOK FOR YOUNG FARMERS, WITH QUESTIONS FOR THE USE OF Schools.		

- PARDEE (R. G.) ON STRAWBERRY CULTURE;** - - - \$0 60
 A COMPLETE MANUAL FOR THE CULTIVATION OF THE STRAWBERRY;
 with a description of the best varieties.
 Also, notices of the Raspberry, Blackberry, Currant, Gooseberry, and Grape; with
 directions for their cultivation, and the selection of the best varieties. "Every process
 here recommended has been proved, the plans of others tried, and the result is here
 given." With a valuable appendix, containing the observations and experience of
 some of the most successful cultivators of these fruits in our country.
- GUENON ON MILCH COWS;** - - - - - 60
 A TREATISE ON MILCH COWS, whereby the Quality and Quantity of
 Milk which any Cow will give may be accurately determined by observing Natural
 Marks or External Indications alone; the length of time she will continue to give
 Milk, &c., &c. By M. FRANCOIS GUENON, of Libourne, France. Translated by NICHOLAS
 P. TRIST, Esq.; with Introduction, Remarks, and Observations on the Cow and
 the Dairy, by JOHN B. SKINNER. Illustrated with numerous engravings. Neatly
 done up in paper covers, 37 cts.
- AMERICAN POULTRY YARD;** - - - - - 1 00
 COMPRISING THE ORIGIN, HISTORY AND DESCRIPTION of the different
 Breeds of Domestic Poultry, with complete directions for their Breeding, Crossing,
 Rearing, Fattening, and Preparation for Market; including specific directions for
 Caponizing Fowls, and for the Treatment of the Principal Diseases to which they are
 subject, drawn from authentic sources and personal observation. Illustrated with
 numerous engravings. By D. J. BROWN.
- BROWNE'S (D. JAY) FIELD BOOK OF MANURES;** - - - 1 25
 OR, AMERICAN MUCK BOOK; Treating of the Nature, Properties,
 Sources, History, and Operations of all the Principal Fertilizers and Manures in Com-
 mon Use, with specific directions for their Preservation, and Application to the Soil
 and to Crops; drawn from authentic sources, actual experience, and personal observa-
 tion, as combined with the Leading Principles of Practical and Scientific Agriculture.
 By D. JAY BROWNE.
- RANDALL'S (H. S.) SHEEP HUSBANDRY;** - - - 1 25
 WITH AN ACCOUNT OF THE DIFFERENT BREEDS, and general direc-
 tions in regard to Summer and Winter Management, Breeding, and the Treatment of
 Diseases, with Portraits and other Engravings. By HENRY S. RANDALL.
- THE SHEPHERD'S OWN BOOK;** - - - - - 2 00
 WITH AN ACCOUNT OF THE DIFFERENT BREEDS, DISEASES AND MAN-
 agement of Sheep, and General Directions in regard to Summer and Winter Man-
 agement, Breeding, and the Treatment of Diseases; with Illustrative Engravings, by
 YOUATT & RANDALL; embracing Skinner's Notes on the Breed and Management of
 Sheep in the United States, and on the Culture of Fine Wool.
- YOUATT ON SHEEP;** - - - - - 75
 THEIR BREED, MANAGEMENT AND DISEASES, with Illustrative En-
 gravings; to which are added Remarks on the Breeds and Management of Sheep in
 the United States, and on the Culture of Fine Wool in Silesia. By WILLIAM YOUATT.
- YOUATT AND MARTIN ON CATTLE;** - - - - - 1 25
 BEING A TREATISE ON THEIR BREEDS, MANAGEMENT, AND DISEASES,
 comprising a full History of the Various Races; their Origin, Breeding, and Merits;
 their capacity for Beef and Milk. By W. YOUATT and W. C. L. MARTIN. The whole
 forming a Complete Guide for the Farmer, the Amateur, and the Veterinary Surgeon,
 with 100 Illustrations. Edited by AMBROSE STEVENS.
- YOUATT ON THE HORSE;** - - - - - 1 25
 YOUATT ON THE STRUCTURE AND DISEASES OF THE HORSE, with
 their Remedies. Also, Practical Rules for Buyers, Breeders, Smiths, &c. Edited by
 W. C. SPOONER, M.R.C.V.S. With an account of the Breeds in the United States, by
 HENRY S. RANDALL.

- YOUATT AND MARTIN ON THE HOG;** - - - - - **\$0 75**
 A TREATISE ON THE BREEDS, MANAGEMENT, AND MEDICAL TREATMENT of Swine, with Directions for Salting Pork, and Curing Bacon and Hams. By WM. YOUATT, V.S., and W. C. L. MARTIN. Edited by AMBROSE STEVENS. Illustrated with Engravings drawn from life.
- BLAKE'S (REV. JOHN L.) FARMER AT HOME;** - - - - - **1 25**
 A FAMILY TEXT BOOK FOR THE COUNTRY; being a Cyclopaedia of Agricultural Implements and Productions, and of the more important topics in Domestic Economy, Science, and Literature, adapted to Rural Life. By Rev. JOHN L. BLAKE, D. D.
- MUNN'S (B.) PRACTICAL LAND DRAINER;** - - - - - **50**
 BEING A TREATISE ON DRAINING LAND, in which the most approved systems of Drainage are explained, and their differences and comparative merits discussed; with full Directions for the Cutting and Making of Drains, with Remarks upon the various materials of which they may be constructed. With many illustrations. By B. MUNN, Landscape Gardener.
- ELLIOTT'S AMERICAN FRUIT GROWER'S GUIDE IN ORCHARD AND GARDEN;** - - - - - **1 25**
 BEING A COMPEND OF THE HISTORY, MODES OF PROPAGATION, CULTURE, &c., of Fruit Trees and Shrubs, with descriptions of nearly all the varieties of fruits cultivated in this country; and Notes of their adaptation to localities, soils, and a complete list of fruits worthy of cultivation. By P. E. ELLIOTT, Pomologist.
- PRACTICAL FRUIT, FLOWER, AND KITCHEN GARDENER'S COMPANION;** - - - - - **1 00**
 WITH A CALENDAR. By PATRICK NEILL, LL.D., F.R.S.E., Secretary of the Royal Caledonian Horticultural Society. Adapted to the United States from the fourth edition, revised and improved by the author. Edited by G. EMERSON, M. D., Editor of "The American Farmer's Encyclopedia." With Notes and Additions by E. G. PARDEE, author of "Manual of the Strawberry Culture." With illustrations.
- STEPHENS' (HENRY) BOOK OF THE FARM;** - - - - - **4 00**
 A COMPLETE GUIDE TO THE FARMER, STEWARD, PLOWMAN, CATTLEMAN, Shepherd, Field Worker, and Dairy Maid. By HENRY STEPHENS. With Four Hundred and Fifty Illustrations; to which are added Explanatory Notes, Remarks, &c., by J. S. SKINNER. Really one of the best books a farmer can possess.
- PEDDERS' (JAMES) FARMERS' LAND MEASURER;** - - - - - **50**
 OR, POCKET COMPANION; Showing at one view the Contents of any Piece of Land from Dimensions taken in Yards. With a set of Useful Agricultural Tables.
- WHITE'S (W. N.) GARDENING FOR THE SOUTH;** - - - - - **1 25**
 OR, THE KITCHEN AND FRUIT GARDEN, with the best methods for their Cultivation; together with hints upon Landscape and Flower Gardening; containing modes of culture and descriptions of the species and varieties of the Culinary Vegetables, Fruit Trees, and Fruits, and a select list of Ornamental Trees and Plants, found by trial adapted to the States of the Union south of Pennsylvania, with Gardening Calendars for the same. By WM. N. WHITE, of Athens, Georgia.
- EASTWOOD (B.) ON THE CULTIVATION OF THE CRANBERRY;** **50**
 WITH A DESCRIPTION OF THE BEST VARIETIES. By B. EASTWOOD, "Septimus" of the New York Tribune.
- AMERICAN BEE-KEEPER'S MANUAL;** - - - - - **1 00**
 BEING A PRACTICAL TREATISE ON THE HISTORY AND DOMESTIC ECONOMY of the Honey Bee, embracing a full illustration of the whole subject, with the most approved methods of managing this Insect, through every branch of its Culture; the result of many years' experience. Illustrated with many engravings. By T. B. MINER.

- THAER'S (ALBERT D.) AGRICULTURE** - - - \$3 00
 THE PRINCIPLES OF AGRICULTURE, by ALBERT D. THAER; translated by WILLIAM SHAW and CUTBERT W. JOHNSON, Esq., F.R.S. With a Memoir of the Author. 1 vol. 8vo.
 This work is regarded by those who are competent to judge as one of the most beautiful works that has ever appeared on the subject of Agriculture. At the same time that it is eminently practical, it is philosophical, and, even to the general reader, remarkably entertaining.
- BOUSSINGAULT'S (J. B.) RURAL ECONOMY,** - - - 1 25
 IN ITS RELATIONS TO CHEMISTRY, PHYSICS, AND METEOROLOGY; or, Chemistry applied to Agriculture. By J. B. BOUSSINGAULT. Translated, with notes, etc., by GEORGE LAW, Agriculturist.
 "The work is the fruit of a long life of study and experiment, and its perusal will aid the farmer greatly in obtaining a practical and scientific knowledge of his profession."
- MYSTERIES OF BEE-KEEPING EXPLAINED;** - - - 1 00
 BEING A COMPLETE ANALYSIS OF THE WHOLE SUBJECT, consisting of the Natural History of Bees; Directions for obtaining the greatest amount of Pure Surplus Honey with the least possible expense; Remedies for losses given, and the Science of Luck fully illustrated; the result of more than twenty years' experience in extensive Apiaries. By M. QUINBY.
- THE COTTAGE AND FARM BEE-KEEPER;** - - - 50
 A PRACTICAL WORK, by a Country Curate.
- WEEKS (JOHN M.) ON BEES.—A MANUAL;** - - - 50
 OR, AN EASY METHOD OF MANAGING BEES IN THE MOST PROFITABLE manner to their owner; with infallible rules to prevent their destruction by the Moth. With an appendix, by WOOSTER A. FLANDERS.
- THE ROSE;** - - - 50
 BEING A PRACTICAL TREATISE ON THE PROPAGATION, CULTIVATION, and Management of the Rose in all Seasons; with a list of Choice and Approved Varieties, adapted to the Climate of the United States; to which is added full directions for the Treatment of the Dahlia. Illustrated by Engravings.
- MOORE'S RURAL HAND BOOKS,** - - - 1 25
 FIRST SERIES, containing Treatises on—
 THE HORSE, THE PESTS OF THE FARM,
 THE HOG, DOMESTIC FOWLS, and
 THE HONEY BEE, THE COW,
 SECOND SERIES, containing— - - - 1 25
 EVERY LADY HER OWN FLOWER GARDENER, ESSAY ON MANURES,
 ELEMENTS OF AGRICULTURE, AMERICAN KITCHEN GARDENER,
 BIRD FANCIER, AMERICAN ROSE CULTURIST.
- THIRD SERIES, containing— - - - 1 25
 MILES ON THE HORSE'S FOOT, VINE DRESSER'S MANUAL,
 THE RABBIT FANCIER, BEE-KEEPER'S CHART,
 WEEKS ON BEES, CHEMISTRY MADE EASY.
- FOURTH SERIES, containing— - - - 1 25
 PRESSON ON THE VINE, HOOPER'S DOG AND GUN,
 LEBIG'S FAMILIAR LETTERS, SKILLFUL HOUSEWIFE,
 BROWN'S MEMOIRS OF INDIAN CORN.
- RICHARDSON ON DOGS: THEIR ORIGIN AND VARIETIES.** . . . 50
 DIRECTIONS AS TO THEIR GENERAL MANAGEMENT. With numerous original anecdotes. Also, Complete Instructions as to Treatment under Disease. By H. D. RICHARDSON. Illustrated with numerous wood engravings.
 This is not only a cheap work, but one of the best ever published on the Dog.

LIEBIG'S (JUSTUS) FAMILIAR LECTURES ON CHEMISTRY,	\$0 50
AND ITS RELATION TO COMMERCE, PHYSIOLOGY, AND AGRICULTURE.	
Edited by JOHN GARDNER, M.D.	
BEMENT'S (C. N.) RABBIT FANCIER;	50
A TREATISE ON THE BREEDING, REARING, FEEDING, AND GENERAL Management of Rabbits, with remarks upon their diseases and remedies, to which are added full directions for the construction of Hutches, Rabbitries, &c., together with recipes for cooking and dressing for the Table. Beautifully illustrated.	
THOMPSON (R. D.) ON THE FOOD OF ANIMALS	75
EXPERIMENTAL RESEARCHES ON THE FOOD OF ANIMALS AND THE Fattening of Cattle; with remarks on the Food of Man. Based upon Experiments undertaken by order of the British Government, by ROBERT DUNDAS THOMPSON, M.D., Lecturer on Practical Chemistry, University of Glasgow.	
THE WESTERN FRUIT BOOK;	1 25
BEING A COMPEND OF THE HISTORY, MODES OF PROPAGATION, CULTURE, &c., of Fruit Trees and Shrubs, &c., &c. By F. R. ELLIOTT.	
THE SKILLFUL HOUSEWIFE;	50
OR COMPLETE GUIDE TO DOMESTIC COOKERY, TASTE, COMFORT, AND Economy, embracing 689 recipes pertaining to Household Duties, the care of Health, Gardening, Birds, Education of Children, &c., &c. By Mrs L. G. ABELL.	
THE AMERICAN FLORIST'S GUIDE;	75
COMPRISING THE AMERICAN ROSE CULTURIST AND EVERY LADY HER own Flower Gardener.	
EVERY LADY HER OWN FLOWER GARDENER;	50
ADDRESSED TO THE INDUSTRIOUS AND ECONOMICAL ONLY; containing simple and practical Directions for Cultivating Plants and Flowers; also, Hints for the Management of Flowers in Rooms, with brief Botanical Descriptions of Plants and Flowers. The whole in plain and simple language. By LOUISA JOHNSON.	

M O O R E ' S

Hand Books of Rural and Domestic Economy.

All arranged and adapted to the Use of American Farmers.

PRICE 25 CENTS EACH.

HOGS;

THEIR ORIGIN, VARIETIES AND MANAGEMENT, with a View to Profit, and Treatment under Disease; also Plain Directions relative to the most approved modes of preserving their Flesh. By H. D. RICHARDSON, author of "The Hive and the Honey Bee," &c., &c. With illustrations—12mo.

THE HIVE AND THE HONEY BEE;

WITH PLAIN DIRECTIONS FOR OBTAINING A CONSIDERABLE ANNUAL Income from this branch of Rural Economy; also an Account of the Diseases of Bees and their Remedies, and Remarks as to their Enemies, and the best mode of protecting the Hives from their attacks. By H. D. RICHARDSON. With illustrations.

DOMESTIC FOWLS;

THEIR NATURAL HISTORY, BREEDING, REARING, AND GENERAL Management. By H. D. RICHARDSON, author of "The Natural History of the Fossil Deer," &c. With illustrations.

THE HORSE;

THEIR ORIGIN AND VARIETIES; WITH PLAIN DIRECTIONS AS TO THE Breeding, Rearing, and General Management, with Instructions as to the Treatment of Disease. Handsomely illustrated—12mo. By H. D. RICHARDSON.

THE ROSE;

THE AMERICAN ROSE CULTURIST; being a Practical Treatise on the Propagation, Cultivation, and Management in all Seasons, &c. With full directions for the Treatment of the Dahlia.

THE PESTS OF THE FARM;

WITH INSTRUCTIONS FOR THEIR EXTIRPATION; being a Manual of Plain Directions for the certain Destruction of every description of Vermin. With numerous illustrations on Wood.

AN ESSAY ON MANURES;

SUBMITTED TO THE TRUSTEES OF THE MASSACHUSETTS SOCIETY FOR Promoting Agriculture, for their Premium. By SAMUEL H. DANA.

THE AMERICAN BIRD FANCIER;

CONSIDERED WITH REFERENCE TO THE BREEDING, REARING, FEED- ing, Management, and Peculiarities of Cage and House Birds. Illustrated with Engravings. By D. JAY BROWN.

CHEMISTRY MADE EASY;

FOR THE USE OF FARMERS. By J. TOPHAM.

ELEMENTS OF AGRICULTURE;

TRANSLATED FROM THE FRENCH, and Adapted to the use of American Farmers. By F. G. SKINNER.

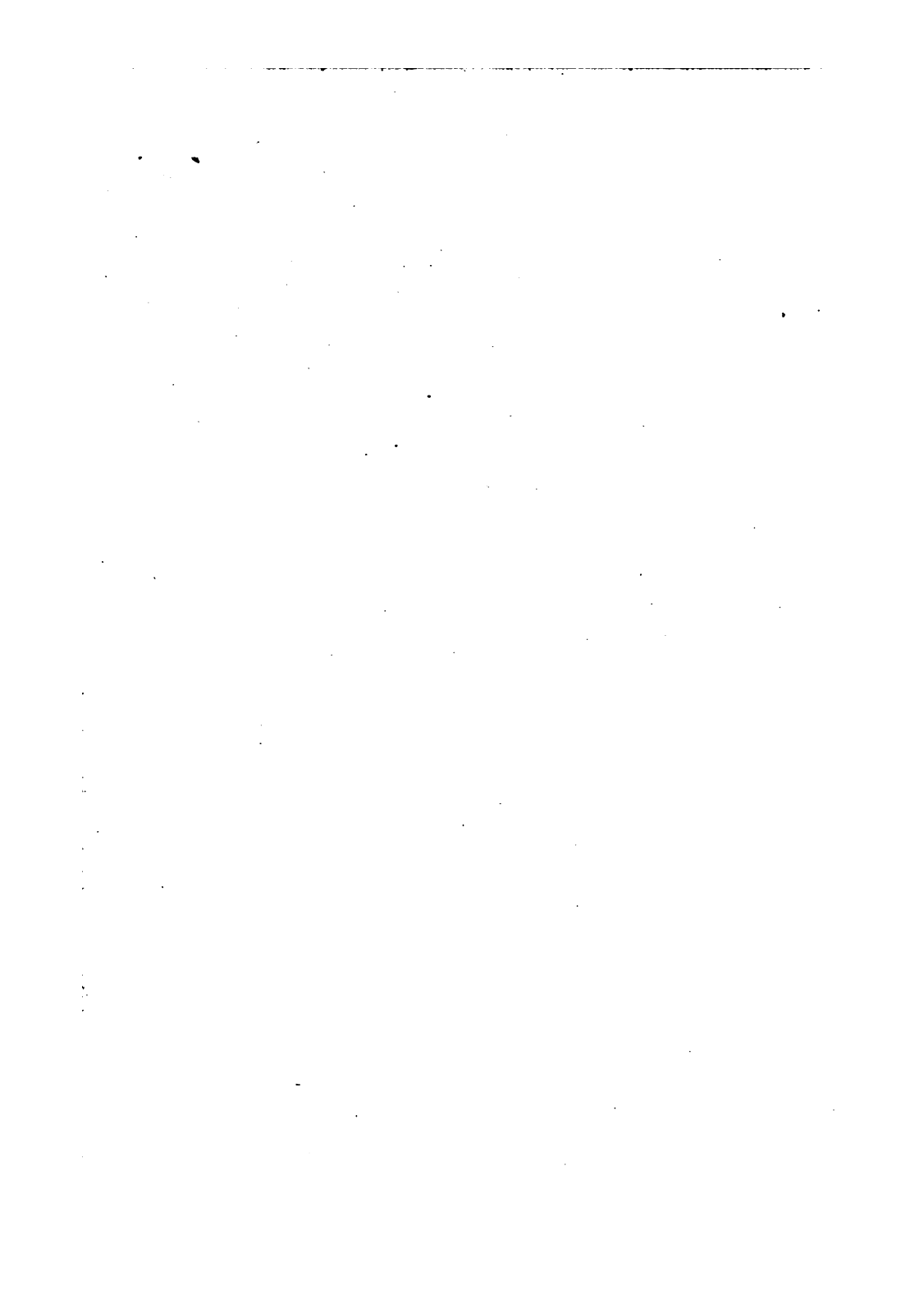

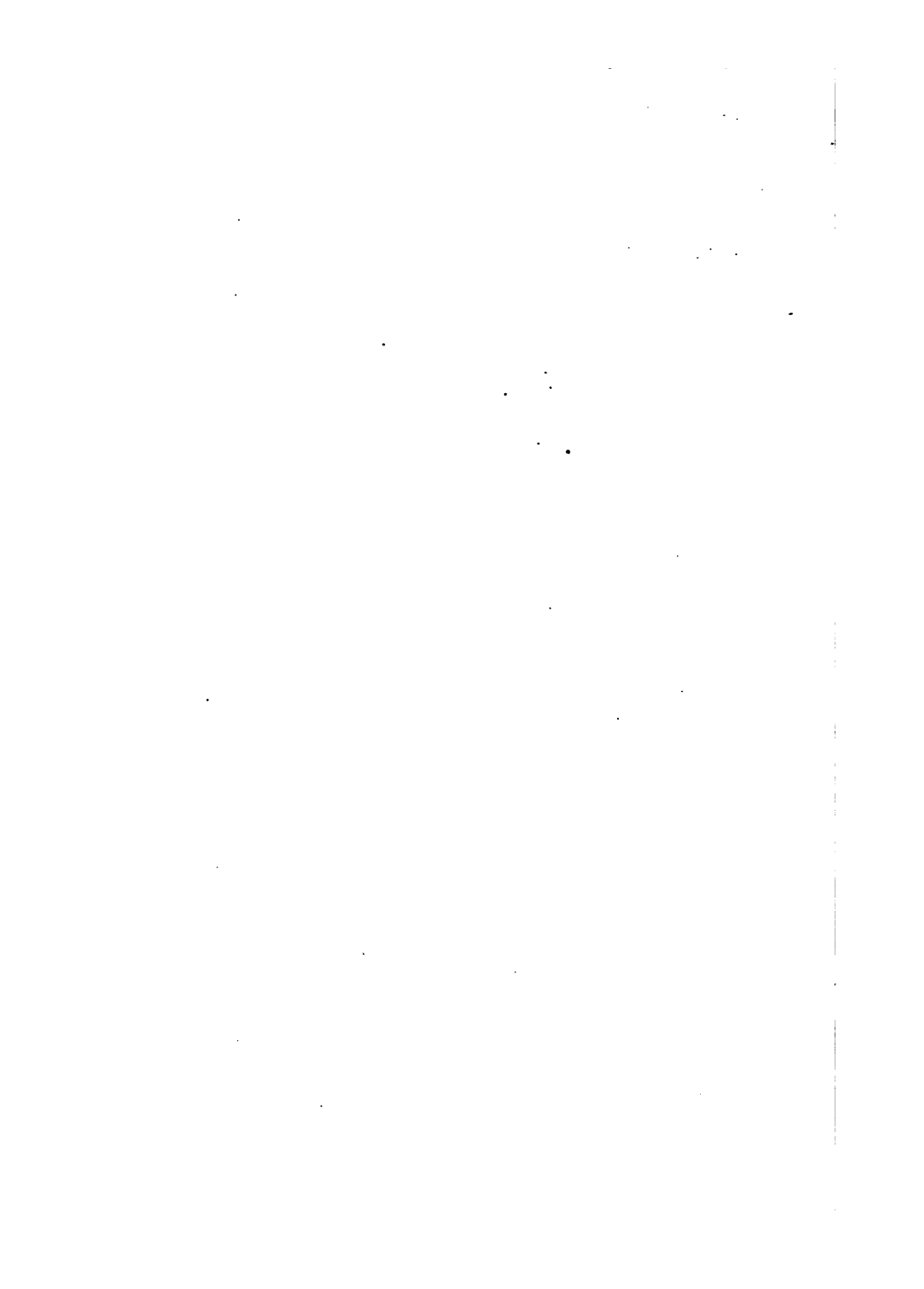

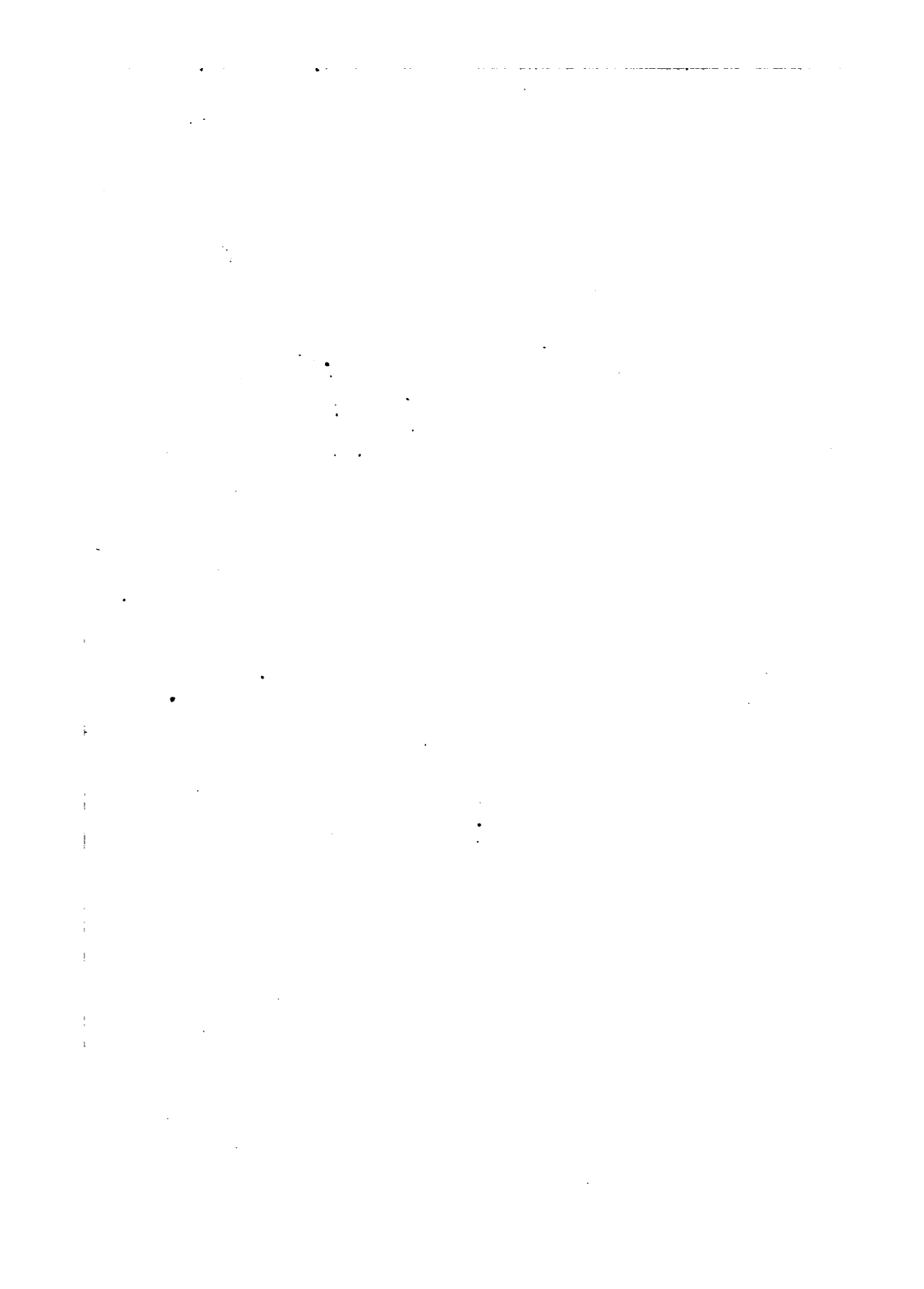



The following text is extremely faint and illegible due to the low contrast and blurriness of the scan. It appears to be a list or a series of entries, but the specific content cannot be discerned.

NOV 26 1881

MAR

55 H

STUDY
CHARGE
CANCELLED

~~MAR~~

~~6 55 H~~

~~MAR 20 '56 H~~

~~MAY 8 '56 H~~

